

**READ AND SAVE THESE INSTRUCTIONS**

**HUMIDIFIRST**

***HUMIDIFIRST***

**ULTRASONIC HUMIDIFIERS**

**OWNER'S MANUAL**

**FOR**

**MIST-PAC SERIES**

**ULTRASONIC HUMIDIFIERS**

5-1-12

## **TABLE OF CONTENTS**

	<b><u>Page</u></b>
<b>Introduction</b>	<b>3</b>
<b>Understanding humidification</b>	<b>3</b>
<b>Principles of ultrasonic humidification</b>	<b>4</b>
<b>Calculating your humidification load</b>	<b>5</b>
<b>Physical dimensions of the humidifier modules</b>	<b>6, 7</b>
<b>Master panel dimensions and layout</b>	<b>8</b>
<b>Specification of the humidifier and controls</b>	<b>9</b>
<b>Positioning your humidifier module and Master Panel</b>	<b>10</b>
<b>Installation requirements</b>	<b>10</b>
<b>Installation Parameters &amp; Guidelines</b>	<b>11</b>
<b>Before you start your humidifier for the first time</b>	<b>12</b>
<b>Starting your humidifier for the first time</b>	<b>13</b>
<b>Ultra-Pulse module instruction</b>	<b>14</b>
<b>Trouble shooting at start-up time</b>	<b>15, 16, 17</b>
<b>Trouble shooting after start-up</b>	<b>18</b>
<b>Recommended Maintenance</b>	
<b>a. Basic maintenance</b>	<b>19</b>
<b>b. Transducer maintenance</b>	<b>19</b>
<b>c. End of humidifier season shutdown</b>	<b>20</b>
<b>d. Humidistat cleaning</b>	<b>20</b>
<b>Warranty</b>	<b>20</b>
<b>Manual Disclaimer</b>	<b>20</b>
<b>Start-up form</b>	<b>21, 22, 23</b>

## **INTRODUCTION**

Congratulations on your purchase of a HUMIDIFIRST Mist-Pac ultrasonic humidifier – the highest quality and most “User Friendly” commercial/industrial humidifier available today. Your selection of an ultrasonic humidifier provides you with the benefits of this technology, including **energy efficiency, minimal maintenance, and healthy, uncontaminated moisture.** And HUMIDIFIRST humidifiers are 100% American made.

HUMIDIFIRST humidifiers are made of ABS plastic or high grade stainless steel. This ensures unit longevity, minimal maintenance, and a clean, healthy humidifier.

## **UNDERSTANDING HUMIDIFICATION**

Maintaining a specific relative humidity level in a building or a room is not an exact science. Quality of construction, vapor barrier, air infiltration, and air exhaust all play a role in the ability of a humidifier to maintain the relative humidity of a space. Also, some older buildings may form ice in colder temperatures on the outside walls due to humidified air seeping through cracks. Windows, too, may ice up when the outside temperature drops. The type of window (e.g. single pane, double pane) can affect the amount of window icing or sweating.

The level of relative humidity at which you maintain the space will also affect the amount of window icing or sweating. For example, a building may have moisture problems at 50% RH but not at 30% RH.

Also, bear in mind that relative humidity may fluctuate in a given space. If you walk around a large room with a hand held relative humidity meter, you may find variations in relative humidity. This is typically due to variations in space temperature. Relative humidity is “relative” to temperature, and hence changes in space temperature will affect the relative humidity of the air.

## **PRINCIPLES OF ULTRASONIC HUMIDIFIERS**

Ultrasonic humidifiers vibrate a water mist into the air by using piezoelectric crystals (transducers). The transducers are mounted in a basin of water approximately 1.5 inches deep. Each transducer is approximately the size of a nickel and vibrates at approximately 1.6 megahertz, a speed so fast that the water above the crystal cannot follow the speed of the transducer, causing the water to cavitate. This process emits very small water droplets into the air, approximately one micron in diameter (similar in size to steam droplets). The water droplets are so small that they evaporate almost immediately.

The water feeding an ultrasonic humidifier must be pure so that minerals and other contaminants are not vibrated into the air. Such purity is achieved with de-ionized (DI) water filters or reverse osmosis (RO) systems to remove all minerals and foreign matter from the water. DI water offers additional benefits. It assures a pure, healthy mist for those breathing the air, and it significantly reduces the amount of maintenance required for the humidifier, i.e. no scaling or sludge to be removed from the humidifier pan.

## **HUMIDIFIRST humidifier sizing calculations**

When calculating the humidification loads of a space we will generalize and assume that the majority of the humidification load will come from two areas:

1. **Ventilation, Exhaust, or Infiltration of air:** Most buildings have air exchanges with the outside because of one or more of these three items.
  - A. **Ventilation** is a result of air conditioning systems bringing outside air in to provide fresh air to the inhabitants.
  - B. **Exhaust** is the mechanical removal of air from a space when processes inside of the building require the removal of dirty, hot or unwanted air.
  - C. **Infiltration** occurs when air comes into a space from outside. Air may come in through small openings around doors, windows, ceilings, etc. Also, infiltration often occurs from frequent opening of doors.

For each **Cubic Foot per Minute (CFM)** of outside air that is brought into the space, moisture must be added to achieve your relative humidity requirements.

2. **Air conditioning:** When an air conditioner runs, it removes moisture from the air. This is known as Latent cooling. If the air conditioner will be running during your humidification season, you must take this dehumidification process into account. The cooling ability of an air conditioner is normally rated by the manufacturer and is stated in Sensible and Total cooling capacity in btu's per hour. Subtract the **Sensible** cooling capacity from the **Total** cooling capacity to get the **Latent** cooling capacity. For every 1000 btu's/hour of Latent cooling capacity you will need to add one pound of moisture.

Please note that there are other factors that can add to your humidification requirements, such as moisture absorption of items in your space. We generally ignore them because **most often** they play only a minor part of your humidification requirements. Contact us if you think you have unique requirements.

See the next page for a simple chart that you can fill in and send to us. We would be happy to assist you with sizing your humidification system.

**Physical dimensions of ABS MP5/15 humidifier modules**

<b>Humidifier Module</b>	<b>Capacity (#/hr)</b>	<b>Power used</b>	<b>Weight (lbs.)</b>	<b>Dimensions WxDxH (in.)</b>	<b>Number of Transducers</b>	<b>Fan CFM</b>
<b>MP-5</b>	<b>5</b>	<b>140 va</b>	<b>9</b>	<b>9.0 x 12.9 x 12.5</b>	<b>4</b>	<b>45</b>
<b>MP-15</b>	<b>15</b>	<b>420 va</b>	<b>12</b>	<b>21.0 x 12.9 x 12.5</b>	<b>12</b>	<b>90</b>

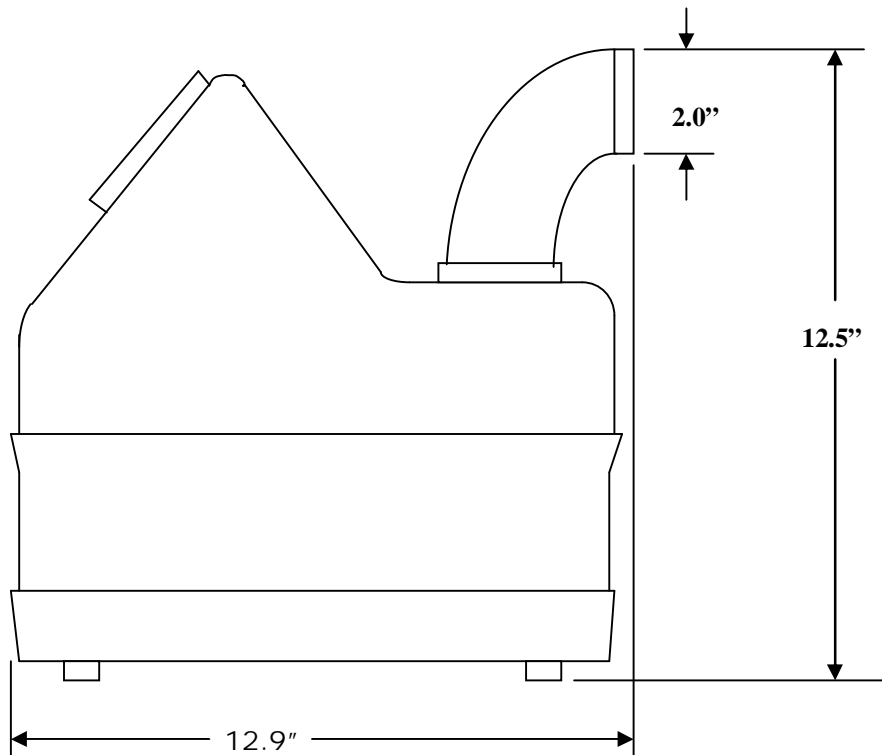

**Physical dimensions of SS MP18/25 humidifier modules**

<b>Humidifier Module</b>	<b>Capacity (#/hr)</b>	<b>Power used</b>	<b>Weight (lbs.)</b>	<b>Dimensions WxDxH (in.)</b>	<b>Number of Transducers</b>	<b>Fan CFM</b>
<b>MP-18</b>	<b>18</b>	<b>490 va</b>	<b>28</b>	<b>21.5 x 16.0 x 13.0</b>	<b>14</b>	<b>135</b>
<b>MP-25</b>	<b>25</b>	<b>700 va</b>	<b>42</b>	<b>29.0 x 16.0 x 13.0</b>	<b>20</b>	<b>180</b>

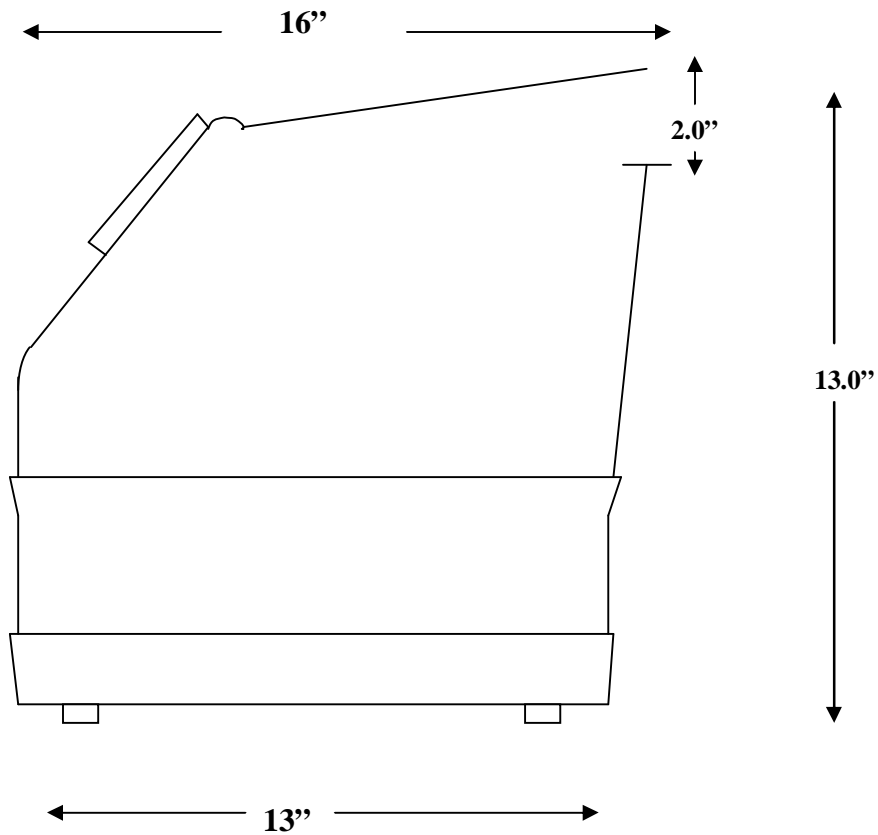

<b>Width:</b>	<b>MP-18</b>	<b>21.5"</b>	<b>MP-25</b>	<b>29.0"</b>
---------------	--------------	--------------	--------------	--------------

# MIST PAC MASTER POWER AND CONTROL PANEL

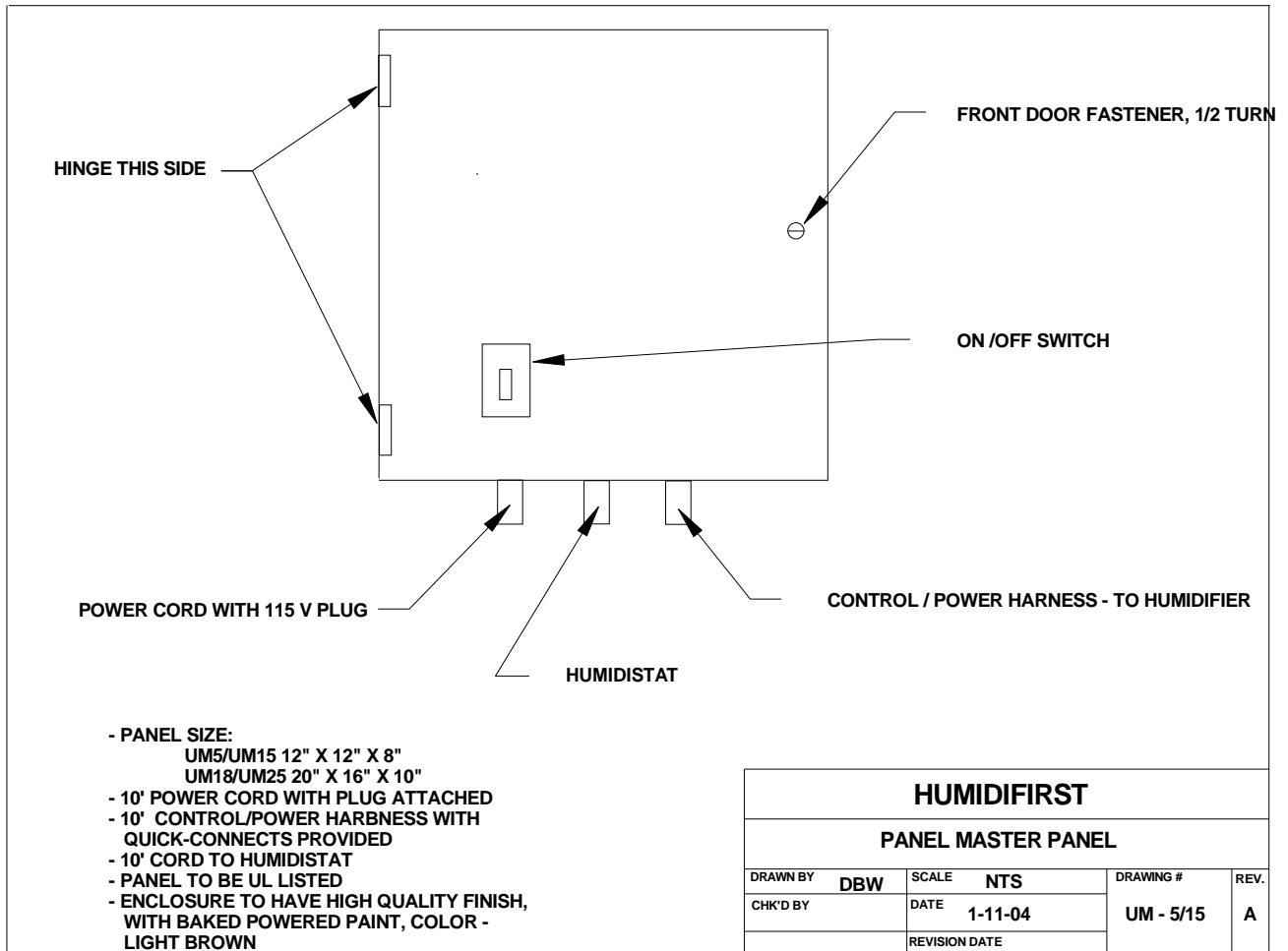



## **HUMIDIFIRST “Mist-Pac” Ultrasonic humidifier Specifications**

### **Humidifier module and Master Panel**

The humidifier shall be a packaged, self-contained ultrasonic humidifier using the principle of ultrasonic nebulization. Each humidifier shall use a multiple of ultrasonic transducers that vibrate at approximately 1.65 megahertz, producing a droplet size of approximately 1 micron. Each transducer circuit shall use the “thickness vibration method” of humidification via a piezoelectric converter. The ultrasonic transducers shall convert the electric energy into mechanical energy, causing the water to cavitate, resulting in the production on one micron sized water particles. The design of the humidifier housing shall prevent larger droplets from leaving the humidifier assembly.

The humidifier shall consume no more than 35 watts per pound of humidification generated.

The ultrasonic humidifier shall not produce any unacceptable noise. The sound level shall not exceed 50 db at 5 feet from the humidifier module  
The ultrasonic humidifier shall not require a flush cycle and shall have instant on and off operation in order to maintain precise room relative humidity.

The humidifier housing and discharge nozzles shall be made of high grade stainless steel or ABS plastic.

The system shall be pre-wired with quick connects provided to connect the Master Panel to the humidifier module. The Master Panel will be provided with:

1. Pre-wired humidistat with 10’ cord
2. 6’ power cord with 120 volt plug
3. 10’ power/control cord to connect the Master Panel to the humidifier

Each humidifier shall have the following components:

- A. 24vac Solenoid valve to control water flow into the humidifier
- B. One (1) Float switch that controls water level, transducer operation and provides low water shutdown.
- C. Piezoelectric crystals (transducers); Transducer Printed Circuit Boards with UL Recognized safety rating.
- D. A water tube connection kit to include a set of quick-disconnect service valves to easily isolate the humidifier when servicing.
- E. On/Off humidistat or Microprocessor based proportional control via analog input signals.
- F. Optional relay for field adjustable mist output control (“Ultra-Pulse”).

## **HUMIDIFIRST**

### **Positioning your Humidifirst ultrasonic humidifier system**

#### **Locating the humidifier module**

Properly locating the humidifier module is very important and by doing so will eliminate many potential problems. The MIST-PAC is designed for either shelf mounting or suspending from the ceiling. Ceiling suspended units should be hung at least two feet below the ceiling. Allow ten feet in front of and 6 feet below the unit for maximum mist evaporation. Of course, the evaporation rate will depend upon the relative humidity and temperature of the space. An optional mounting shelf can be equipped with an integrated booster fan to improve evaporation rate. **It is important that you locate the humidifier so that air currents do not cause the discharged mist to re-circulate back to the intake fan(s). This may cause failure of the fan(s) and internal electronic components.**

See the “Installation Parameters & Guidelines” on the following pages.

#### **Locating the Master Panel**

The Master Panel can be mounted on an adjacent wall or laid adjacent to the humidifier module. Care should be taken so that the panel cannot fall and cause harm to anyone.

The panel can be locked for security.

### **INSTALLATION REQUIREMENTS**

HUMIDIFIRST humidifiers are packaged humidifiers. The standard unit requires no field power or control wiring. It simply plugs into a standard 120 volt power receptacle (6 foot power cord included) and has a humidistat that is pre-wired to a ten (10) foot cable. The proportional control unit requires field power and control wiring, as it uses a wall mounted RH transmitter for microprocessor control, and it can be powered with 120v, 230v, or 480v.

The unit should be mounted so that it is level from side to side and from front to back.

The MP18/25 has a drain feature that can be connected to a manual valve or automatic solenoid to remove water from the humidifier. An optional mounting shelf with integrated booster fan allows for faster evaporation of discharged mist and shorter vapor trail for any Mist Pac humidifier models.

An optional Ultra-Pulse field adjustable relay on the Mist Pac allows for pre-set pulsing control of mist output to improve vapor evaporation.

## **INSTALLATION PARAMETERS & GUIDELINES**

### **MECHANICAL**

1. The supply air temperature to the humidifier modules should be between 40 F and 122 F at 90% relative humidity or less.
2. It is advisable that a safety drain pan be installed underneath the humidifier module and piped to the nearest drain.
3. The humidifier must be mounted level from front to back and from side to side.

### **WATER AND WATER PIPING**

1. Water supply pressure should be between 20 psi to 75 psi.
2. Water supply temperature should be between 40 F to 100 F.
3. Pure water, 2.5 parts per million (ppm) or cleaner, should be used in the humidifier. Water dirtier than 10 ppm can introduce dust into the air, which will eventually collect inside of the humidified space. Dirty water will shorten transducer life and will require more frequent humidifier maintenance.
4. Reverse osmosis systems or de-ionization bottles are typically used for water treatment. Please contact Humidifirst for sizing and/or selection of water treatment equipment. Undersized water treatment systems can cause damage to the humidification system.
5. Water piping to each humidifier should be designed for use with de-ionized water ie. stainless steel, appropriate plastic, etc.  
(check local building codes requirements)

### **ELECTRICAL**

1. Follow all local, state, and federal wiring guidelines.
2. Allowable voltage variance +/- 10%.
3. The power source should be provided with a circuit breaker.

**Before starting the humidification system:**

**CAUTION !!**

1. With the power to the Master control panel disconnected, make sure that all wire connections are tight. Excessive vibration during the shipping process can cause wire connections at terminals and electrical components to become loose.
2. Before operating the humidifier for the first time, remove the humidifier lid and pour water into the basin to a minimum depth of 1". This will help protect the transducers from failing if problems occurred during shipment.
3. Always make sure the humidifier is mounted on a flat surface so that water equally covers the transducers. Use a level to assure that the humidifier is mounted correctly.
4. Always have at least 20 PSI of water pressure connected to the humidifier module.

**Caution:**

- a. When water purification systems are used, pressure drops may be substantial and may reduce water flow to the humidifier.
- b. Never operate the humidifier continuously by "hand pouring" water into the humidifier. Running the humidifier for extended periods of time without 1.5" of water above the transducers will cause the transducers to fail. (The low water safety switch that is integral to the humidifier control is only used to prevent the humidifier from running dry. Also, not having water run through the water solenoid valve may cause it to overheat and fail.)
5. Never service the humidifier with the power connected.
6. Incorrect field wiring between the Master Panel and the humidifier module can cause immediate failure of all of the transducers.

## **STARTING UP YOUR SYSTEM FOR THE FIRST TIME**

First, make sure the system is ready to be started. This means that the humidifier module and Master Panel are mounted properly and are ready. All the water connections must be in place and supply water must be available. All electrical connections must be ready and the main power must be available.

1. Before the Humidifirst humidification system is started, the water supply lines that supply water to the humidifier module should be flushed for 5 minutes to ensure that the water lines are clean and free of debris.

If you are using a **Reverse Osmosis** system to purify your water, it may take as long as 45 minutes for water to start to flow. Even at peak flow, the Reverse Osmosis unit may only produce a trickle of water, which can lead to overheating of the transducers. (For example, One Mist-Pac 18 uses about 2 gallons per hour)

If you are using a **De-Ionization bottle** for water treatment, the water will start to flow in 5 to 15 minutes.

2. Remove the humidifier lid and pour water into the basin to a depth of 1”.
3. Before plugging the Master Panel into a 120 volt outlet check all electrical connections for tightness. Make sure the system is ready to be started and that all water and electrical connections are correct. Flip the fuses/circuit breakers to the “on” position before closing the lid.
4. Plug the power cord (if applicable) from the Master Panel into the 120-volt wall receptacle.
5. Turn the “On/Off” switch (located on the front of the Master Panel) to the “On” position.
6. Adjust the humidistat to the desired set point. It may take 5-45 minutes for the water level in the basin to rise to the required level (approximately 1 ½”) before the mist will start. If the mist does not start when the water level is reached, adjust the humidistat to a higher set point - the room relative humidity set point may already be satisfied or the humidistat may need calibrating.

**CAUTION: OPERATING THE TRANSDUCERS WITHOUT WATER COVERING THEM BY MANUALLY LIFTING THE FLOAT SWITCH WILL CAUSE THEIR IMMEDIATE FAILURE.**

7. To verify that the humidifier module is filling with water, you can briefly lift the lid of the humidifier module to visually inspect the water.
8. Once the humidifier module is full, the “low water safety” relay should switch to the “on” position and the humidifier module should start operating. This will not happen until there is approximately 1 ½” of water in the basin.
9. Visually inspect the humidifier modules for proper operation and the mist absorption path.

# OPTIONAL ULTRA-PULSE TIMER FOR MODULATING MIST OUTPUT

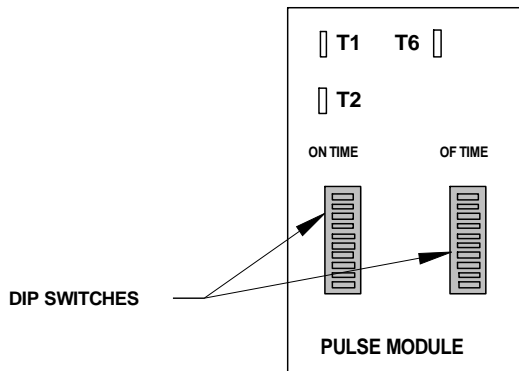

### SAFETY WARNING!

THE TIME PULSE MODULE IS LOCATED INSIDE OF THE MASTER PANEL. TO AVOID ELECTRIC SHOCK, UNPLUG POWER TO THE MASTER PANEL BEFORE MAKING ADJUSTMENTS TO THE PULSE MODULE.

#### OPERATING INSTRUCTIONS:

1. The humidifier module can be set for "time on" and "time off" periods.
2. Time adjustments can be made from 1 second to 1023 seconds.
3. The numbers adjacent to the DIP switches are the increments in seconds added when each switch is depressed to the right.  
For example, to achieve a three-second on-period, depress the "time on" DIP switches 1 & 2 to the right. To achieve a six-second off-period, depress the "time off" DIP switches 2 & 4 to the right. All other DIP switches should be depressed to the left.

<b>HUMIDIFIRST</b>				
<b>ULTRA-PULSE MASTER PANEL</b>				
DRAWN BY	DBW	SCALE	NTS	DRAWING #
CHK'D BY		DATE	5-31-05	UP - 101
		REVISION DATE		REV. A

## **TROUBLE SHOOTING**

**IMPORTANT !!! NEVER WORK ON THE HUMIDIFIER OR PANEL WHEN THE UNIT IS POWERED ON.**

Symptom:

1. The humidifier does not power up:
  - a. If you want the humidification system to operate and it will not, first make sure that there is a call for humidification and that the humidistat set-point is higher than the relative humidity in the space.
  - b. Make sure the on/off switch is in the “on” position.
  - c. There are fuses in the Master Control panel- one for the main input power and one each for 24 vac and 48 vac circuits. It is possible that a fuse is blown.
  - d. A surge arrestor protects the 24vac and 48vac circuits, and may be blown.

2. If water does not flow into the humidifier body:

Check that there is power to the humidifier first and make sure that there is a call for humidifier operation – turn the humidistat to the highest set-point.

- a. Check water source to confirm that the water is turned on.
- b. Make sure that all water connections are made.
- c. Check the fuses that are located in the Master Panel.
- d. Check the float switch in the humidifier body to ensure that it moves freely.
- e. Check the relays to ensure that they are pushed in firmly.
- f. Check all internal wiring connections and make sure that none are loose.
- g. Using a volt-meter, and referring to the wiring diagram, check to see that 24 volt power is going to the solenoid valve.
- h. If the above are checked and water does not flow to the humidifier basin then it should be assumed that the solenoid valve has failed and should be replaced.

## **HUMIDIFIRST**

3. The water solenoid valve does not shut off (read this page completely before starting to troubleshoot):

If the solenoid valve continues to allow water to pass when the humidifier power is shut off, there may be debris in the solenoid valve, preventing it from seating. If the solenoid valve stops water flow when the humidifier power is shut off, then an electrical problem is holding the solenoid valve open (ie. float switch or relay). Please note that the reed switches in a float switch may stick at times, causing a temporary problem. Lightning strikes or bad power may cause this. If this is an intermittent problem, the float switch should be replaced.

- a. If an electrical problem is keeping the solenoid valve open: (Warning – only qualified technicians should do this test as the Humidifirst Master Panel must be energized while making electrical measurements):

Call the factory to discuss the best way to test your humidifier. Depending on the model of the humidifier, the solenoid control relay may be wired Normally Open (NO) or Normally Closed (NC).

- b. If the solenoid valve does not shut off when the humidifier power is turned “off”, debris may be preventing the solenoid valve plunger from seating. This permits water to leak through it, causing the humidifier to overflow.

To inspect the valve for debris:

- 1) Remove the nut that holds the coil in place.
  - 2) Slide the coil housing off of the shaft.
  - 3) Grip the end of the shaft that is nearest to the threads with a set of pliers and turn counter-clockwise until the shaft is loose. Continue turning the shaft by hand until it unthreads from the valve housing. A spring-loaded plunger will come out of the end of the shaft. Confirm that there is no dirt on it or in the valve housing. Blow through the housing to clear any dirt that may have accumulated.
  - 4) Reassemble the valve.
  - 5) To test the valve, connect water to the unit and see if water drips from the water hose on the “discharge” side of the valve.
- c. Confirm that the humidifier has not been deprived of water. This can cause the solenoid valve to overheat and fail to open. Reverse osmosis water treatment systems can sometimes reduce water flow to the humidifiers and cause this to happen. Reduced water flow can occur when the water temperature drops or if the reverse osmosis membrane fails. If this is the case, replace the valve.



**TROUBLE SHOOTING (continued)**

4. If the transducers are not making a mist:

(Please note that after a call for humidification, it may take up to 45 minutes for the humidifier body to fill with water, depending on the type of water treatment system you are using. The transducers will not operate until the low water safety switch is satisfied.)

- a. Set the humidistat to the highest RH level to make sure the humidistat is calling for the humidifier to operate.
- b. Check that there is power to the humidifier. The power-on switch should be lit.
- c. Check to ensure that there is adequate water in the humidifier body (approximately 1.5 inches).
- d. Check the control relays to ensure that they are firmly in place and wired tight.
- e. Using a volt-meter, and referring to the wiring diagram, check to see that 48 volt power is going to the transducers. If so, then the transducers are failed.
- f. Check wire connections and make sure that they are tight.
- g. Check the humidifier's fan filters to determine whether they are clogged.

**Trouble shooting after the humidifier has operated for a period of time**

1. *The transducers are so covered with deposits that they do not work properly and the “finger” column of water that is generated is very small and puts out little mist.* The transducers must be kept clean. The time period between cleanings will be dependent upon the cleanliness of the air and water. Drain the humidifier module, and clean it with a mild vinegar and water solution. Sometimes the transducers may get coated with an oily substance, typically coming from new PVC or stainless steel pipe. If this is the case, try washing the basin and transducers with a mild dishwasher liquid solution.
2. *Some of the transducers run and some do not:* How long has the humidifier module been in operation? The average life span of the transducer is 10,000 hours. If some of them operate and some do not, it indicates that some of the transducers may have run their lifespan and need replacement. Peeling, surface bubbling and cracking are an indication of this. If the transducers are discolored it means that overheating has depolarized the transducer material and destroyed them.

## **MAINTENANCE**

### **Basic Maintenance**

Maintenance of Humidifirst Ultrasonic humidifiers is very simple and plays an important part in keeping the humidifier modules operating properly and extending the life of the components inside. At two weeks after start-up, the humidifier modules should be inspected with the lid off to determine if cleaning of the transducers is necessary. (To clean, follow steps 1 – 5 below). After that, they should be cleaned as often as is necessary, depending upon the cleanliness of the air and water going through them. The procedure for cleaning the humidifier modules is as follows:

1. Make sure that the power supply is disconnected.
2. The humidifier modules should be completely drained and the mist diffuser removed.
3. The humidifier basin and transducers should be cleaned thoroughly using a clean, soft cloth with a weak vinegar and water solution. **Never scrape the transducer surfaces or use abrasive cleaners as this may cause damage.** Typical kitchen cleaners can be used but make sure that the cleaner does not advertise a “shining” agent. Shining agents can leave a film on the transducers, which will reduce the mist output.
4. The basin and mist diffuser should be rinsed completely.
5. Clean the air filters (dirty filters will restrict airflow and overheat the transducers).

Disconnect the power cord to the Master control panel and check all the wiring connections for tightness. This should be checked a minimum of two times per year.

### **Transducers**

The transducers and the printed circuit driver board produce the mist. The normal life of a transducer can differ depending upon several variables. Typically, the operating life of the transducer is around 10,000 hours. See “Basic Maintenance” above for cleaning directions. The following variables will affect the life of the transducer.

1. The mineral content of the water affects the length of the transducer life. The cleaner the water, the longer the transducers will last.
2. Reduced or restricted air flow will cause premature failure of the transducers.
3. High entering water temperature will cause premature failure of the transducers.
4. High entering air temperature (above 122 ° F) may cause premature failure of the transducers.
5. Excessively dirty air can soil the transducers and reduce the transducer output. Caked on debris could cause overheating of the transducers and eventual failure.
6. Poor water pressure may not allow proper water flow into the humidifier basin. A water level in the basin of less than 1 ½” may cause the water to become hot and therefore cause transducer failure.

## **Maintenance (continued)**

### **End of humidifying season shutdown**

The humidifier Master Panel should be powered off when the humidification system will not be required for long periods of time. This will stop heat gain from the transformer. This will also reduce wear on the electrical components that may occur during summer storms. Shut off the power from the Building electric panel that feeds the Humidifirst Master Panel or unplug the individual humidifier control/power panels. Also, empty the water from the humidifier basin and wipe dry.

### **Humidistat**

The humidistat is tested before it ships. An instruction manual is included with documents that accompany the shipment.

### **Warranty**

The warranty for the humidifier module and the Master Panel is for one year from the date of start-up or 18 months from shipment, whichever comes first. Please find and complete the "HUMIDIFIRST MIST PAC START-UP FORM". There will be no warranty of the equipment without the form being completed and returned to Humidifirst. This warranty does not include labor. The warranty is for parts only. Spare parts are under warranty for 60 days from the date of shipment. Humidifier modules controlled by non-Humidifirst control boxes carry no warranty. For warranty to apply, the customer must use, operate, service, clean and maintain the humidifier system in accordance with this manual.

### **Manual Disclaimer**

Humidifirst has made every effort to assure accuracy in the manual, and assumes no responsibility and disclaims all liability for damages resulting from the use of this information or for any errors or omissions.

**HUMIDIFIRST MIST PAC START-UP FORM**

Important – Read the complete Owner’s Manual before starting your Humidifirst Ultrasonic Humidification system. Failure to read and understand the Owner’s Manual may result in incorrect wiring, installation, and operation of the system and could cause immediate harm to YOU and/or the humidification system.

Please complete the following checklist and return it to Humidifirst. There will be no warranty of the equipment without the form being completed and returned in a timely manner.

<p><b>The End User/Owner of the Humidification System:</b></p> <p>Company name: _____</p> <p>Company location: City _____</p> <p>State: _____</p>
<p><b>Serial number of the Master Panel:</b> _____</p> <p><b>For Zone:</b> _____</p>
<p><b>Installer of the humidification System:</b></p> <p>Company name: _____</p> <p>Company phone number: _____</p>
<p><b>Start-up of the system is being completed by:</b></p> <p>Name: _____</p> <p>Company name: _____</p> <p>Phone number: _____</p> <p>Signature* : _____</p> <p>Date of Start-up: _____</p>

By signing the above you are representing that the following information is accurate to the best of your knowledge.

**HUMIDIFIRST MIST PAC START-UP FORM**

Master Panel serial number: \_\_\_\_\_

Name of person doing start-up: \_\_\_\_\_

1. First, and most important, did you read the complete Owner's manual before starting the humidifier? \_\_\_\_\_ yes \_\_\_\_\_ no

Complete the following:

2. The humidifier is Shelf mounted \_\_\_\_\_ or is Suspended from the ceiling \_\_\_\_\_.

- a) The distance from the top of the humidifier to the ceiling is \_\_\_\_\_ feet.
- b) The distance from the bottom of the humidifier to the floor is \_\_\_\_\_ feet.
- c) The distance horizontally from the front of the humidifier to the nearest object is \_\_\_\_\_ feet.
- d) Is the humidifier located so that air currents in the space will not cause the mist to re-circulate into the intake fans? \_\_\_\_\_ yes \_\_\_\_\_ no
- e) Is the humidifier module mounted level from side to side? \_\_\_\_\_ yes
- f) Is the humidifier module mounted level from front to back? \_\_\_\_\_ yes
- g) Is a drain pan located under the humidifier module? \_\_\_\_\_ yes \_\_\_\_\_ no
- h) Is the water being purified by: a de-ionization bottle \_\_\_\_\_  
a Reverse osmosis/de-ionization system \_\_\_\_\_  
no water treatment being used \_\_\_\_\_

3. What is the quality of the non-treated water? \_\_\_\_\_ Parts Per Million (ppm)

4. Disconnect the water tube at the humidifier and allow water to run from the tube for 10 minutes. Does a reasonable amount of water come out of the tube? \_\_\_\_\_ yes \_\_\_\_\_ no

5. Cold water is connected to the humidifier and/or water treatment system. \_\_\_\_\_ yes

6. The room design conditions are \_\_\_\_\_ °F and \_\_\_\_\_ % Relative Humidity.

**HUMIDIFIRST MIST PAC START-UP FORM**

Master Panel serial number: \_\_\_\_\_

Name of person doing start-up: \_\_\_\_\_

**7. Have all wire connections in the Master control panel been tightened? (Make sure the power to the panel has been turned off while tightening.**

\_\_\_\_\_ **yes**

\_\_\_\_\_ **no**

**8. The humidifier has been operated for 30 minutes and the solenoid valve cycles on and off automatically .**

\_\_\_\_\_ **yes**

\_\_\_\_\_ **no**

**HUMIDIFIRST**

***HUMIDIFIRST***

ULTRASONIC HUMIDIFIERS

1315 Neptune Dr., Boynton Beach, FL 33426  
Ph. (561) 752-1936 Fax (801) 760-2777 [www.humidifirst.com](http://www.humidifirst.com)