

USER'S INFORMATION MANUAL



Models HD101-HD401 Type H



WARNING: If the information in this manual is not followed exactly, a fire or explosion may result causing property damage, personal injury or loss of life.

Do not store or use gasoline or other flammable vapors and liquids or other combustible materials in the vicinity of this or any other appliance. To do so may result in an explosion or fire.

WHAT TO DO IF YOU SMELL GAS:

- Do not try to light any appliance.
- Do not touch any electrical switch; do not use any phone in your building.
- Immediately call your gas supplier from a neighbor's phone. Follow the gas supplier's instructions.
- If you cannot reach your gas supplier, call the fire department.

Installation and service must be performed by a qualified installer, service agency or the gas supplier.

AVERTISSEMENT: Assurez-vous de bien suivre les instructions données dans cette notice pour réduire au minimum le risque d'incendie ou d'explosion ou pour éviter tout dommage matériel, toute blessure ou la mort.

Ne pas entreposer ni utiliser d'essence ni d'autres vapeurs ou liquides inflammables dans le voisinage de cet appareil ou de tout autre appareil.

QUE FAIRE SI VOUS SENTEZ UNE ODEUR DE GAZ:

- Ne pas tenter d'allumer d'appareils.
- Ne touchez à aucun interrupteur. Ne pas vous servir des téléphones dans le bâtiment où vous vous trouvez.
- Appelez immédiatement votre fournisseur de gaz depuis un voisin. Suivez les instructions du fournisseur.
- Si vous ne pouvez rejoindre le fournisseur de gaz, appelez le service des incendies.

L'installation et l'entretien doivent être assurés par un installateur ou un service d'entretien qualifié ou par le fournisseur de gaz.

Raypak®
A Rheem® Company

WARNINGS

Pay Attention to These Terms

DANGER:	Indicates the presence of immediate hazards which will cause severe personal injury, death or substantial property damage if ignored.
WARNING:	Indicates the presence of hazards or unsafe practices which could cause severe personal injury, death or substantial property damage if ignored.
CAUTION:	Indicates the presence of hazards or unsafe practices which could cause minor personal injury or product or property damage if ignored.
NOTE:	Indicates special instructions on installation, operation, or maintenance which are important but not related to personal injury hazards.

DANGER: Make sure the gas on which the boiler will operate is the same type as that specified on the boiler rating plate.

WARNING: Do not use this boiler if any part has been under water. Immediately call a qualified service technician to inspect the boiler and to replace any part of the control system and any gas control which has been under water.

WARNING: To minimize the possibility of improper operation, serious personal injury, fire, or damage to the boiler:

- Always keep the area around the boiler free of combustible materials, gasoline, and other flammable liquids and vapors.
- Boiler should never be covered or have any blockage to the flow of fresh air to the heater.

WARNING: Risk of electrical shock. More than one disconnect switch may be required to de-energize the equipment before servicing.

WARNING: Should overheating occur or the gas supply fail to shut off, do not turn off or disconnect the electrical supply to the pump. Instead, shut off the gas supply at a location external to the appliance.

AVERTISSEMENT: En cas de surchauffe ou si l'admission de gaz ne peut être coupée, ne pas couper ni débrancher l'alimentation électrique de la pompe. Fermer plutôt le robinet d'admission de gaz à l'extérieur de l'appareil.

WARNING - CALIFORNIA PROPOSITION 65: This product contains chemicals known to the State of California to cause cancer, birth defects or other reproductive harm.

WARNING: Improper installation, adjustment, alteration, service or maintenance can cause property damage, personal injury, exposure to hazardous materials* or loss of life. Review the information in this manual carefully. *This unit contains materials that have been identified as carcinogenic, or possibly carcinogenic, to humans.

CAUTION: If this boiler is to be installed above radiation level, it must be provided with a low water cut-off device at the time of boiler installation.

CAUTION: This boiler requires forced water circulation when the burner is operating. Severe damage will occur if the boiler is operated without proper water flow circulation.

CAUTION: If this boiler is to be installed in a negative or positive pressure equipment room, there are special installation requirements. Consult factory for details.

NOTE: This manual should be maintained in legible condition and kept adjacent to the boiler or in another safe place for future reference.

FOR YOUR SAFETY READ BEFORE OPERATING POUR VOTRE SÉCURITÉ LISEZ AVANT DE METTRE EN MARCHÉ



WARNING: If you do not follow these instructions exactly, a fire or explosion may result causing property damage, personal injury or loss of life.



AVERTISSEMENT: Quiconque ne respecte pas à la lettre les instructions dans la présente notice risque de déclencher un incendie ou une explosion entraînant des dommages, des blessures ou la mort.

- A. This appliance does not have a pilot. It is equipped with an ignition device which automatically lights the burner. Do not try to light the burner by hand.
- B. BEFORE OPERATING, smell all around the appliance area for gas. Be sure to smell next to the floor because some gas is heavier than air and will settle on the floor.
WHAT TO DO IF YOU SMELL GAS
 - * Do not try to light any appliance.
 - * Do not touch any electric switch; do not use any phone in your building.
 - * Immediately call your gas supplier from a neighbor's phone. Follow the gas supplier's instructions.
 - * If you cannot reach your gas supplier, call the fire department.
- C. Use only your hand to push in or turn the gas control knob. Never use tools. If the knob will not push in or turn by hand, do not try to repair it, call a qualified service technician. Force or attempted repair may result in a fire or explosion.
- D. Do not use this appliance if any part has been under water. Immediately call a qualified service technician to inspect the appliance and to replace any part of the control system and any gas control which has been under water.

- A. Cet appareil ne comporte pas de veilleuse. Il est muni d'un dispositif d'allumage qui allume automatiquement le brûleur. Ne tentez pas d'allumer le brûleur manuellement.
- B. AVANT DE FAIRE FONCTIONNER, renifliez tout autour de l'appareil pour détecter une odeur de gaz. Remplissez près du plancher, car certains gaz sont plus lourds que l'air et peuvent s'accumuler au niveau du sol. QUE FAIRE SI VOUS SENTEZ UNE ODEUR DE GAZ:
 - * Ne pas tenter d'allumer l'appareil.
 - * Ne touchez à aucun interrupteur; ne pas vous servir des téléphones se trouvant dans le bâtiment.
 - * Appelez immédiatement votre fournisseur de gaz depuis un voisin. Suivez les instructions du fournisseur.
 - * Si vous ne pouvez rejoindre le fournisseur, appelez le service des incendies.
- C. Ne poussez ou tournez la manette d'admission du gaz qu'à la main; ne jamais utiliser d'outil. Si la manette reste coincée, ne pas tenter de la réparer; appelez un technicien qualifié. Le fait de forcer la manette ou de la réparer peut déclencher une explosion ou un incendie.
- D. N'utilisez pas cet appareil s'il a été plongé dans l'eau même partiellement. Faites inspecter l'appareil par un technicien qualifié et remplacez toute partie du système de contrôle et toute commande qui ont été plongés dans l'eau.

OPERATING INSTRUCTIONS/INSTRUCTIONS DE MISE EN MARCHÉ

1. **STOPI!** Read the safety information above on this label.
2. Set the thermostat to the lowest setting.
3. Turn off all electric power to the appliance.
4. This appliance does not have a pilot. It is equipped with an ignition device which automatically lights the burner. Do not try to light the burner by hand.
5. Remove heater door panel.
6. Turn gas control knob clockwise  to "OFF". (Or push switch to "OFF".)
7. Wait five (5) minutes to clear out any gas. Then smell for gas, including near the floor. If you smell gas STOP! Follow "B" in the safety information above on this label. If you don't smell gas, go to the next step.
8. Turn gas control knob counter clockwise  to "ON". (Or push switch to "ON".)
9. Replace heater door panel.
10. Turn on all electric power to the appliance.
11. Set thermostat to desired setting.
12. If the appliance will not operate, follow the instructions "To Turn Off Gas To Appliance" and call your service technician or gas supplier.

1. **ARRÊTEZ!** Lisez les instructions de sécurité sur la portion supérieure de cette étiquette.
2. Réglez le thermostat à la température la plus basse.
3. Coupez l'alimentation électrique de l'appareil.
4. Cet appareil ne comporte pas de veilleuse. Il est muni d'un dispositif d'allumage qui allume automatiquement le brûleur. Ne tentez pas d'allumer le brûleur manuellement.
5. Enlevez le panneau de porte du réchauffeur.
6. Tournez le bouton de la vamme de gaz dans le sens horaire  à la position "Arrêt" (OFF). (Ou poussez le bouton à la position "Arrêt".)
7. Attendez cinq (5) minutes pour laisser échapper tout le gaz. Renifliez tout autour de l'appareil, y compris près du plancher, pour détecter une odeur de gaz. Si vous sentez une odeur de gaz, ARRÊTEZ! Passez à l'étape "B" des instructions de sécurité sur la portion supérieure de cette étiquette. S'il n'y a pas d'odeur de gaz, passez à l'étape suivante.
8. Tournez le bouton de commande de gaz dans le sens antihoraire  à la position "Marche" (ON). (Ou poussez le bouton à la position "Marche".)
9. Remplacez le panneau de porte du réchauffeur.
10. Mettez l'appareil sous tension.
11. Réglez le thermostat à la température désirée.
12. Si l'appareil ne se met pas en marche, suivez les instructions intitulées "Comment couper l'admission de gaz de l'appareil" et appelez un technicien qualifié ou le fournisseur de gaz.

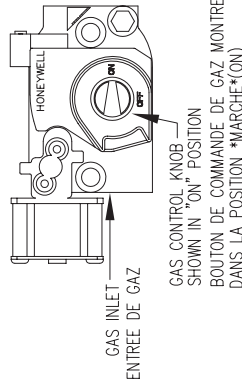
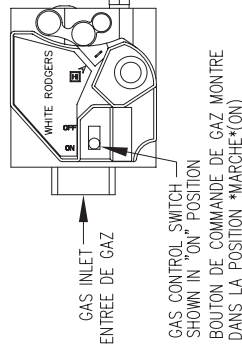
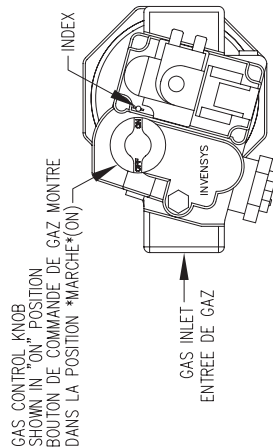

TO TURN OFF GAS TO APPLIANCE/COMMENT COUPER L'ADMISSION DE GAZ L'APPAREIL

1. Set the thermostat to the lowest setting.
 2. Turn off all electrical power to the appliance if service is to be performed.
 3. Remove heater door panel.
 4. Turn gas control knob clockwise  to "OFF". (Or push switch to "OFF".)
 5. Replace heater door panel.
1. Réglez le thermostat à la température la plus basse.
 2. Coupez l'alimentation électrique de l'appareil s'il faut procéder à l'entretien.
 3. Enlevez le panneau de porte du réchauffeur.
 4. Tournez le bouton de commande de gaz dans le sens horaire à la position "Arrêt" (OFF). (Ou poussez le bouton à la position "Arrêt".)
 5. Remplacez le panneau de porte du réchauffeur.

Component Locations

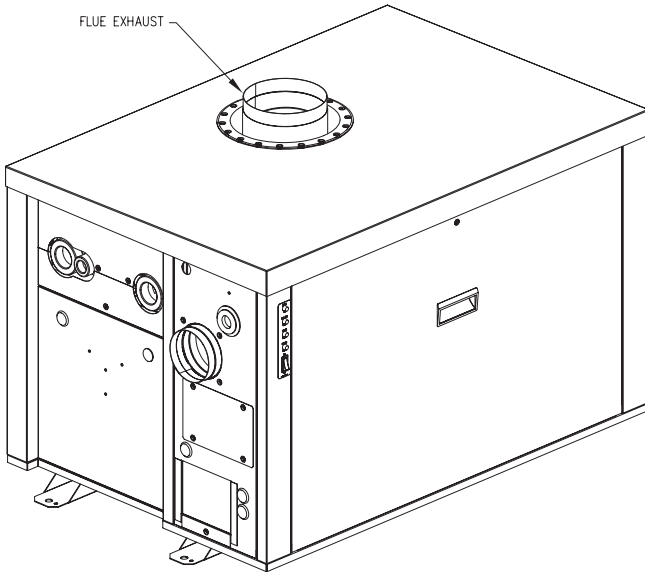

Fig. 1: Component Locations – Angle

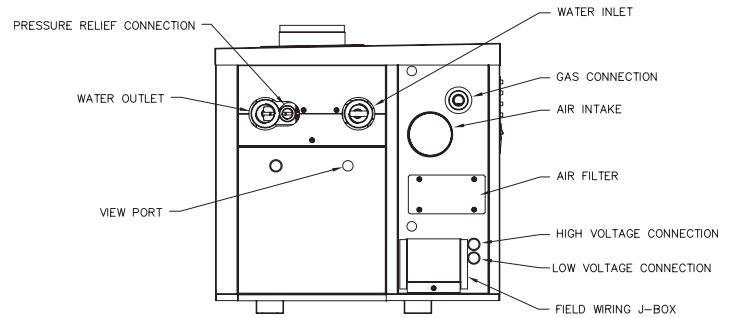

Fig. 2: Component Locations – Left Side

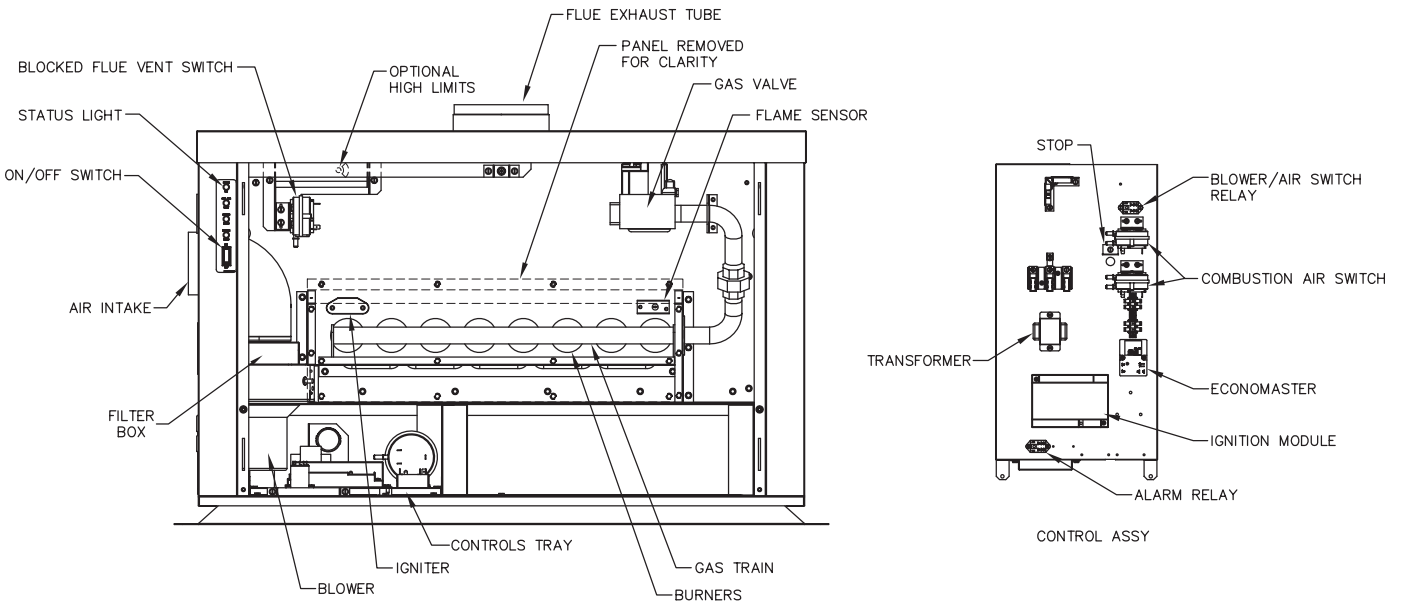

Fig. 3: Component Locations – Front

MAINTENANCE

Suggested Minimum Maintenance Schedule:

Regular service by a qualified service agency and maintenance must be performed to ensure maximum heater operating efficiency. Maintenance as outlined below may be performed by the owner.

Yearly (Beginning of each heating season):

1. Annual service call by qualified service agency.
2. Visually check top of vent for soot. Call service person to clean. Some sediment at bottom of vent is normal.
3. Visually inspect venting system for proper function, deterioration or leakage.
4. Check that heater area is free from combustible materials, gasoline, and other flammable vapors and liquids.
5. Check for and remove any obstruction to the flow of combustion or ventilation air to heater.
6. Follow pre-start-up check in the Initial Start-up section.
7. Visually inspect burner flame. Should see light blue flame. Visually inspect hot surface igniter for damage, cracking or debris build-up.
8. Check operation of safety devices. Refer to manufacturer's instructions.
9. Follow oil-lubricating instructions on circulator (if required). Over-oiling will damage circulator. Water-lubricated circulators do not need oiling.
10. To avoid potential of severe burn, DO NOT REST HANDS ON OR GRASP PIPES. Use a light touch - return piping will heat up quickly.
11. Check blower and blower motor. Clean and oil as necessary.
12. Check for piping leaks around circulators, relief valves and other fittings. Repair, if found. DO NOT use petroleum based stop leak.

13. Check air filter and replace if necessary.

Daily:

1. Check that heater area is free from combustible materials, gasoline, and other flammable vapors and liquids.
2. Check for and remove any obstruction to the flow of combustion or ventilation air to heater.

Monthly:

1. Check for piping leaks around circulators, mixing valves, relief valves, and other fittings. If found, repair at once. DO NOT use petroleum-based stop leak compounds.
2. Visually inspect burner flame.
3. Visually inspect venting system for proper function, deterioration or leakage.
4. Check air vents for leakage.

Quarterly:

1. Check relief valve. Refer to manufacturer's instructions on valve.
2. Test low water cut-off, if used. Refer to manufacturer's instructions.
3. Check the air filter; replace if necessary.



www.raypak.com

Raypak, Inc., 2151 Eastman Avenue, Oxnard, CA 93030 (805) 278-5300 Fax (805) 278-5468
Litho in U.S.A.