



# First Place in Corrosion Protection

- Cupro-Nickel Indirect Heat Exchanger  
Optional Titanium Heat Exchanger
- 7" TouchScreen Display – Easy-to-Use
- PVC Venting
- 96% Thermal Efficiency



XTherm® Indirect  
Pool Heaters  
SIZES 1.0 • 1.5 • 2.0 MMBTU

[www.raypak.com](http://www.raypak.com)

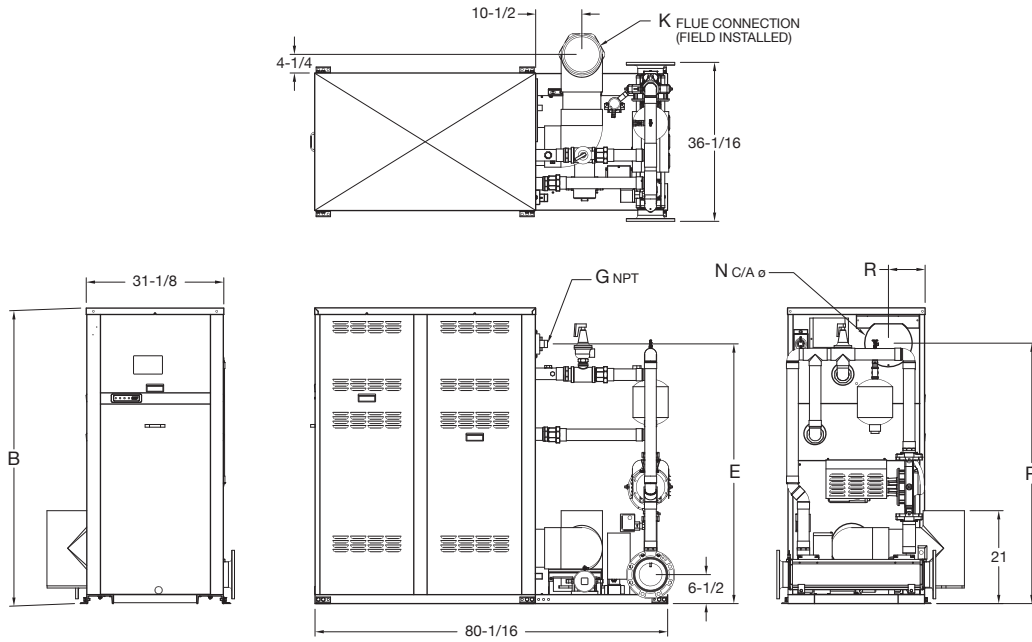

Model (H7-)	MBTUH		Dimensions (in)						Ship Weight (Lbs.)	
	In	Out	B Height	E	G* NPT	K Flue ø	N C/A ø	P		R
1005A	999	969	55-1/4	47	1-1/4	6	6	47-1/8	8-5/16	1343
1505A	1500	1455	67-1/8	59	1-1/4	8	8	59-1/8	8-3/16	1448

\*For Propane Gas, all models are 1" NPT.

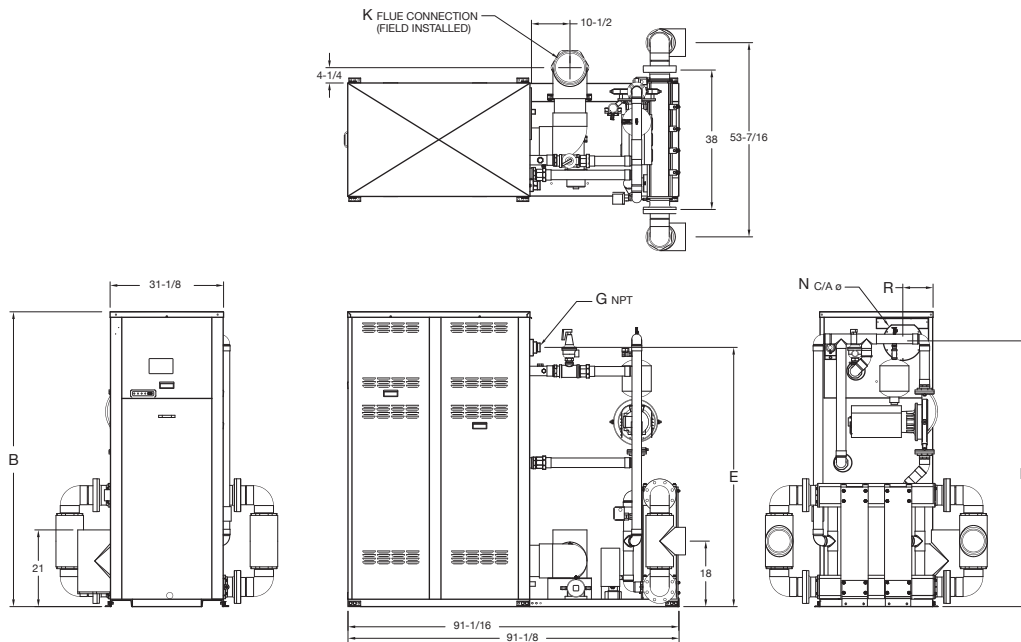

Model (H7-)	MBTUH		Dimensions (in)						Ship Weight (Lbs.)	
	In	Out	B Height	E	G* NPT	K Flue ø	N C/A ø	P		R
2005A	1999	1939	81-1/8	72	2	8	8	73-1/8	8-3/16	1930

\*For Propane Gas, all models are 1" NPT.

All models approved for outdoor installation.



Litho in U.S.A. ©2018 Raypak, Inc.  
 2151 Eastman Ave., Oxnard, CA 93030  
 805-278-5300  
 6200.11 Effective 01-15-18