

XV^{ers}™

CONDENSING FIRE-TUBE



INSTALLATION
VERSATILITY

SMARTER
CONTROLS

MAXIMUM
EFFICIENCY

Select the most versatile
and adaptive commercial
boiler ever!

Raypak



INSTALLATION VERSATILITY

No one else takes the worry away from the project.



Easy to Move

No need for long delays, heavy equipment or extra rigging costs. XVers has pallet supports built right in, so you can move it with a pallet jack or forklift whenever you need.



Easy to Fit

Retrofit into existing systems with ease or enjoy the small footprint in new builds. Get the cost savings and performance you expect from Raypak with the right fittings to make it easy.



Easy to Get It Right

Adaptable controls that support multiple piping, venting and operational configurations for ease of installation, integration and longevity.

Retractable combustion air intake connector

7 inch HD color touch screen user interface

MERV 8 combustion air filter

Low voltage conduit connection

Hinged control panel covers for easy access



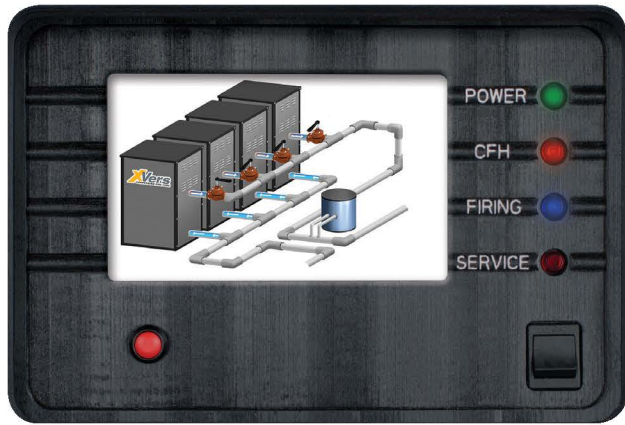

Raypak's capacitive 7" Touch Screen (TS) is the very latest in high-performance, touch screen displays. The thick ballistic cover glass, along with the water-resistant and glove-enabled touch panel, provides the rugged features required in today's equipment room. The Raypak TS comes with 4GB of onboard flash storage and 4GB of DDR2 SDRAM, allowing for fast rendering of high-resolution images as well as ample storage for monitoring / diagnostic data.

SMARTER CONTROLS

No one else has
built-in intelligence.

XVers comes with automated controls that are easy to set up, understand and use, with a 7 inch full HD, capacitive color touch screen display with ballistic glass overlay and Glove Sense™ technology for the most robust display in the industry.

Connect to your Building Management System (BMS) in minutes, or use one of our gateways for even more flexibility.

No more complicated math. Simply tell the XVers during commissioning what concentration of glycol is in your system and what vent material you have chosen and it does the rest!

The XVers integrated Versa IC® control system can be configured to operate a wide array of accessories. When configured in primary loop piping configurations, the XVers can control single or multiple motorized isolation valves. If the XVers is configured for primary-secondary piping, the XVers can provide a proportional output to a variable-speed boiler pump to enhance system performance and save electrical energy when operating at part load.

The XVers can also be configured to control a motorized combustion air damper as well as connect to various exhaust fan control systems when needed for maximum installation versatility.

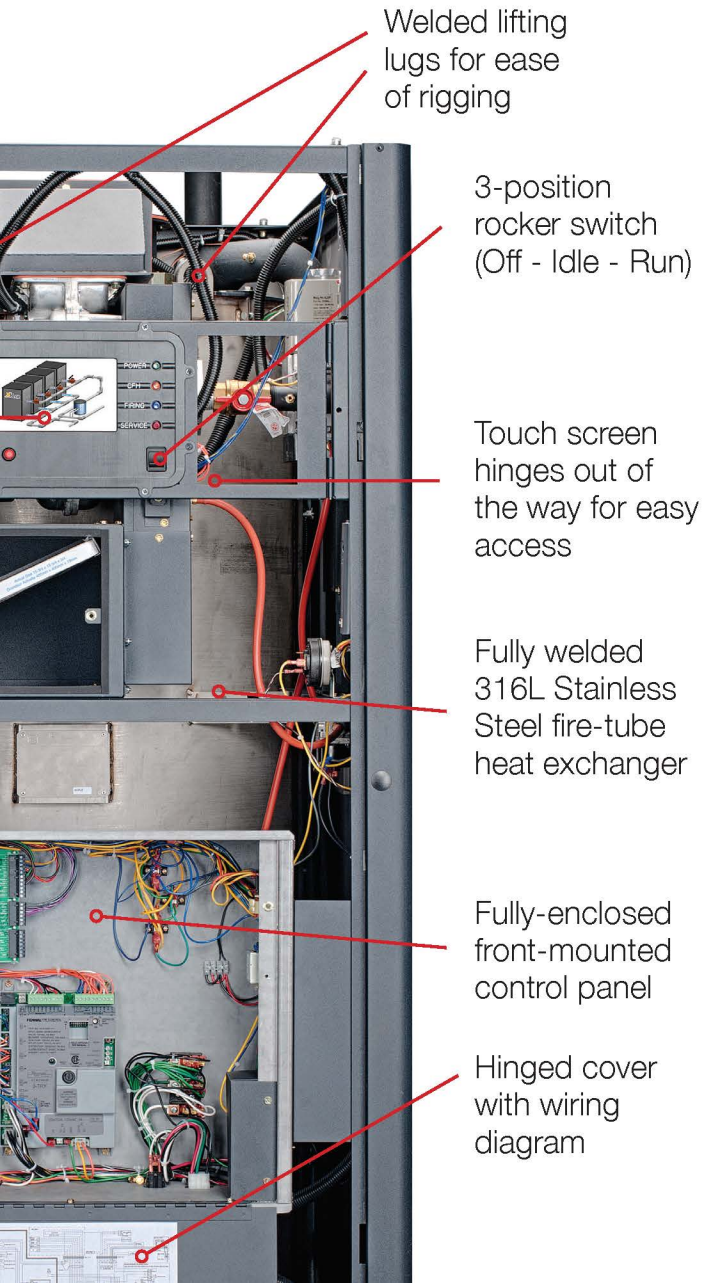

Welded lifting lugs for ease of rigging

3-position rocker switch (Off - Idle - Run)

Touch screen hinges out of the way for easy access

Fully welded 316L Stainless Steel fire-tube heat exchanger

Fully-enclosed front-mounted control panel

Hinged cover with wiring diagram



Want More
Information?

visit www.raypak.com



Works the way you need it to.

XVers, as the name suggests, are designed to be “**Extremely Versatile.**” Equipped with the Versa IC integrated control system, XVers are capable of operating a single boiler or cascade of boilers for a multitude of system types, including:

- Primary loop hydronic
- Variable-flow primary loop hydronic
- Primary-secondary hydronic
- Variable-flow primary-secondary hydronic

Features That Give You Installation Versatility

- Flip-latch door locks that double as handles
- Built-in lifting lugs to accommodate easy rigging by cranes
- Safety certified for indoor/outdoor installation
- Multi-voltage capabilities
- 115VAC, 5A built-in receptacle to assist installers
- Multiple venting options: PVC, CPVC, polypropylene or stainless steel

Features That Give You Smarter Controls

- Water Flow Sensor to measure water flow rate
- Delta T Control to gauge temperature differences
- Vent Temperature Sensor to protect vent system
- “Rich-Start” Control to ensure ignition in various conditions
- Capacitive Color Touch screen
- Automated monitoring of flue gas temperature
- Automated control of boiler output

Features That Give You Maximum Efficiency

- Up to 15 to 1 turndown for optimum load tracking
- Characterized fire-tubes for enhanced heat transfer
- Built-in flue gas analysis port to ease tuning
- Variable-speed boiler pump control to save on pump energy
- Integral air filter to enhance burner operation and life

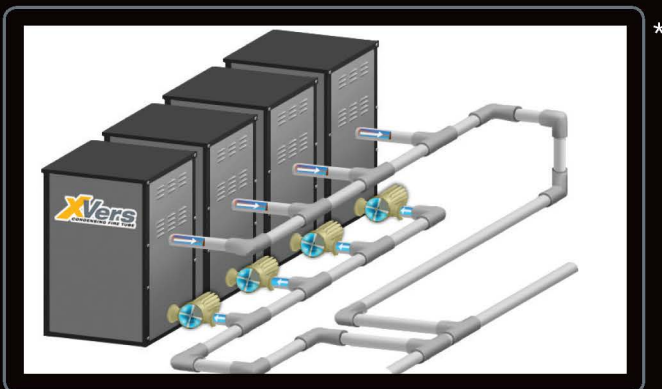

Variable-flow Primary-Secondary System *

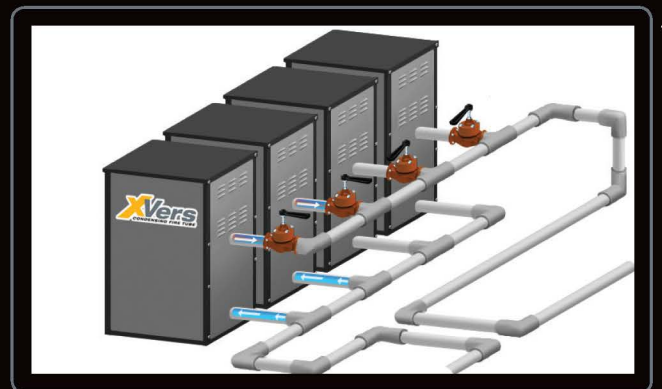

Variable-flow Primary piping system *

*Actual images from color touch screen display

FINALLY GET THE FEATURES YOU WANT

XVers is the most versatile condensing fire-tube boiler available.



MAXIMUM EFFICIENCY

MAXIMUM PERFORMANCE

Industry leading operating efficiency

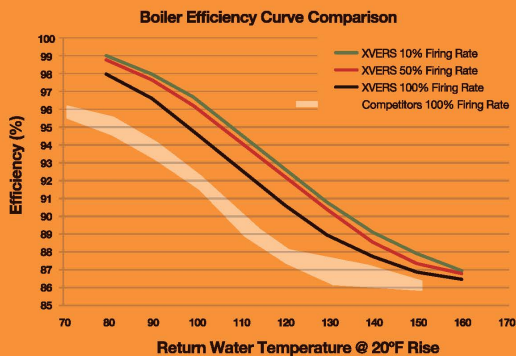

MAXIMUM VENTING OPTIONS

Control adapts to vent material selection

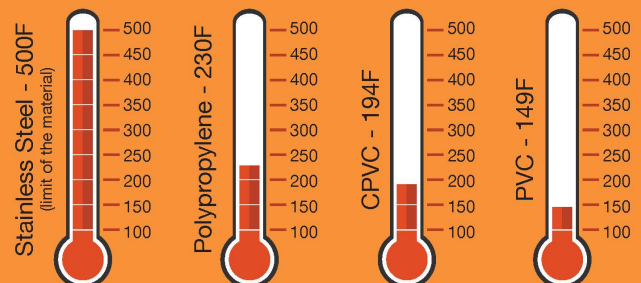



XVers - Type H Models 0856 - 3006

Model (H7-)	MBTUH (kw/h)		Turn Down	AHRI Thermal Efficiency	Dimensions In. (mm)								Ship Weight Lbs.(kg)	
	Input	Output			A Height	B Width	C Base Depth	D Overall Depth	E	F	G NPT	K Flue Ø		N C/A Ø
☐ 0856	855 (250.6)	822.5 (241.1)	8 to 1	96.2	78 (1981)	30 (762)	51.3 (1303)	60.2 (1529)	12-1/8 (308)	12-1/2 (318)	1-1/4	6	6	1596 (724)
☐ 1006	999 (292.8)	961 (281.6)	9 to 1	96.2	78 (1981)	30 (762)	51.3 (1303)	60.2 (1529)			1-1/4	6	6	1596 (724)
☐ 1256	1250 (366.3)	1202.5 (352.4)	13 to 1	96.2	78 (1981)	30 (762)	54.4 (1382)	63.4 (1610)			1-1/4	8	6	1960 (889)
☐ 1506	1500 (439.6)	1443 (422.9)	15 to 1	96.2	78 (1981)	30 (762)	54.4 (1382)	63.4 (1610)			1-1/4	8	6	1960 (889)
☐ 1756	1750 (512.9)	1683.5 (493.4)	8 to 1	96.2	78 (1981)	34 (864)	56.5 (1435)	65.7 (1669)			2	8	8	2080 (943)
☐ 2006	1999 (585.8)	1923 (563.6)	9 to 1	96.2	78 (1981)	34 (864)	56.5 (1435)	65.7 (1669)			2	8	8	2080 (943)
☐ 2506	2499 (732.4)	2404 (704.5)	9 to 1	96.2	78 (1981)	34 (864)	60 (1524)	70.4 (1788)	13-1/8 (333)	13-1/2 (343)	2-1/2	10	8	2900 (1315)
☐ 3006	3000 (879.2)	2865 (839.4)	10 to 1	95.5	78 (1981)	34 (864)	60 (1524)	70.4 (1788)			2-1/2	10	8	2900 (1315)

	☐ 856		☐ 1006		☐ 1256		☐ 1506		☐ 1756		☐ 2006		☐ 2506		☐ 3006	
	GPM (L/min)	ΔP ft.hd. (kPa)	GPM (L/min)	ΔP ft.hd. (kPa)	GPM (L/min)	ΔP ft.hd. (kPa)	GPM (L/min)	ΔP ft.hd. (kPa)	GPM (L/min)	ΔP ft.hd. (kPa)	GPM (L/min)	ΔP ft.hd. (kPa)	GPM (L/min)	ΔP ft.hd. (kPa)	GPM (L/min)	ΔP ft.hd. (kPa)
20 FAT	82 (310)	1.7 (5.1)	96 (363)	2.2 (6.6)	120 (454)	2.6 (7.8)	144 (545)	3.6 (10.8)	168 (636)	3.8 (11.4)	192 (727)	4.7 (14.0)	**231 (874)	7.1 (21.2)	**231 (874)	7.1 (21.2)
40 FAT	41 (155)	0.5 (1.5)	48 (182)	.7 (2.1)	60 (227)	.8 (2.4)	72 (273)	.9 (2.7)	84 (318)	1.0 (3.0)	96 (363)	1.2 (3.6)	120 (454)	2.1 (6.3)	143 (541)	3.0 (8.9)
**Max Flow	165 (624)	6.4 (19.1)	192 (727)	7.8 (23.3)	231 (874)	8.0 (23.9)	231 (874)	8.0 (23.9)	231 (874)	6.7 (20.0)	231 (874)	6.7 (20.0)	231 (874)	7.1 (21.2)	231 (874)	7.1 (21.2)
*Min Flow at 100%	22 (83)		24 (91)		30 (114)		36 (136)		42 (159)		48 (182)		60 (227)		72 (273)	
*Min Flow for Ignition	22 (83)		22 (83)		22 (83)		22 (83)		25 (95)		30 (114)		40 (151)		45 (170)	
*Min Flow	22 (83)		22 (83)		22 (83)		22 (83)		22 (83)		22 (83)		22 (83)		29 (110)	

*Minimum flow based on water as heating medium. Mediums other than water may require higher minimum flow rates.
 **Maximum flow based on 10 FAT or 10.5 feet per second velocity, whichever is less.

Model	Power Supply	Amp Draw**
☐ 0856	120V/1PH	Less Than 12A
☐ 1006		
☐ 1256		
☐ 1506		
☐ 1756	208V/1PH	Less Than 18A
☐ 2006		
☐ 2506		
☐ 3006		

Standard Power Shown.
 ** Current draw is for boiler only
 Optional: 208/230/277V/3PH or 480/600V/3PH
 Consult factory for current draw information.

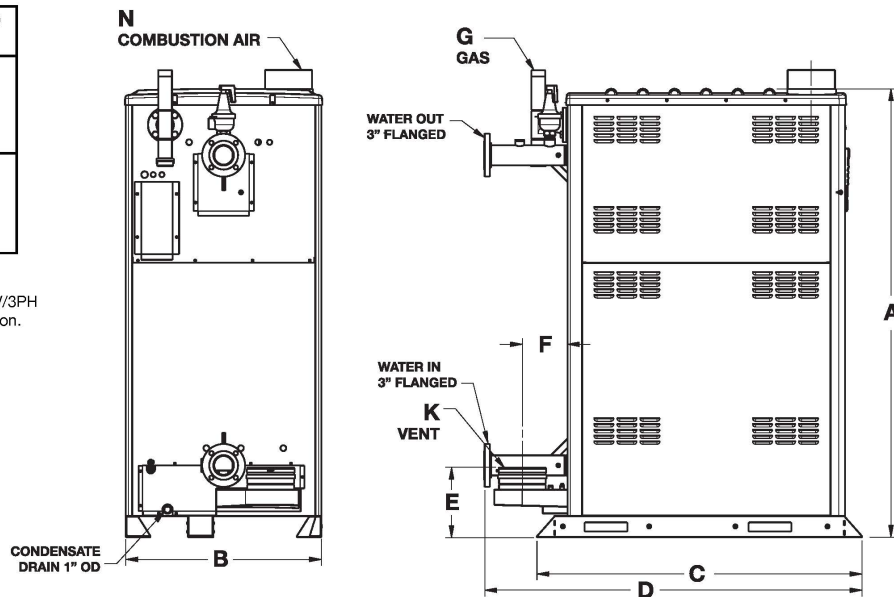

www.raypak.com

2151 Eastman Avenue | Oxnard, CA 93030 | 805-278-5300