

# ENERGY PLUS COMMERCIAL WASHER



Featuring Factory-Installed Coin Slide and Coin Box



2013 Department of Energy Compliant  
Modified Energy Factor: 1.85

Water Factor: 6.85

On average, uses 20 gallons per cycle—the  
lowest water consumption for Whirlpool®  
Commercial top-load washers.

## FOR YOUR CUSTOMERS

- Large Capacity Wash Basket is Ideal for Family-Size Loads
- Proven Cleaning Performance
- Extra-Large Lid and Tub Opening
- 3 Cycle Options: Normal, Permanent Press and Delicates for a Wide Range of Fabrics
- Separate Temperature Controls
- Ergonomic Control Knobs

## AUTOMATIC LOAD SENSING

Adjusts water fill level based on load size, reducing water usage by up to 18 gallons per wash cycle.

## BALANCE RING ADAPTER—CLOTHES GUARD

Discourages overloading and keeps small items out of the pump.

## SECURE LID SYSTEM WITH SAFE RELEASE

To help ensure safe operation, the lid locks at start of cycle. Prevents damage when forced open.

## INDUSTRIAL STRENGTH WATER INLET HOSES

- Tested to 1100 PSI
- Extra-long 6' Hoses



## CAE2743BQ—27" Commercial Washer

- 2.9-Cu.-Ft. Wash Basket
- Energy Plus, Low Water Factor
- 3 Cycles: Normal, Permanent Press, Delicates
- Cycle Indicator LEDs
- Powdered Paint Top and Lid, Rustproof Stainless Steel Torx® Control Panel Screws
- Galvanized, Heavy-Gauge Cabinet Back, Side and Front Panel
- High-Speed Spin—700 RPM (maximum)
- 1/3 HP Motor
- Factory Coin Slide and Coin Box Equipped, \$1.50 Factory Preset Vend V8 Coin Slide
- Onboard Self Diagnostics
- Easy Adjustable Legs
- **90-Day Labor/2-Year Limited Parts Only Warranty\***

\*Call 1-800-662-3587 for warranty details.

# ENERGY PLUS COMMERCIAL WASHER



Featuring Factory-Installed Coin Slide and Coin Box

## Whirlpool® Energy Plus Commercial Washer Factory-Installed Coin Slide and Coin Box

WASHER SPECIFICATIONS	
<b>MODEL</b>	CAE2743BQ
<b>GENERAL INFORMATION</b>	
Modern design and look with all metal console and ergonomic control knobs. Automatic lid lock feature.	Large Capacity 2.9-Cu.-Ft. Basket
<b>BASKET VOLUME</b>	2.9 Cu. Ft.
<b>MOTOR</b>	
120 Volt, 1/3 HP, 1/4 kw, with thermal overload protection	Single-speed, permanent split capacitor, reversible motor
Spin RPM—Maximum	700
<b>MAXIMUM RATED CURRENT—AMPS (VOLT)</b>	8 (120)
<b>ELECTRICAL REQUIREMENTS</b>	120V, 60 Hz
Breaker/Fuse—AMPS	15
<b>SHIPPING WEIGHT (EST.)</b>	152 Lbs. Crated, 136 Lbs. Uncrated
<b>DIMENSIONS</b>	
Cabinet Width—in. (mm)	27 (686)
Cabinet Depth—in. (mm)	25.5 (648)
Cabinet Height—in. (mm) at Metercase Top	43 (1092)

Dimensions are for planning purposes only. For complete information, see installation instructions packed with product.

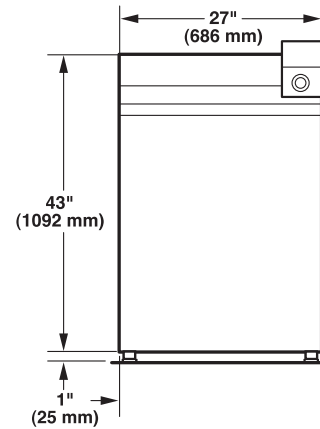

WASHER FRONT VIEW

NEW YORK CITY  
M.E.A.

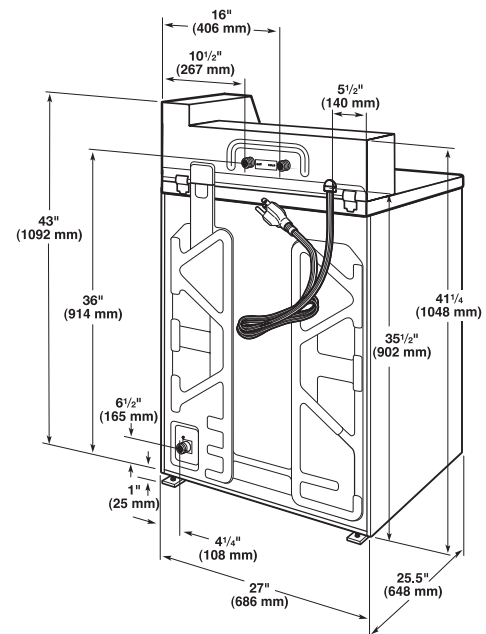

WASHER BACK VIEW



To Locate a Distributor Near You, Please Visit [www.whirlpoolcommerciallaundry.com/distributor](http://www.whirlpoolcommerciallaundry.com/distributor), or call 1-800-662-3587.