

WIRING SCHEMATIC

SCHEMATIC
 NOTE: CONDITION OF OVEN
 1. Door Closed
 2. CLOCK APPEARS ON DISPLAY

Note: * Indicates component

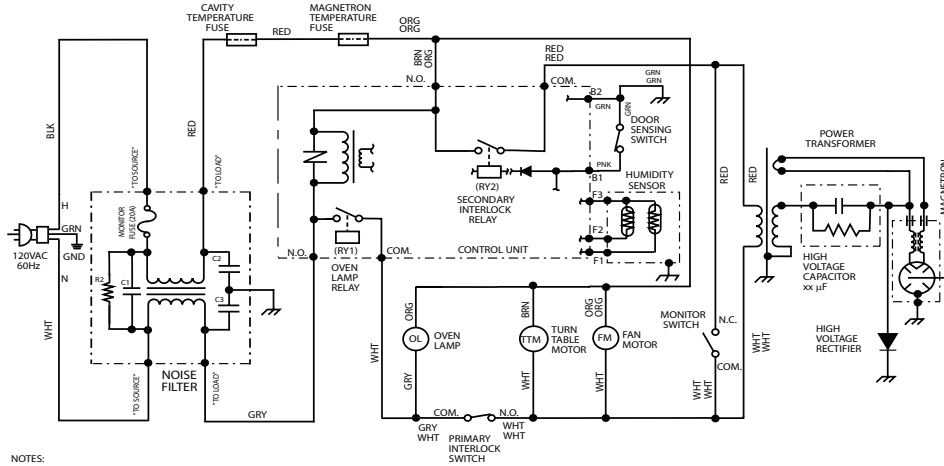

- NOTES:
 1. CIRCUITS SUBJECT TO CHANGE WITHOUT NOTICE.
 2. TERMINAL WITH PROJECTION OR OPPOSITE BLUE MARK ON LAMP SOCKET MUST BE CONNECTED TO NEUTRAL WIRE.
 3. ONLY CERTAIN MODELS USE THE ABSOLUTE HUMIDITY SENSOR.
 4. POWER TRANSFORMER TOP (FINISH LEAD) TERMINAL MUST BE CONNECTED TO THE NEUTRAL (WHT) WIRE.

Figure O-1 Oven Schematic - Off Condition

SCHEMATIC
 NOTE: CONDITION OF OVEN
 1. DOOR CLOSED
 2. COOKING TIME PROGRAMMED
 3. VARIABLE COOKING CONTROL "HIGH"
 4. "START" PAD TOUCHED

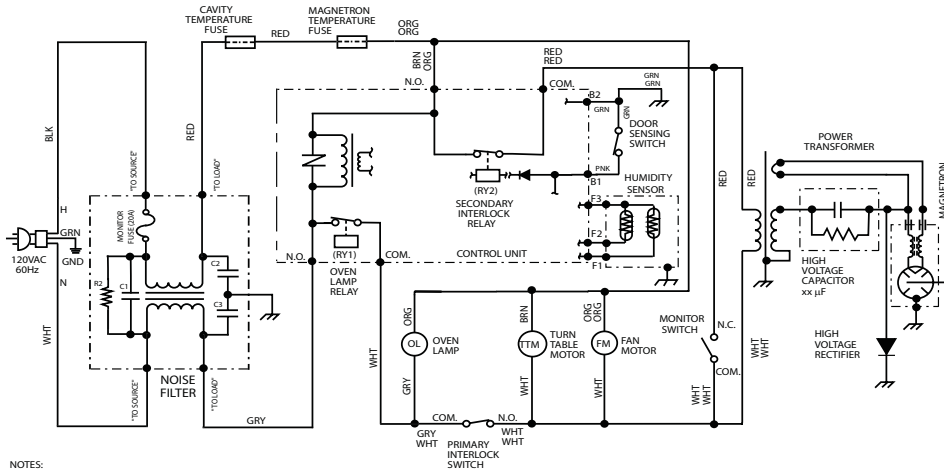

- NOTES:
 1. CIRCUITS SUBJECT TO CHANGE WITHOUT NOTICE.
 2. TERMINAL WITH PROJECTION OR OPPOSITE BLUE MARK ON LAMP SOCKET MUST BE CONNECTED TO NEUTRAL WIRE.
 3. ONLY CERTAIN MODELS USE THE ABSOLUTE HUMIDITY SENSOR.
 4. POWER TRANSFORMER TOP (FINISH LEAD) TERMINAL MUST BE CONNECTED TO THE NEUTRAL (WHT) WIRE.

Figure O-2 Oven Schematic - Cooking Condition