

MiniFogger

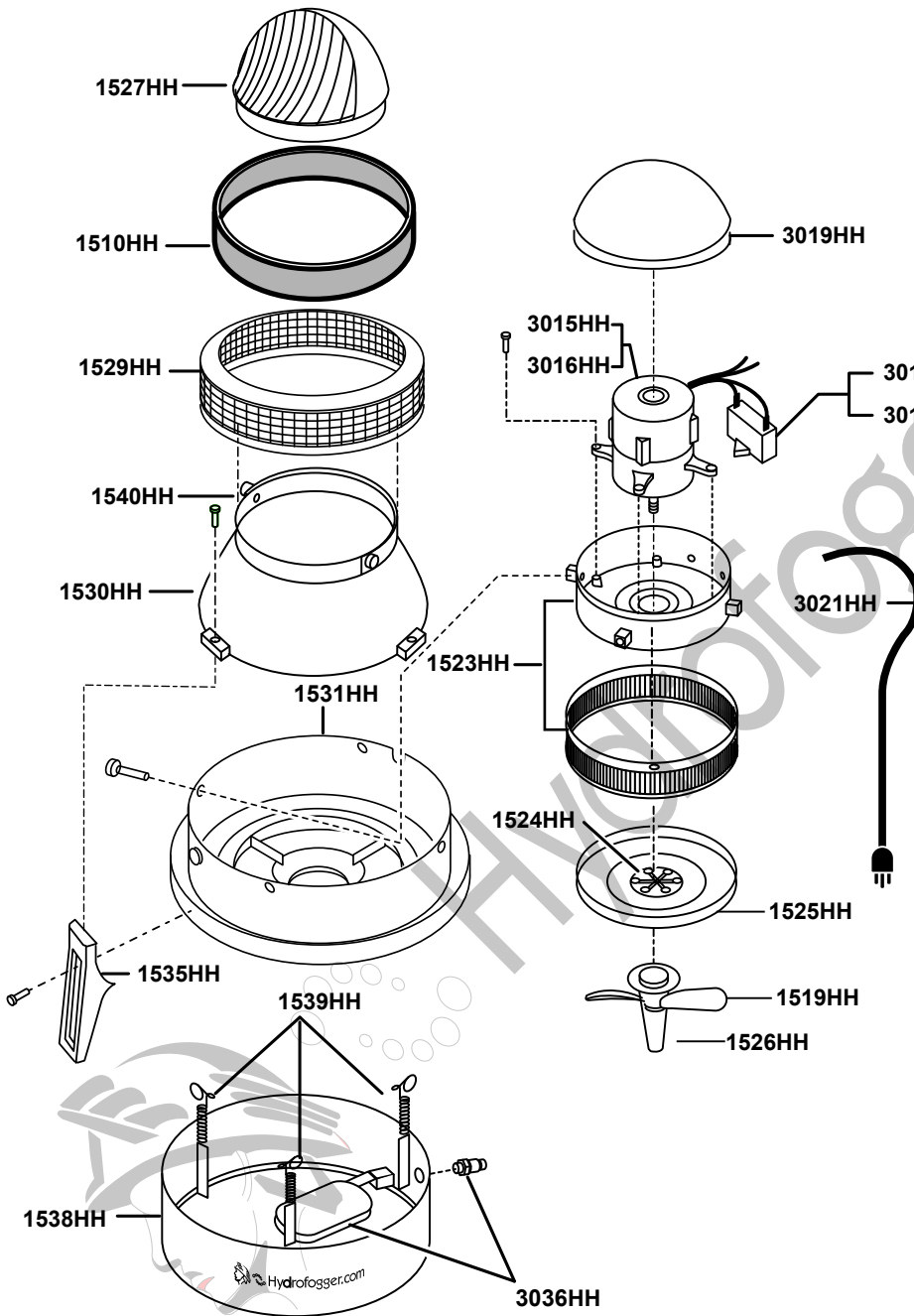

| PART# | DESCRIPTION | QTY |
|--------|--------------------------------------|-----|
| 3015HH | MOTOR (115V/60Hz) North American | 1 |
| 3016HH | MOTOR (230V/50Hz) Foreign | 1 |
| 3017HH | CAPACITOR (115V/60Hz) North American | 1 |
| 3018HH | CAPACITOR (230V/50Hz) Foreign | 1 |
| 1519HH | FAN BLADE | 1 |
| 3019HH | MOTOR COVER | 1 |
| 3021HH | CORD | 1 |
| 1510HH | AIR FILTER | 1 |
| 1523HH | ATOMIZING SCREEN + MOTOR SUPPORT | 1 |
| 1524HH | HUB ASSEMBLY | 1 |
| 1525HH | DISK | 2 |
| 1526HH | PUMP | 1 |
| 1527HH | FOGGING HEAD | 1 |
| 1529HH | SCREEN | 1 |
| 1530HH | HOUSING | 1 |
| 1531HH | MID PAN | 1 |
| 1532HH | LOWER PAN | 1 |
| 1535HH | LEG | 3 |
| 3036HH | FLOAT VALVE KIT | 1 |
| 1538HH | RESERVOIR PAN | 1 |
| 1539HH | SPRING | 3 |
| 1540HH | HANDLE | 1 |