

INSTALLATION & OPERATING INSTRUCTIONS

Raytherm[®] Heating Boilers



**Models 0181-4001
Type H**



WARNING: Improper installation, adjustment, alteration, service or maintenance can cause property damage, personal injury or loss of life. Refer to this manual. Installation and service must be performed by a qualified installer, service agency or the gas supplier.

FOR YOUR SAFETY: Do not store or use gasoline or other flammable vapors and liquids or other combustible materials in the vicinity of this or any other appliance. To do so may result in an explosion or fire.

WHAT TO DO IF YOU SMELL GAS:

- Do not try to light any appliance.
- Do not touch any electrical switch; do not use any phone in your building.
- Immediately call your gas supplier from a neighbor's phone. Follow the gas supplier's instructions.
- If you cannot reach your gas supplier, call the fire department.

Installation and service must be performed by a qualified installer, service agency or the gas supplier.

This manual should be maintained in legible condition and kept adjacent to the heater or in a safe place for future reference.

Raypak[®]
A Rheem[®] Company

Rev. 38 reflects the following:

Changes to:

Additions:

Deletions:

CONTENTS

WARNINGS	4	ELECTRICAL CONNECTIONS	25
Pay Attention to These Terms	4	START-UP	26
MODEL IDENTIFICATION	5	Before Start-Up	26
RECEIVING EQUIPMENT	6	General	26
CERTIFICATIONS	6	Filling System - Heating Boilers	26
BOILER TYPES	6	Ethylene Glycol Systems -	
Type H1 - Mechanical Modulating	6	Heating Boilers	26
Type H2 - Motorized Modulating	6	Initial Start-Up - Pump And Motor	26
Type H3 - 2-Stage Controls	6	For Models with Automatic Gas Valves	28
Type H4 - On-Off Controls	6	After Start-Up	28
Type H5 - Mechanical Modulating	6	Intermittent Pilot System IID	28
Type H9 - 4-Stage	6	Inspections	28
INSTALLATION	6	Burners	28
Installation Codes	6	Controls	29
Installation Base	7	Suggested Inspection Schedule	29
Clearances	7	LOW NOx BOILERS	30
Outdoor Boilers	8	Models 0181 to 0401	30
High-Wind Conditions		Operation	30
(Outdoor Units Only)	8	Start-Up IID	30
Combustion and Ventilation Air		Blower Adjustment	30
(Indoor Units Only)	8	Visual Inspection	30
Venting	9	Electrical	30
Indoor Installations	10	Flame Roll-Out Safety Switch	31
Vent Piping	12	Service	31
Vent Damper Installation	14	Burner Tray Removal	31
Plumbing	15	Gas Valve Adjustment	31
Gas Supply Connections	15	Gas Valve Removal	32
CONTROLS	20	Main Burner and Orifice Removal	32
Economaster Controls	20	Pilot Removal	32
Electronic Ignition	20	Combustion Fan Removal	32
Outdoor Air Reset Temperature		TROUBLESHOOTING	33
Controller	20	Service	37
Operating Controls	22	Repair Section	37
Limit Controls	24	REPLACEMENT PARTS	40
		WARRANTY	41

WARNINGS—Pay Attention to These Terms

DANGER:	Indicates the presence of immediate hazards which will cause severe personal injury, death or substantial property damage if ignored.
WARNING:	Indicates the presence of hazards or unsafe practices which could cause severe personal injury, death or substantial property damage if ignored.
CAUTION:	Indicates the presence of hazards or unsafe practices which could cause minor personal injury or product or property damage if ignored.
NOTE:	Indicates special instructions on installation, operation, or maintenance which are important but not related to personal injury hazards.

DANGER: Make sure the gas on which the heater will operate is the same type as that specified on the heater rating plate.

WARNING: Should overheating occur or the gas supply valve fail to shut, do not turn off or disconnect the electrical supply to the heater. Instead, shut off the gas supply at a location external to the heater.

WARNING: Do not use this heater if any part has been under water. Immediately call a qualified service technician to inspect the heater and to replace any part of the control system and any gas control which has been under water.

WARNING: This unit contains refractory ceramic fiber (RCF) insulation in the combustion chamber. RCF, as manufactured, does not contain respirable crystalline silica. However, following sustained exposure to very high temperatures (>2192F), the RCF can transform into crystalline silica (cristabolite). The International Agency for Research on Cancer (IARC) has classified the inhalation of crystalline silica (cristabolite) as carcinogenic to humans.

When removing the burners or heat exchangers, take precautions to avoid creating airborne dust and avoid inhaling airborne fibers. When cleaning spills, use wet sweeping or High Efficiency Particulate Air (HEPA) filtered vacuum to minimize airborne dust. Use feasible engineering controls such as local exhaust ventilation or dust collecting systems to minimize airborne dust. Wear appropriate personal protective equipment including gloves, safety glasses with side shields, and appropriate NIOSH certified respiratory protection, to avoid inhalation of airborne dust and airborne fiber particles.

WARNING - CALIFORNIA PROPOSITION 65: This product contains chemicals known to the State of California to cause cancer, birth defects or other reproductive harm.

WARNING: To minimize the possibility of improper operation, serious personal injury, fire, or damage to the heater:

- Always keep the area around the heater free of combustible materials, gasoline, and other flammable liquids and vapors.
- Heater should never be covered or have any blockage to the flow of fresh air to the heater.

WARNING: Risk of electrical shock. More than one disconnect switch may be required to de-energize the equipment before servicing.

CAUTION: Operation of this heater in low temperature systems requires special piping. Harmful internal condensation will occur if the inlet water temperature does not exceed 105°F. Warranty claims will be denied when condensation occurs.



CAUTION: If this heater is to be installed above radiation level, it must be provided with a low water cut-off device at the time of heater installation.

CAUTION: This heater requires forced water circulation when the burner is operating. See minimum and maximum flow rates. Severe damage will occur if the heater is operated without proper water flow circulation.

CAUTION: If this heater is to be installed in a negative or positive pressure equipment room, there are special installation requirements. Consult factory for details.

MODEL IDENTIFICATION

The model number of a boiler can be found on the Sales Order and the boiler's rating plate. The example below identifies what the characters of the model number represent.

 NATL. BD. <input type="text"/> CERTIFIED BY RAYPAK, INC. OXNARD, CALIFORNIA H MAX W.P. WATER 160 PSI BTU/HR.INPUT <input type="text"/> MFR.SERIAL NO. <input type="text"/> MIN RELIEF VALVE CAP <input type="text"/> LBS/HR HEATING SURFACE <input type="text"/> SQ.FT. BOILER HEATING SURFACE <input type="text"/> SQ.FT. EXTENDED HEATING SURFACE <input type="text"/> SQ.FT. WATERWALL MAX WATER TEMP 250F	HOT WATER BOILER		FOR INSTALLATION ON NON-COMBUSTIBLE FLOORS ONLY* *FOR INSTALLATION ON COMBUSTIBLE FLOORING ONLY WHEN INSTALLED ON SPECIAL BASE PART NUMBER
	MIN. CLEARANCES FROM COMBUSTIBLE CONSTRUCTION RIGHT SIDE LEFT SIDE BACK TOP	MODEL PART NO. MODEL PART NO.	FOR SERVICING, PROVIDE AT LEAST OF UN- OBSTRUCTED CLEARANCE IN FRONT OF UNIT.
BTU/HR.OUTPUT <input type="text"/> <input type="text"/> BTU/HR.INPUT <input type="text"/> MIN INPUT RATE <input type="text"/> BTU/HR. GAS <input type="text"/> MODEL NO. <input type="text"/> CATEGORY 1 BOILER ACCEPTED FOR USE CITY OF NEW YORK DEPARTMENT OF BUILDINGS MEA NO. <input type="text"/> DADE COUNTY PRODUCT CONTROL APPROVED LOW PRESSURE BOILER P/N 900808	MAX. PERMISSIBLE GAS SUPPLY PRESSURE NAT 14" W.C. LPG 14" W.C. MIN. PERMISSIBLE GAS SUPPLY PRESSURE FOR PURPOSE OF INPUT ADJUSTMENT 7" W.C. 12" W.C. MANIFOLD PRESSURE 4" W.C. 11" W.C.		
ELECTRICAL RATING: 120/24V 60 HZ. LESS THAN 12 AMPERES			

Boiler rating plate showing model number

MODEL NUMBER EXAMPLE:

H 3 - 0 5 1 4 A

- Series**
- Model Size**
Representative of approximate MBTUH input
(Model 0514 has input of 511,500 BTUH)
- Firing Mode**
 - 1 Mechanical Modulation
 - 2 Motorized Modulation
 - 3 2-Stage Firing
 - 4 On-Off Firing
 - 5 Low Temperature Mechanical Modulation
 - 9 4-Stage Firing
- Application**
H = Heating Boiler

RECEIVING EQUIPMENT

On receipt of the equipment, visually check for external damage to the carton or the shipping crate. If either is damaged, make a note on the Bill of Lading and report the damage to the Carrier immediately. Remove the boiler from the carton or the shipping crate.

On occasion, items are shipped loose. Be sure that you receive the number of packages indicated on the Bill of Lading.

When ordering parts, you must specify the Model and Serial Number of the boiler. When ordering under warranty conditions, you must also specify the date of installation.

Raypak recommends that this manual be reviewed thoroughly before installing your Raypak boiler. If there are any questions which this manual does not answer, please contact the factory or your local Raypak representative.

Claims for shortages and damages must be filed with carrier by consignee. Permission to return goods must be factory authorized and are subject to a stocking charge.

Purchased parts are subject to replacement only under the manufacturer's warranty. Debits for defective replacement parts will not be accepted and will be replaced in kind only per our standard warranties.

CERTIFICATIONS

The Raypak hydronic boilers are design-certified and tested under the latest requirements of the American National Standard, ANSI Z21.13. Each boiler has been constructed and pressure tested in accordance with the requirements of Section IV Part H of the American Society of Mechanical Engineers Code, and factory fire-tested.

All models are National Board registered. Temperature and pressure gauge is standard. Models 0181-1826 have 2-pass heat exchangers, 5 tubes first pass, 4 tubes second pass. Models 2100-4001 have 2-pass heat exchangers, 9 tubes per pass. Models 0926-4001 with cast-iron headers allow optional single-pass heat exchangers.

All units are CSA-certified for low-lead content (<.25%).

Minimum water temp of 105F at the inlet.

BOILER TYPES

Type H1 - Mechanical Modulating, Models 0514-1826

Central heating boiler with 150°-210°F mechanical modulating gas valve(s). The number of valves varies with the model size.

Type H2 - Motorized Modulating, Models 0514-4001

Central heating boiler with a motorized modulating gas valve. Modulating controller optional.

Type H3 - 2-Stage Controls, Models 0181-4001

Central heating boiler with single 2-stage gas valve and optional 2-stage controller. Outdoor Air Reset controller standard on models 0181-0261.

Type H4 - On-Off Controls, Models 0181-4001

Central heating boiler with on-off firing. Outdoor Air Reset controller standard on models 0181-0261.

Type H5 - Mechanical Modulating, Models 0514-1826

Central heating boiler with 110°-170°F mechanical modulating gas valve(s). The number of valves varies with the model size.

Type H9 - 4-Stage, Models 0514-4001

Central heating boiler with 4-stage firing. Controller optional.

INSTALLATION

Installation Codes

The installation must conform with these instructions and the latest editions of the National Fuel Gas Code ANSI Z223.1, the National Electric Code ANSI/NFPA 70 and local codes. In Canada installations must conform with the current CAN/CSA B149 and the Canadian Electrical Code CSA C22.1 C.E.C. Part 1 (C22.1). All boiler installations must conform to ASME boiler code. Hot water pipes must be installed with minimum clearances to combustible material as required by code.

Installation Base

The boiler should be mounted on a level, non-combustible surface. Boiler must not be installed on carpeting. The boiler can be installed on a combustible surface only when a suitable floor shield base is provided. Raypak offers an optional floor shield base which can be factory installed on all indoor models. Do NOT use the shipping crate base as an installation base.

NOTE: For Models 2100-4001, a factory-installed floor shield is standard. Table B provides the floor shield ordering information for other models.

NOTE: The boiler should be located in an area where water leakage will not result in damage to the area adjacent to the appliance or to the structure. When such locations cannot be avoided, it is recommended that a suitable drain pan, adequately drained, be installed under the appliance. The pan must not restrict air flow.

In addition, the boiler shall be installed such that the gas ignition system components are protected from water (dripping, spraying, rain, etc.) during appliance operation and service (circulator replacement, control replacement, etc.).

Boiler Model No.	Base Part No.	Boiler Model No.	Base Part No.
0182/ 0181	058313	0926*	054597
0260/ 0261	058314	1083*	054598
0330/ 0331	058315	1178*	054599
0400/ 0401	058316	1287*	054600
		1414*	054601
		1571*	058378
		1758*	058379
0514	056199	0962	059233
0624	056200	1125	059234
0724	056201	1223	059235
0824	056202	1336	059236
		1468	059237
		1631	059238
		1826	059239

* Models with factory-installed floor shield as standard.
BOLD type indicates Low NOx models.

Table B: Combustible Floor Shield Ordering Information

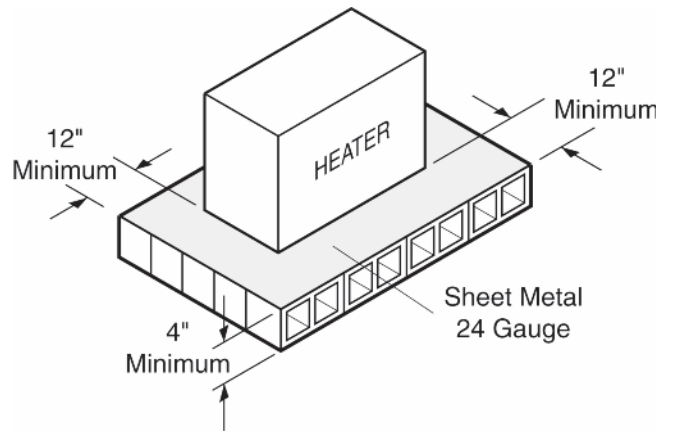

Fig. 2: Alternate Method for Providing a Non-Combustible Base

Clearances

Location	Model			
	0181 to 0401	0514 to 0824	0926 to 1826	2100 to 4001
Floor	See Note 1			
Front	See Note 2			
Back	12	12	24	24
Right	12	6	24	24
Left	12	18	24	24
*Vent	6	6	6	6
Indoor Top	39	36	24	24
Outdoor Top	Unobstructed			NA

All dimensions are in inches.

Derived from National Fuel Gas Code, Table 6.2.3(a)

*Vent includes factory-supplied draft hood and does not include field-supplied vent systems above the draft hood. On Models 2100-4001 draft hood is built into boiler.

Table C: Clearances from Combustible Surfaces

NOTE 1: Combustible floor shield is required when boiler is to be installed on a combustible surface. (See ordering information in Table B.)

NOTE 2: Servicing Clearances: Provide at least 24" (Models 0181-1826), 48" (Models 2100-4001) in front of unit for removal and servicing of the Controls & Burner Tray. Provide at least 18" on side opposite water connections for delimiting of Heat Exchanger Tubes.

NOTE: The boiler shall be installed in a space large in comparison to the size of the boiler. Large space is defined as having a volume at least sixteen (16) times the total volume of the boiler.

Description	Location	Boiler Size			
		0181 to 0401	0514 to 0824	0926 to 1826	2100 to 4001
a. 3-1/2 in. thick masonry walls without ventilated air space.	Back	9	9	16	16
	Right	9	5	16	16
	Left	9	12	16	16
	Vent	5	5	5	5
	Indoor Top	39	36	24	24
	Outdoor Top	Unobstructed			
b. 1/2 in. insulation board over 1 in. glass fiber or mineral wool batts.	Back	6	6	12	12
	Right	6	3	12	12
	Left	6	9	12	12
	Vent	3	3	3	3
	Indoor Top	30	24	16	16
	Outdoor Top	Unobstructed			
c. 0.024 sheet metal over 1 in. glass fiber or mineral wool batts reinforced with wire on rear face with ventilated air space.	Back	4	4	8	8
	Right	4	3	8	8
	Left	4	6	8	8
	Vent	3	3	3	3
	Indoor Top	24	18	12	12
	Outdoor Top	Unobstructed			
d. 3-1/2 in. thick masonry wall with ventilated air space.	Back	6	6	8	8
	Right	6	6	8	8
	Left	6	6	8	8
	Vent	6	6	6	6
	Indoor Top	39	36	24	24
	Outdoor Top	Unobstructed			
e. 0.024 sheet metal with ventilated air space.	Back	4	4	8	8
	Right	4	2	8	8
	Left	4	6	8	8
	Vent	2	2	2	2
	Indoor Top	24	18	12	12
	Outdoor Top	Unobstructed			
f. 1/2 in. thick insulation board with ventilated air space.	Back	4	4	8	8
	Right	4	3	8	8
	Left	4	6	8	8
	Vent	3	3	3	3
	Indoor Top	24	18	12	12
	Outdoor Top	Unobstructed			
g. 0.024 sheet metal with ventilated air space over 0.024 sheet metal with ventilated air space.	Back	4	4	8	8
	Right	4	3	8	8
	Left	4	6	8	8
	Vent	3	3	3	3
	Indoor Top	24	18	12	12
	Outdoor Top	Unobstructed			
h. 1 in. glass fiber or mineral wool batts sandwiched between two sheets 0.024 sheet metal with ventilated air space.	Back	4	4	8	8
	Right	4	3	8	8
	Left	4	6	8	8
	Vent	3	3	3	3
	Indoor Top	24	18	12	12
	Outdoor Top	Unobstructed			

Derived from National Fuel Gas Code, Table 10.2.3

Table D: Reduction of Clearances to Protected Surfaces

Outdoor Boilers

These boilers are design-certified for outdoor installation. Boilers must not be installed under an overhang within three (3) feet from the top on the boiler. Three (3) sides must be open in the area under the overhang. Roof water drainage must be diverted away from the boilers with the use of gutters.

The point from where the flue products exit the boiler must be a minimum of four (4) feet below, four (4) feet horizontally from or one (1) foot above any door, window or gravity inlet to a building. The top surface of the boiler shall be at least three (3) feet above any forced air inlet, or intake ducts located within ten (10) feet horizontally.

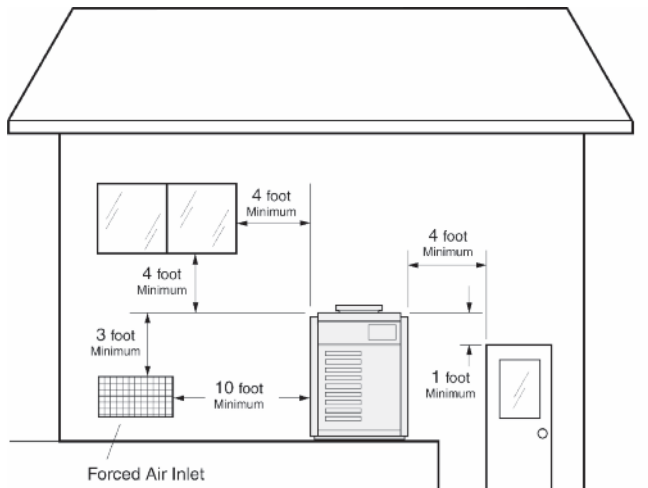

Fig. 3: Minimum Distances to Building Openings from Where Flue Products Exit the Boiler

High-Wind Conditions (Outdoor Units Only)

In areas where high winds are frequent, it may be necessary to locate the boiler a minimum of 3' from high vertical walls, or install a wind break so the boiler is not in direct wind current.

Combustion and Ventilation Air (Indoor Units Only)

The boiler must have both combustion and ventilation air. Minimum requirements for net free air supply openings are 12 inches from ceiling for ventilation and 12 inches from the floor for combustion air as outlined in Z223.1 - latest edition or the current CAN/CSA B149, as well as any local codes that may have jurisdiction.

CAUTION: Combustion air must not be contaminated by corrosive chemical fumes which can damage the boiler and void the warranty.

- a. All Air From Inside The Building:
Each opening shall have a minimum net free square inches as noted in Table E.

Model	Sq. Inches	Model	Sq. Inches
0182/0181	181	1223	1223
0260/0261	264	1336	1337
0330/0331	334	1468	1467
0400/0401	399	1631	1630
0514	512	1826	1826
0624	627	2100	2100
0724	726	2500	2499
0824	825	3001	3000
0962	962	3500	3500
1125	1125	4001	4000

Table E: Minimum Net Free Air from Inside Building

- b. All Air From Outdoors:
When air is supplied directly from outside of building, each opening shall have a minimum net free square inches as noted in Table F.

Model	Sq. Inches	Model	Sq. Inches
0182/0181	46	1223	306
0260/0261	66	1336	335
0330/0331	84	1468	367
0400/0401	100	1631	408
0514	128	1826	457
0624	157	2100	525
0724	182	2500	625
0824	207	3001	750
0962	241	3500	875
1125	282	4001	1000

Table F: Minimum Net Free Air from Outside Building

Venting

Outdoor Installations

Models 0181-0401 & 0182-0400

Outdoor Top Installation

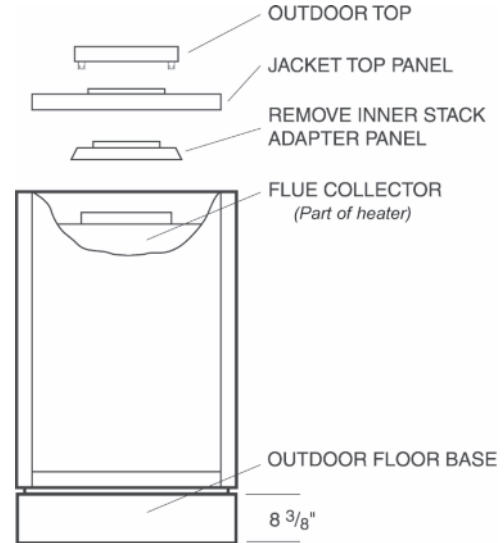

Fig. 4: Installing Outdoor Top—Models 0181-0401 & 0182-0400

1. Remove jacket top panel.
2. Remove and discard inner stack adapter panel.
3. Install jacket top panel.
4. Insert tabs of outdoor top into keyholes located on jacket top panel (4 places). See Detail A.
5. Snap tabs on outdoor top into the locked position of the keyhole so the top will not pull out. See Detail B.

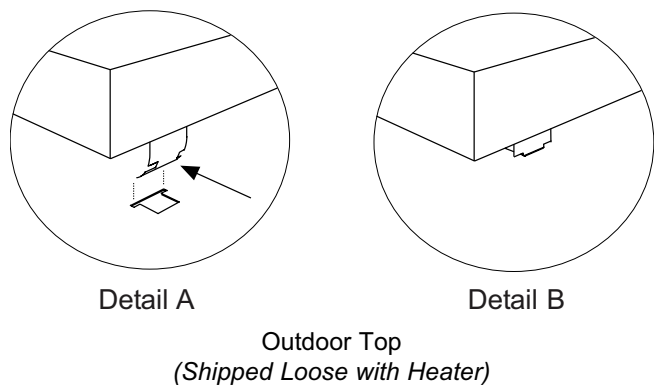

Fig. 5: Installing Outdoor Top—Models 0181-0401 & 0182-0400

Models 0514-0824

1. Lower outdoor top onto unit. Position top so it is centered on unit from side to side and front to rear.

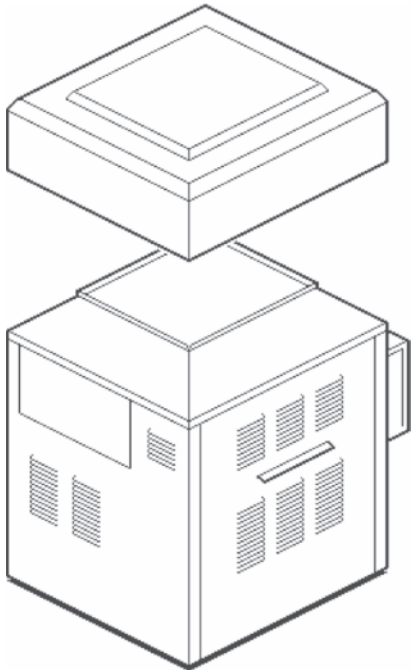

Fig. 6: Installing Outdoor Top—Models 0514–0824

2. Tighten the (4) screws (as indicated in Fig. 7) until they come in contact with the unit jacket top, then evenly tighten all (4) screws to secure to unit.

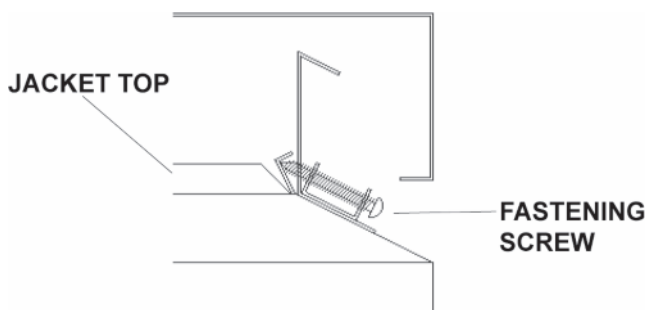

Fig. 7: Installing Outdoor Top Detail—Models 0514–0824

Models 0926-1758

Boilers are shipped with outdoor vent terminal factory installed.

Indoor Installations

Models 0181-0401 & 0182-0400

Indoor Stack Installation

1. Remove the louvered jacket top by removing four (4) #10 flathead screws.
2. If originally installed, remove outdoor top from the louvered jacket top.
3. Place the inner stack adapter panel over the flue collector inside the heater. Make sure the flanged side of the flue opening is up.
4. Turn the stack (draft hood) upside down and set it down bottom side up.
5. Turn the jacket top panel (removed in step 1) upside down and place it over the stack.
6. Attach the three (3) mounting brackets to the stack using the screws provided and the holes that are pre-drilled in the stack. **Make sure the brackets are positioned with the flange near the top side of the stack (see Fig. 8). Caution must be taken not to over tighten and strip the screw threads.**
7. Turn the assembled stack and jacket top, rightside up. The jacket top will be trapped between the brackets and the top of the stack. Place the stack over the inner stack adapter panel flanged hole and lower the louvered jacket top panel back into its original position. Reinstall the four (4) #10 flat-head screws removed in step 1 above.

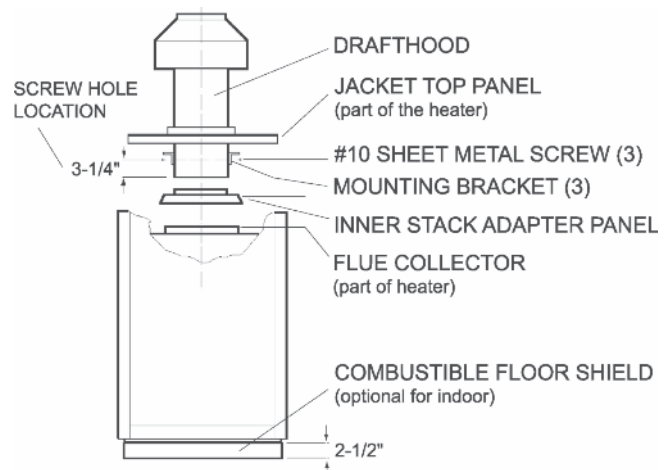

Fig. 8: Indoor Installation—Models 0181-0401 & 0182-0400

Models 0181-0401 & 0182-0400

1. Shut-off main electrical power switch to boiler.
2. Turn heater manual switch located in upper control panel to the "OFF" position.
3. Shut-off gas supply and water supply to the boiler.
4. Mount drafthood on top of boiler as shown in Fig. 10. Drafthood should be positioned with the vent sensor located on the front right side as shown.
5. Remove plastic plug from left side of boiler jacket and install plastic grommet provided.
6. Route flue sensor wire harness through the grommet installed in Step 5 (Models 0181-0261).
7. Remove door and locate wire from roll-out sensor to high limit with the male/female connector.
8. Disconnect male/female connector and attach to the 2 wires from drafthood vent sensor harness.

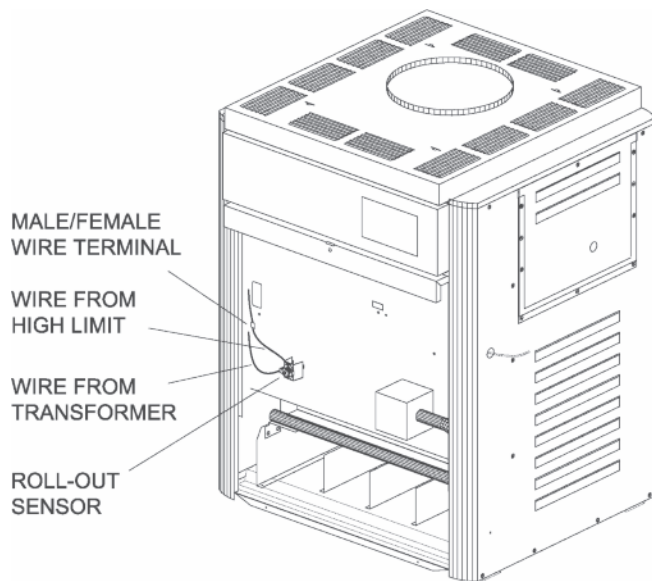

Fig. 9: Boiler Before Drafthood Installation—Models 0181-0401 & 0182-0400

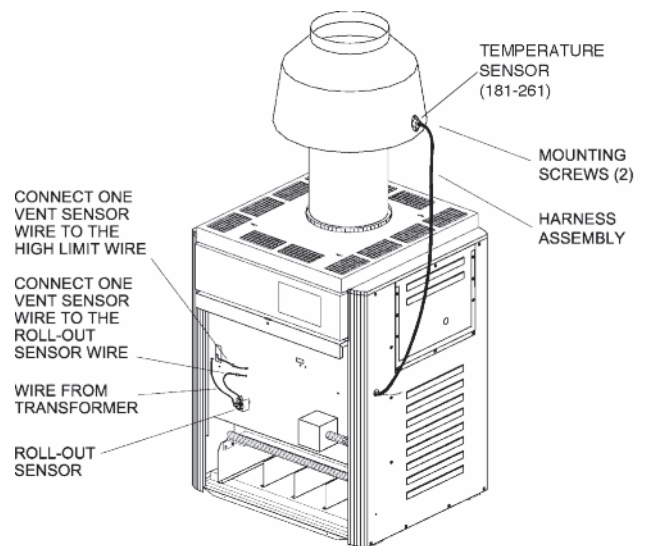

Fig. 10: Boiler After Drafthood Installation—Models 0181-0401 & 0182-0400

Models 0514-0824

Locate and assemble as shown in Fig. 11. Secure with screws supplied in envelope in carton.

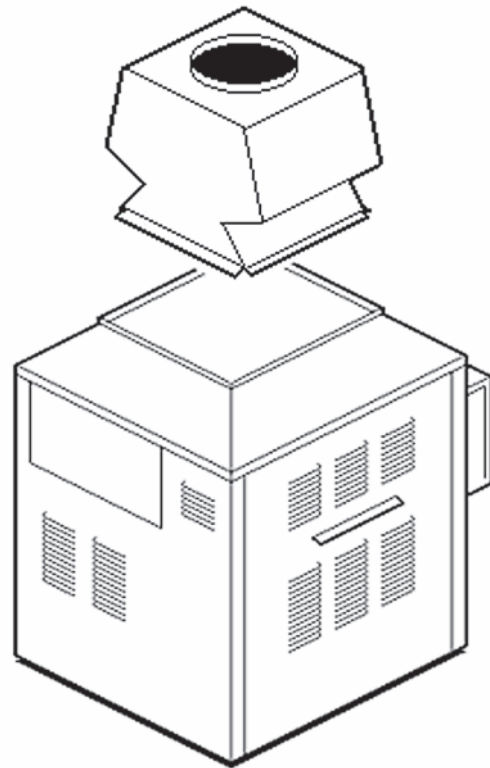

Fig. 11: Drafthood Installation—Models 0514-0824

Models 0962-1826

Locate and assemble as shown in Fig. 12. Secure with screws supplied in envelope in carton.

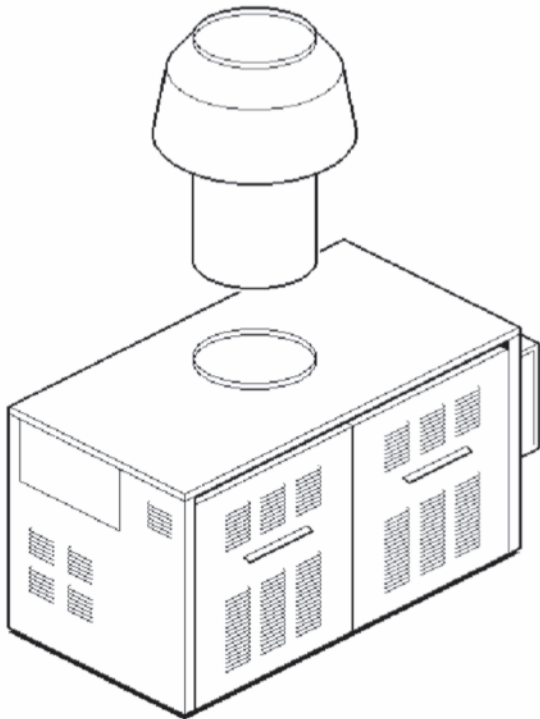

Fig. 12: Drafthood Installation—Models 0962-1826

Models 2100-4001

These models have built-in drafthoods. For proper operation, the drafthood outlet must be connected to the venting system.

Vent Piping

WARNING: Indoor boilers require a drafthood that must be connected to a vent pipe and properly vented to the outside. Failure to follow this procedure can cause fire or fatal carbon monoxide poisoning.

Vent piping the same size or larger than the drafthood outlet is recommended, however, when the total vent height is at least 10 ft. (drafthood relief opening to vent terminal), the vent pipe size may be reduced as specified in Chapter 10 of the latest edition of the National Fuel Gas Code (NFGC), ANSI Z223.1.

These units are certified for operation with cat I vents (natural draft conditions). Refer to the standard vent tables in the NFGC.

As much as possible, avoid long horizontal runs of vent pipe and too many elbows. If installation requires horizontal non-vertical runs, the vent pipe must have a minimum of 1/4 inch per foot rise and should be supported at not more than 5 ft. intervals. Plumbers tape, criss-crossed, will serve to space both horizontal and vertical piping.

Gas vents supported only by the flashing and extending above the roof more than 5 ft. should be securely guyed or braced to withstand snow and wind loads.

Raypak recommends the use of insulated vent pipe spacers through the roof and walls.

For protection against rain or blockage by snow, the vent pipe must terminate with a vent cap which complies with the local codes or, in the absence of such codes, to the latest edition of the National Fuel Gas Code, ANSI Z223.1.

The discharge opening must be a minimum of 2 ft. vertically from the roof surface and at least 2 ft. higher than any part of the building within 8 ft. for vents smaller than 12 in. diameter. For 12 in. diameter vents and larger, the termination must be 2 ft. higher than any part of the building within 10 ft. (See Fig. 14)*

Vent stack shall be at least 5 ft. in vertical height above the drafthood outlet. The vent cap location shall have a minimum clearance of 4 feet horizontally from, and in no case above or below, unless a 4-foot horizontal distance is maintained, from electric meters, gas meters regulators and relief equipment.

The weight of the vent stack or chimney must not rest on boiler drafthood. Support must be provided in compliance with applicable codes. The boiler top and drafthood must be readily removable for maintenance and inspection. Vent pipe should be adequately supported to maintain proper clearances from combustible construction.

Type "B" double-wall or equivalent vent pipe is recommended. However, single-wall metal vent pipe may be used as specified in the latest edition of the NFGC.

Manifolds that connect more than one boiler to a com-

mon chimney must be sized to handle the combined load. Consult available guides for proper sizing of the manifold and the chimney. At no time should the area be less than the area of the largest outlet. At the time of removal of an existing boiler, the follow-

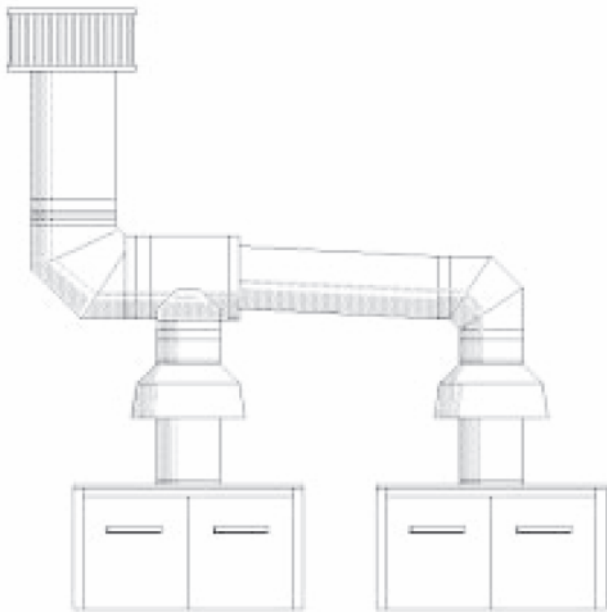

Fig. 13: Common Venting

ing steps shall be followed with each appliance remaining connected to the common venting system placed in operation, while the other appliances remaining connected to the common venting system are not in operation.

- (a) Seal any unused openings in the common venting system.
- (b) Visually inspect the venting system for proper size and horizontal pitch and make sure there is no blockage or restriction, leakage, corrosion and other deficiencies which could cause an unsafe condition.
- (c) As much as possible, close all building doors and windows and all doors between the space in which the appliances remaining connected to the common venting system are located and other spaces of the building. Turn on clothes dryers and any appliance not connected to the common venting system. Turn on any exhaust fans, such as range hoods and bathroom exhausts, so they will operate at maximum speed. Do not operate a summer exhaust fan. Close fireplace dampers.

LESS THAN 12" DIA VENT - WITHIN 8'
 12" OR LARGER DIA VENT - WITHIN 10'
 *(SEE VENT PIPING INSTRUCTIONS)

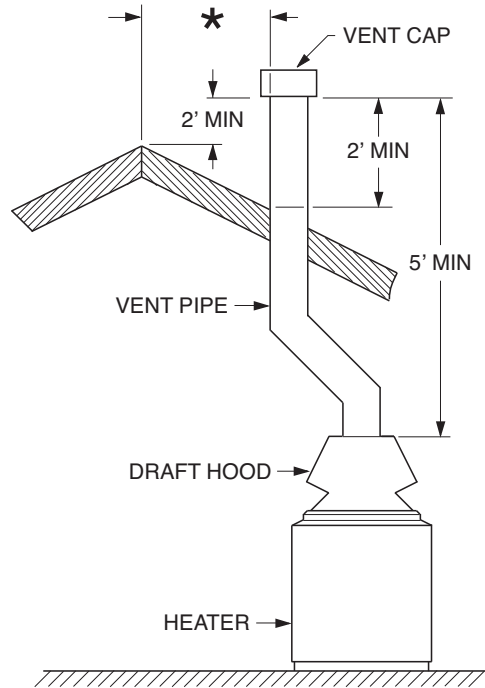

Fig. 14: Venting Clearances

- (d) Place in operation the appliance being inspected. Follow the lighting instructions. Adjust thermostat so appliance will operate continuously.
- (e) Test for spillage at the draft hood relief opening after 5 minutes of main burner operation. Use the flame of a match or candle, or smoke from a cigarette, cigar or pipe.
- (f) After it has been determined that each appliance remaining connected to the common venting system properly vents when tested as outlined above, return doors, windows, exhaust fans, fireplace dampers and any other gas burning appliance to their previous conditions of use.
- (g) Any improper operation of the common venting system should be corrected so that the installation conforms with the latest edition of the NFGC. When re-sizing any portion of the common venting system, the common venting system should be re-sized to approach the minimum size as determined using the appropriate tables in Chapter 13 of the NFGC.

For special venting applications that require reduced vent sizes, or through-the-wall venting, the Type D Induced Draft Assembly can be used. Consult the factory or your local Raypak representative.

Vent Damper Installation

(Models 0181 Through 0261) Where Required

Location

The vent damper must be located in the vent so that it serves only the appliance for which it is intended.

If improperly installed, a hazardous condition, such as an explosion or carbon monoxide poisoning, could result. Make certain that it is mounted in an accessible location at least 6 inches from any combustible material or the heat exchanger, and that the position indicator is in a visible location.

The vent damper must be installed after the appliance drafthood, as close to the drafthood as practicable, and without modification of the drafthood.

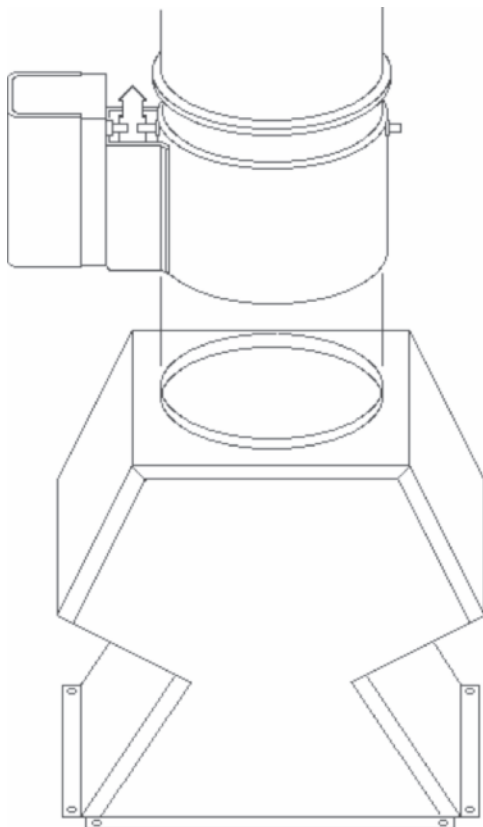

Fig. 15: Vent Damper Installation on Drafthood

WARNING: Do not use thermally actuated vent dampers on a modulating boiler. To do so may result in asphyxiation. Use only a mechanically actuated vent damper device that is electrically interlocked with the modulating boiler operation.

On vertical vents, the vent damper may be mounted with the actuator in any position. On horizontal vents, do not mount the actuator either directly above or directly below the vent pipe; mount the vent damper actuator to the side of the vent.

The vent damper ships set up for a continuous pilot system. Since the Raytherm is equipped with an Intermittent Pilot, the hole in the vent damper blade must be plugged using the knockout plug, Part No. 105612R, provided in the parts envelope.

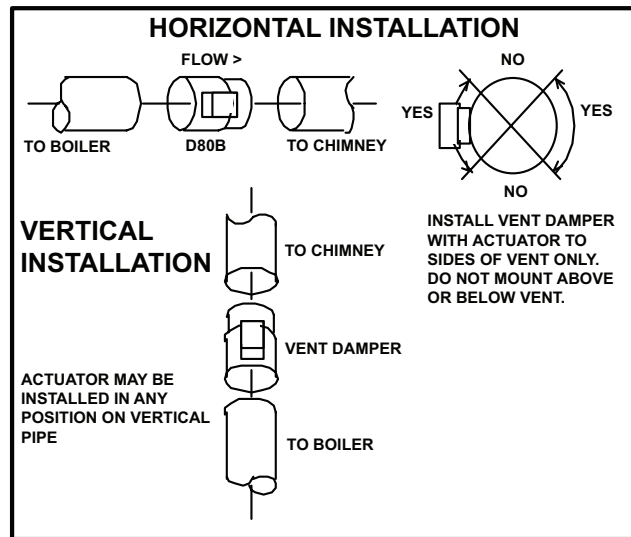

Fig. 16: Horizontal/Vertical Vent Damper Installation

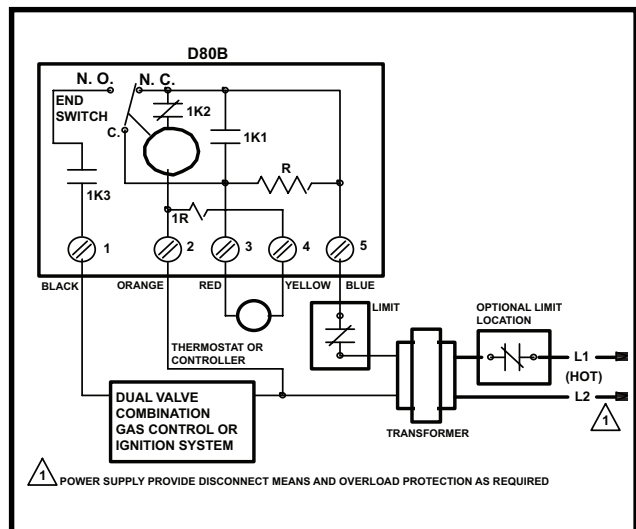

Fig. 17: Vent Damper General Wiring Diagram

CAUTION: Install the vent damper to service only the single appliance for which it is intended. If improperly installed, a hazardous condition, such as an explosion or carbon monoxide poisoning, could result.

Vent Damper

Normal Operation Summary

For safe, efficient operation, the vent damper and all flue product carrying areas of the appliance must be checked annually, with particular attention given to deterioration from corrosion or other sources. Check vent damper operation as follows:

1. When the boiler is off, check that the vent damper position indicator points to the closed position. (See figure below.)
2. Turn the thermostat or controller up to call for heat and check that the vent damper indicator points to the open position. (See figure below.)
3. Turn the thermostat or controller down again and check that the vent damper position indicator returns to the closed position.

NOTE: The vent damper must be inspected at least once a year by a trained, experienced service technician. Damper must be in open position when boiler main burners are operating.

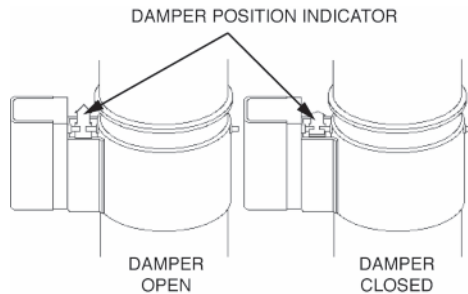

Fig. 18: Vent Damper Position Indicator

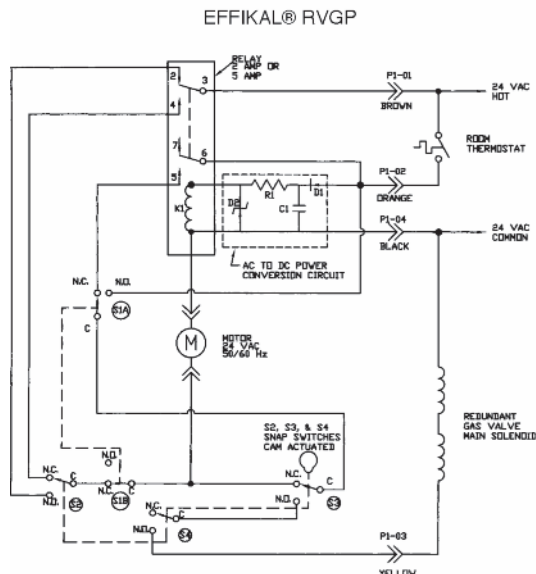

Fig. 19: Connection Diagram for Effikal® Vent Damper

Plumbing

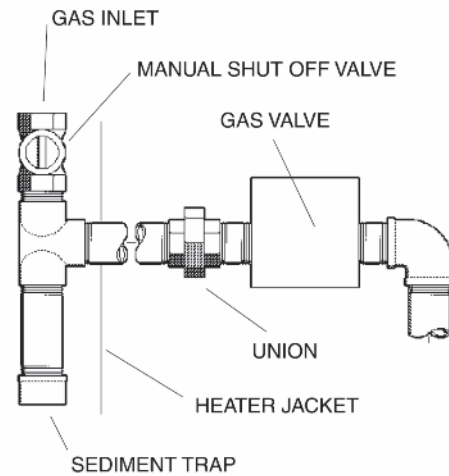

Fig. 20: Plumbing

Gas Supply Connections

Gas piping must have a sediment trap ahead of the boiler gas controls, and a manual shut-off valve located outside the heater jacket. All gas piping should be tested after installation in accordance with local codes.

NOTE: Do not use teflon tape on gas line pipe thread. A flexible sealant approved for the fuel being used is recommended.

CAUTION: The boiler and its manual shut-off valve must be disconnected from the gas supply during any pressure testing of that system at test pressures in excess of 1/2 PSIG. Dissipate test pressure in the gas supply line before reconnecting the boiler and its manual shut-off valve to gas supply line. FAILURE TO FOLLOW THIS PROCEDURE MAY DAMAGE THE GAS VALVE. OVER-PRESSURED GAS VALVES ARE NOT COVERED BY WARRANTY. The boiler and its gas connections shall be leak tested before placing the appliance in operation. Use soapy water for leak test do NOT use open flame.

A minimum of 7.0" W.C. upstream gas pressure under full load and a maximum gas supply pressure setpoint of 10.5" W.C. under load and no-load conditions for natural gas. A minimum of 12.0" W.C. upstream gas pressure under full load and a maximum gas supply pressure of 13.0" W.C. is required for propane gas. If upstream pressure exceeds 1/2 psi at any time, an intermediate gas pressure regulator, of the lockup type, must be installed.

MAXIMUM EQUIVALENT PIPE LENGTH																		
NATURAL GAS 1000 BTU/FT									.60 SPECIFIC GRAVITY @ 05" WC. PRESSURE DROP									
PROPANE GAS 2500 BTU/FT									1.53 SPECIFIC GRAVITY @ 0.6" WC. PRESSURE DROP									
1/2"		3/4"		1"		1-1/4"		1-1/2"		2"		2-1/2"		3"		4"		
N	P	N	P	N	P	N	P	N	P	N	P	N	P	N	P	N	P	
*0182/0181	-	15	30	65	95	250	400	-	-	-	-	-	-	-	-	-	-	-
*0260/0261	-	10	20	40	60	140	250	560	-	-	-	-	-	-	-	-	-	-
*0330/0331	-	-	15	25	35	85	150	380	360	-	-	-	-	-	-	-	-	-
*0400/0401	-	-	-	15	25	60	100	260	250	-	-	-	-	-	-	-	-	-
0514	-	-	-	10	15	35	65	150	130	360	500	-	-	-	-	-	-	-
0624	-	-	-	-	10	25	45	100	95	250	340	-	-	-	-	-	-	-
0724	-	-	-	-	-	20	35	80	75	180	260	600	-	-	-	-	-	-
0824	-	-	-	-	-	15	25	60	55	130	185	480	500	-	-	-	-	-
0926/0962	-	-	-	-	-	15	20	45	45	110	150	360	400	-	-	-	-	-
1083/1125	-	-	-	-	-	10	15	35	35	80	120	300	300	-	-	-	-	-
1178/1223	-	-	-	-	-	-	-	25	25	60	85	220	200	-	-	-	-	-
1287/1336	-	-	-	-	-	-	-	25	20	55	75	180	170	325	560	-	-	-
1414/1468	-	-	-	-	-	-	-	20	15	45	65	150	165	300	500	-	-	-
1571/1631	-	-	-	-	-	-	-	15	15	35	50	120	125	250	400	-	-	-
1758/1826	-	-	-	-	-	-	-	15	10	30	40	100	100	225	340	-	-	-
2100	-	-	-	-	-	-	-	10	10	25	30	80	75	175	260	-	-	-
2500	-	-	-	-	-	-	-	-	-	15	20	55	55	135	160	400	600	-
3001	-	-	-	-	-	-	-	-	-	10	15	35	40	85	120	250	500	-
3500	-	-	-	-	-	-	-	-	-	-	10	30	30	45	80	200	400	600
4001	-	-	-	-	-	-	-	-	-	-	5	20	25	35	65	160	300	400

BOLD TYPE Indicates Low NOx models.

*Low NOx units not available for propane.

Table G: Maximum Equivalent Pipe Length

Gas Pressure Regulator

The manifold gas pressure regulator is preset nominally at 4" W.C. for natural gas, and 11" W.C. for propane. Between the gas valve and the burners is a 1/8" pipe plug. The pressure at this point, taken with a manometer, should be about 3.7" W.C. for natural gas and 10.5" W.C. for propane. Low NOx models should be 3.9" W.C., natural gas only. If an adjustment is needed, turn adjustment screw clockwise to increase pressure, or counter-clockwise to decrease pressure.

For boilers with mechanical modulation gas valves (Type H1 and H5) or two-stage gas valves (Type H3), the gas pressure regulator is preset and sealed, and not field adjustable. Pressure tap is provided on the outlet side of the gas valve for measurement of gas pressure in the manifold.

Venting of Diaphragm Gas Components

Gas valves that are equipped with a gas bleed must be vented to the outdoors as required by the National Fuel Gas Code. Under NO circumstances shall bleed lines terminate in the gas utilization equipment flue or exhaust system.

General

Boiler should be located so that any water leaks will not cause damage to any adjacent areas or structures. See piping diagrams for proper water connections for the type of boiler and system.

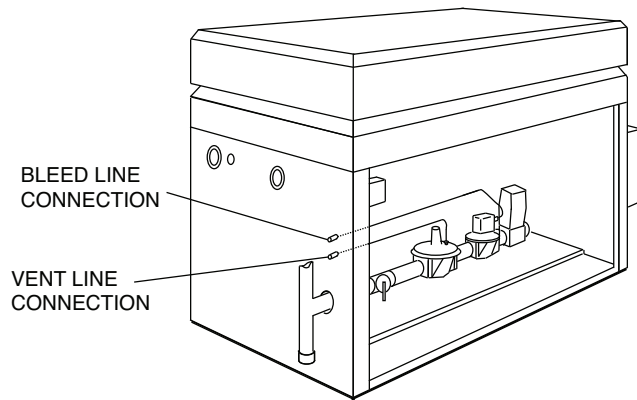

Fig. 21: Bleed Line Connection Location

Pump Selection

In order to ensure proper hydraulics in your hydronic heating system, adequate pump size must be selected. Raypak recommends that the pump be sized for 20°F Delta-T whenever possible. (Delta-T is the temperature difference between the inlet and outlet water when the boiler is firing at full rate). For some boilers, the Delta-T is more than 20°F (22°-33°F) at the recommended flow rates.

Feedwater Regulator

Raypak recommends that a feedwater regulator be installed and set at 12 PSIG minimum pressure. Install a check valve or back flow device upstream of the regulator, with a manual shut-off valve. Leave the valve open.

MAXIMUM AND MINIMUM FLOW RATES														
MODEL SIZE	2-PASS HEAT EXCHANGER						HDR CONN	1-PASS HEAT EXCHANGER						
	MAX			MIN				MAX			MIN			HDR CONN
	GPM	ΔT	ΔP FT.	GPM	ΔT	ΔP FT.	GPM	ΔT	ΔP FT.	GPM	ΔT	ΔP FT.		
0182/0181	45	7	9.2	20	15	1.8	1-1/2"							
0260/0261	45	10	9.4	20	22	1.9	1-1/2"							
0330/0331	45	12	9.6	20	28	1.9	1-1/2"							
0400/0401	45	15	9.8	20	33	2.0	1-1/2"							
0514	90	9	9.0	40	21	1.8	2"							
0624	90	12	9.5	40	26	1.9	2"							
0724	90	13	10.0	40	30	2.0	2"							
0824	90	15	10.5	40	34	2.1	2"							
0926	90	17	11.0	40	38	2.2	2-1/2"	200	8	9.7	90	17	2.1	3"
0962	90	18	11.0	40	40	2.2	2-1/2"	200	8	9.7	90	18	2.1	3"
1083	90	20	12.0	45	40	3.1	2-1/2"	200	9	10.3	90	20	2.3	3"
1125	90	21	12.0	47	40	3.3	2-1/2"	200	9	10.3	90	20	2.3	3"
1178	90	22	12.5	49	40	3.8	2-1/2"	200	10	11	90	21	2.4	3"
1223	90	22	12.5	51	40	4.0	2-1/2"	200	10	11	90	22	2.4	3"
1287	90	24	13.2	53	40	4.5	2-1/2"	200	11	11.7	90	23	2.5	3"
1336	90	24	13.2	55	40	4.9	2-1/2"	200	11	11.7	90	24	2.5	3"
1414	90	26	14.0	58	40	5.8	2-1/2"	200	12	12.2	90	26	2.7	3"
1468	90	27	14.0	61	40	6.4	2-1/2"	200	12	12.2	90	27	2.7	3"
1571	90	29	14.5	65	40	7.5	2-1/2"	200	13	13	90	29	2.8	3"
1631	90	30	14.5	68	40	8.3	2-1/2"	200	13	13	90	30	2.8	3"
1758	90	32	15.4	73	40	10.0	2-1/2"	200	14	14.7	90	32	3.0	3"
1826	90	34	15.4	76	40	10.8	2-1/2"	200	15	14.7	90	33	3.0	3"
2100	200	17	14.8	90	39	3.2	3"	400	9	18	180	19	4.0	4"
2500	200	21	15.8	103	40	4.4	3"	400	10	18.8	180	23	4.1	4"
3001	200	25	16.7	124	40	6.7	3"	400	12	19.5	180	27	4.3	4"
3500	200	29	17.5	145	40	9.5	3"	400	14	20.5	180	32	4.5	4"
4001	200	33	18.7	166	40	13.0	3"	400	16	21.5	180	36	4.7	4"

GPM Flow rates limited by maximum acceptable velocity through heat exchanger tubes. May be increased by 10% for closed heating systems.

BOLD TYPE indicates Low NOx models.

Table H: Maximum and Minimum Flow Rates

Piping—Heating Boilers

Raypak recommends that all high points be vented and that purge valves and a bypass valve be installed. A boiler installed above radiation level must be provided with a low-water cut-off device. The boiler, when used in conjunction with a refrigeration system, must be installed so that the chilled medium is piped in parallel with the boiler with appropriate valves to prevent the chilled medium from entering the boiler.

Raypak strongly recommends the use of primary/secondary piping for all H boilers, as shown in the following piping diagrams. System flow must exceed the flow through the boiler at all firing rates.

Hot water heating systems all have unique levels of operating diversity that must be accounted for in the system design. The system should always include adequate system flow in excess of the connected boiler flow for proper operation. Where the system flow may drop below the connected boiler flow a buffer/decoupler may be needed. Failure to design for adequate flow (i.e. bypasses, 3 way control valves, flow limiting balance devices, buffer tanks, etc.) will result in boiler short-cycling and may reduce boiler life. Always contact your local Raypak representative for system design assistance to avoid these issues.

Min 105F water temp at the inlet to avoid condensation.

Recommended Purge Manifolds for Typical Hydronic System Hookups

The boiler piping system of a hot water heating boiler connected to heating coils located in air handling units where they may be exposed to refrigerated air circulating, must be equipped with flow control valves or other automatic means to prevent gravity circulation of the boiler water during the cooling cycle.

Temperature & Pressure Gauge

The temperature & pressure gauge is standard equipment on all hydronic heating and hot water supply boilers. All temperature & pressure gauges are factory mounted in the in/out header except for residential boilers, Models 0181-0401. On these models the temperature & pressure gauge is shipped loose for field installation, and located in the outlet water connection. All fittings required to mount gauge to piping system are supplied by others.

THIS PIPING DIAGRAM IS RAYPAK'S RECOMMENDATION AND IS NOT INTENDED TO REPLACE AN ENGINEERED PIPING SYSTEM DESIGNED BY A PROFESSIONAL ENGINEER.

PIPE SIZES	
RAYTHERM BOILER	1-1/2"
181-401	2"
514-824	2-1/2"
926-1826	3"
2100-4001	

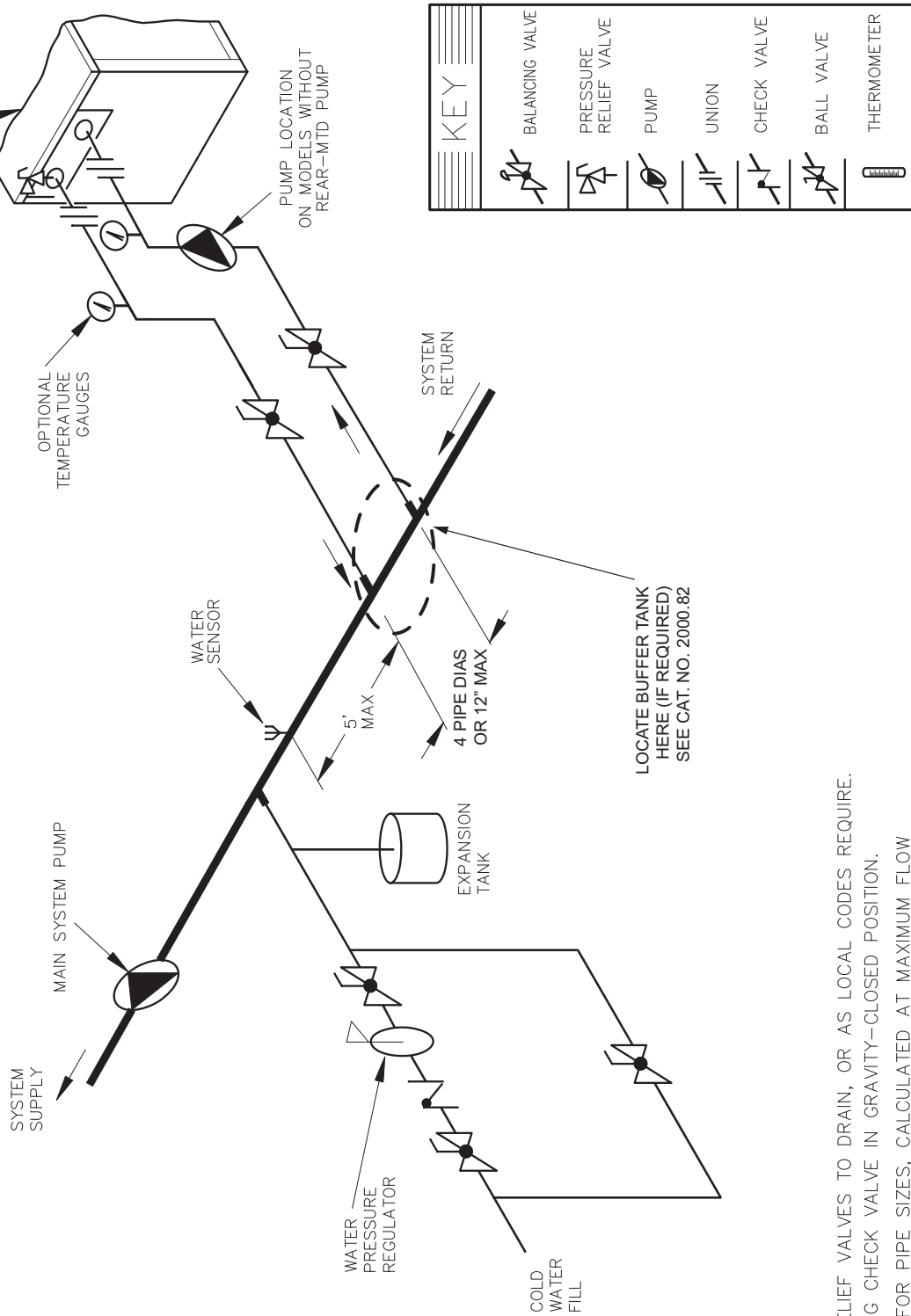

- NOTES:
1. PIPE ALL RELIEF VALVES TO DRAIN, OR AS LOCAL CODES REQUIRE.
 2. PLUMB SWING CHECK VALVE IN GRAVITY-CLOSED POSITION.
 3. SEE TABLE FOR PIPE SIZES, CALCULATED AT MAXIMUM FLOW IF LOWER FLOW RATES THAT ARE ACCEPTABLE FOR THE UNIT ARE USED, SMALLER PIPE SIZES MAY BE USED.

Note: Expansion tanks (supplied by others) should be installed per manufacturer's instructions.

Fig. 22: Single Boiler Primary/Secondary Piping—Models 181-4001

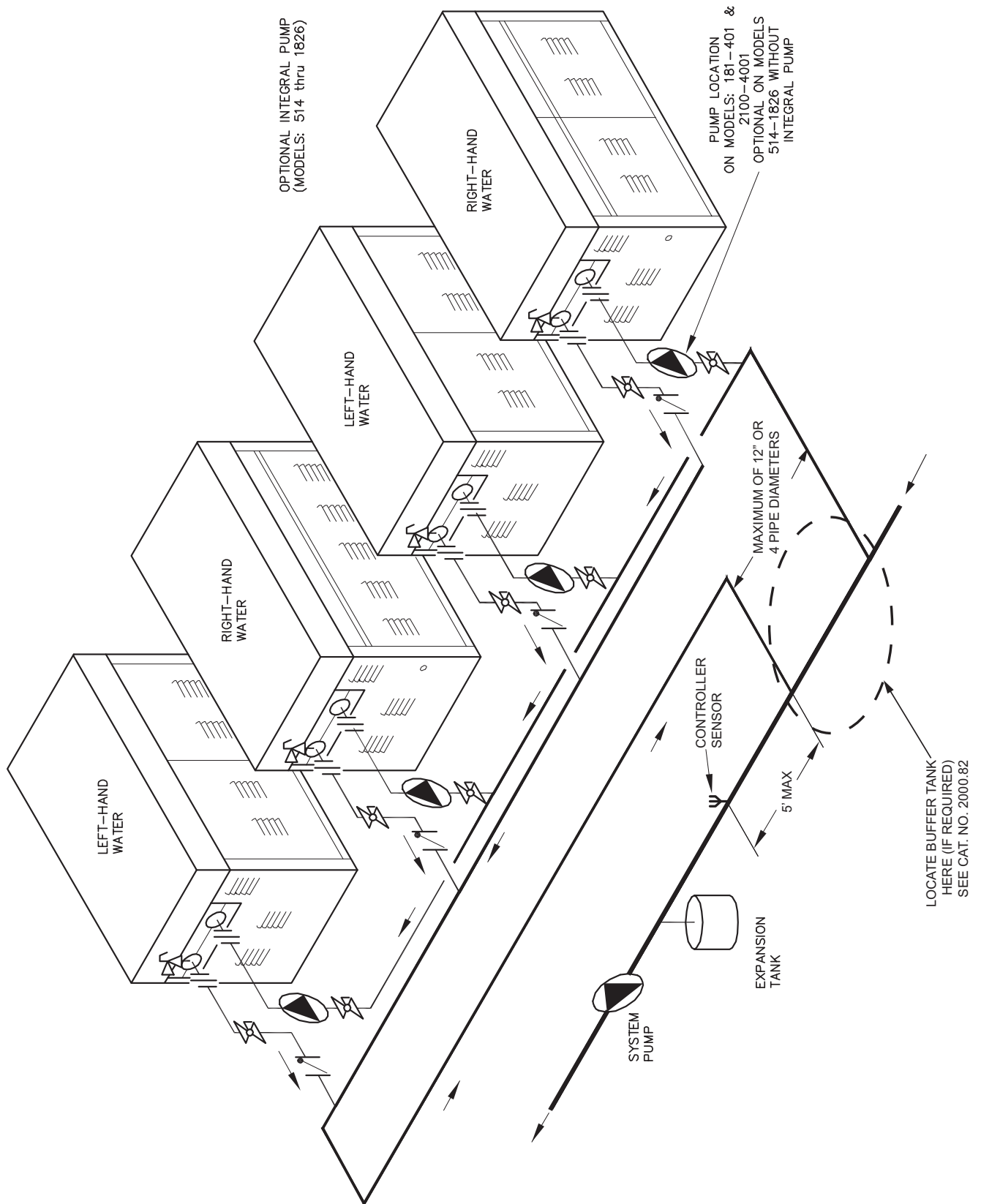

Reverse return piping is a proper method of manifolding multiple boiler hook-ups to ensure balanced flow through each boiler. Valves on supply and return are needed to isolate any boiler, as required.

Fig. 23: Multiple-Boiler- Reverse Return Hook-Up—Models 181-4001

CONTROLS

Economaster Controls

The Economaster II is an electronic device that allows the operator to set the desired time for the pump to run after the boiler shuts off. The time is factory-set at 7 minutes and it can be re-adjusted in the field anywhere from 3 to 10 minutes.

In a conventional system, when the aquastat is satisfied, the main gas valve closes, but the pump continues operating. With the energy-conserving Economaster II the boiler pump is programmed to continue running for an optimum period of time in order to absorb the residual heat from the combustion chamber and use it in the system. The pump then shuts off until the next call for heat is received from the aquastat.

NOTE: Pump will come on when power is first applied to boiler.

NOTE: Boiler pump delay is built into the Outdoor Air Reset Temperature Controller, and is fixed at 5 minutes.

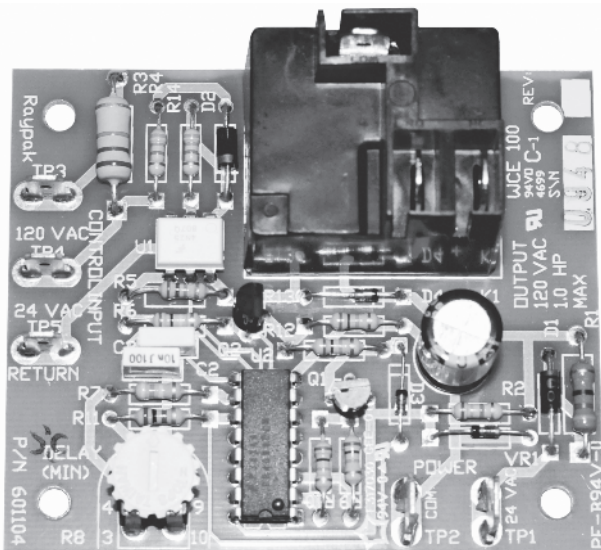

Fig. 24: Economaster PCB

Electronic Ignition

The intermittent ignition device conserves energy by automatically extinguishing the pilot when desired temperature is reached. When additional heat is needed, the pilot re-ignites electrically, eliminating the fuel costs of maintaining a constant pilot. To ensure safe operation, the gas valve cannot open until the pilot relights and is proven.

Models 0181-0401, when built to operate on natural gas, are equipped with a continuous retry pilot ignition module as standard. Propane units, as well as all 0514-4001 units regardless of fuel type, are equipped with a 90 second trial for pilot ignition - lockout ignition module as standard.

Outdoor Air Reset Temperature Controller

Models 0181 through 0261 are factory-equipped with an electronic outdoor air reset temperature controller. This controller is also an available option for models 0330 through 0401.

The standard configuration provides for outdoor air reset of the system target water temperature based on a user-defined reset ratio. The controller will reset between 120°F system water temperature and allow for a maximum boiler outlet of 210°F. The controller will provide two stage firing of the heater. The controller is also equipped with a connection for an external thermostat input for use with an indirect load such as an indirect DHW tank for hot water production. When used for direct DHW in conjunction with a storage tank, the controller can be configured to provide fixed setpoint operation.

The primary functions of the controller are set using the Operating Temperature dial and the DIP switches. See Table I. The controller has 4 LEDs to indicate the its condition:

Power - *On Solid* - Turns on when 24 Vac Power is present.

Heat Call - *On Solid* - Turns on when Heat Call (short or 0-32 Vac) is present.

Flashing - Boiler outlet sensor error. While present, operation ceases.

IND Call - *On Solid* - Turns on when IND Call (short or 0-32 Vac) is present.

Flashing - System supply sensor error. While present, operation continues using boiler outlet sensor.

WWSD - *On Solid* - Turns on when in Outdoor Reset AND WWSD Active AND control in WWSD.

Flashing - Outdoor sensor error. While present, operation continues with Fixed boiler target temp of 140°F based on 32°F air.

ITEM	FEATURE	SETTING / DESCRIPTION	DEFAULT
Dial	Operating Temperature	Reset Ratio 0.4 to 3.6 / Setpoint Target 120°F to 200°F	Reset Ratio 0.4 to 3.6
DIP #1	Firing Mode	Single Stage (On) / Two Stage (Off)	Single Stage (On)
DIP #2	Configuration	Outdoor Reset (On) / Setpoint (Off)	Outdoor Reset (On)
DIP #3	Warm Weather Shut Down	Active 70°F (On) / Inactive (Off)	Active 70°F (On)
DIP #4	Boiler Max Outlet Setting	Boiler Maximum (dependent on DIP #5) - Default: On o If DIP #5 set to Hydronic (On): 210°F (Off) / 190°F(On) o If DIP #5 set to Direct DHW (Off): 180°F (Off) / 160°F(On)	190°F(On)
DIP #5	Space Heating or Direct Domestic Hot Water	Direct DHW (Off) / Hydronic (On) - Default: Hydronic (On) <i>Note: If DIP #5 is set to Direct DHW (Off), the operation is based on Setpoint regardless of DIP #2 setting.</i>	Hydronic (On)

Table I: Outdoor Air Reset Temperature Controller Settings

Hydronic with Outdoor Air Reset

For hydronic operation with outdoor air reset, the System Supply Sensor (S2) is used as the operating sensor. Boiler Outlet Sensor (S1) is used for boiler outlet maximum limiting. Boiler Pump (P1) is controlled by the boiler and is cycled off using a 5 minute fixed purge delay after burner operation has ceased.

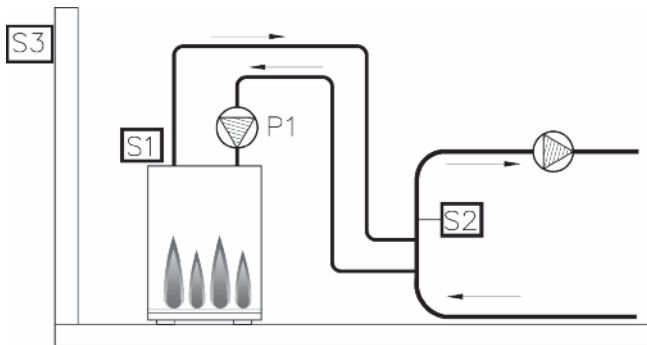

S1 = Boiler Outlet Sensor
S2 = System Supply Sensor
S3 = Outdoor Air Sensor
P1 = Boiler Pump

Fig. 25: Hydronic with Outdoor Air Reset

The DIP switch settings are as follows:

- DIP 1 ON (ON/OFF) – OFF (2-STAGE)
- DIP 2 ON (OUTDOOR RESET)
- DIP 3 ON (WWSD 70°F)
- DIP 4 ON (190°F BOIL MAX)
- DIP 5 ON (HYDRONIC)

Hydronic, Outdoor Air Reset with Indirect DHW

For hydronic operation with outdoor air reset and Indirect DHW, the System Supply Sensor (S2) is used as the operating sensor. Boiler Outlet Sensor (S1) is used for boiler outlet maximum limiting. Contact closure from an aquastat located on an indirect DHW tank will cause the controller to operate to a boost temperature to satisfy the indirect call for heat. Once the aquastat opens the controller will return to normal operation. The indirect pump is operated by an external relay (by others). The Boiler Pump (P1) is controlled by the boiler and is cycled off using a 5 minute fixed purge delay after burner operation has ceased.

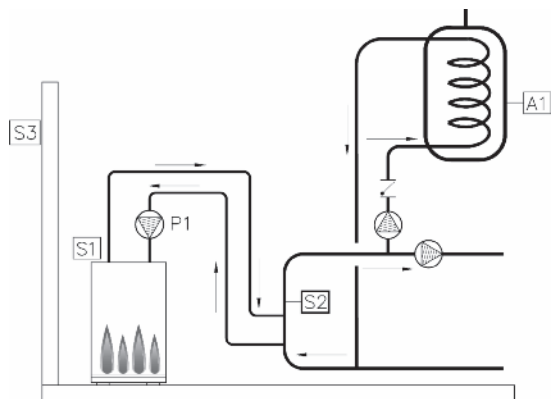

Fig. 26: Hydronic with Outdoor Air Reset and Indirect DHW

The DIP switch settings are as follows:

- DIP 1 ON (ON/OFF) – OFF (2-STAGE)
- DIP 2 ON (OUTDOOR RESET)
- DIP 3 ON (WWSD 70°F)
- DIP 4 ON (190°F BOIL MAX)
- DIP 5 ON (HYDRONIC)

Ratio	Water Temperature									
	3.6:1	120	156	192						
3.2:1	120	152	184	216						
2.8:1	120	148	176	204						
2.4:1	120	144	168	192	216					
2.0:1	120	140	160	180	200	220				
1.6:1	120	136	152	168	184	200	216			
1.2:1	120	132	144	156	168	180	192	204	216	
.8:1	120	128	136	144	152	160	168	176	184	192
.4:1	120	124	128	132	136	140	144	148	152	156
	70	60	50	40	30	20	10	0	-10	-20
	Outdoor Air Temperature - °F									

Table J: Reset Ratio

Direct Domestic Hot Water

In this configuration the controller will operate to maintain a set temperature in the storage tank. The differential is fixed at 5F below target. The System Supply Sensor (S2) is used as the operating sensor. Boiler Outlet Sensor (S1) is used for boiler outlet maximum limiting. Boiler Pump (P1) is controlled by the boiler and is cycled off using a 5 minute fixed purge delay after burner operation has ceased.

The DIP switch settings are as follows:

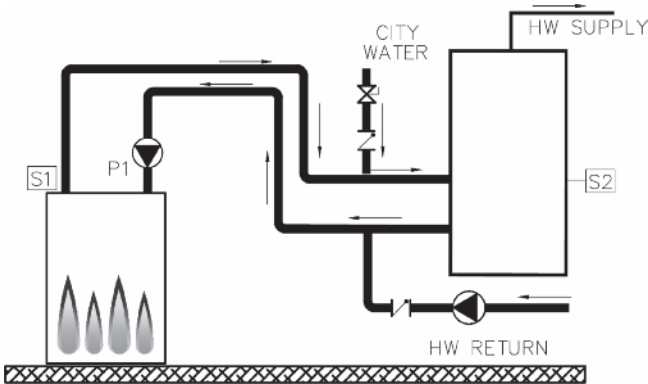

Fig. 27: Direct Domestic Hot Water

- DIP 1 ON (ON/OFF) – OFF (2-STAGE)
- DIP 2 OFF (SETPOINT)
- DIP 3 OFF (WWSD INACTIVE)
- DIP 4 ON (160°F BOIL MAX)
- DIP 5 OFF (DIRECT DHW)

Operating Controls

Modes H1 and H5 - Mechanical Modulation

Available on sizes 0330-1826

Models with mechanical modulating controls have one or more Robertshaw (Invensys) Unitrol 7000 Series hydraulic snap-on thermostatic combination gas

valves. These dual-seat combination valves have the pressure regulator and 24 volt operator built-in. The hydraulic actuator will throttle the boiler input to adjust the firing rate and meet the required load. This, in effect, prevents costly fuel consumption, as compared to an on-off cycling boiler.

The valve has a remote capillary bulb immersed in a well, at the header outlet, to maintain a constant outlet water temperature. When multiple valves are furnished, they can be staged to give greater flexibility of control. Standard factory setting is at position 5. Consult the dial setting tag attached to the control for your desired temperature. See sample tag drawings below.

NOTE: No external control of the valve position is possible.

DIAL POSITION	TEMP. IN DEGREES F
POS. LO	110
POS. 1	117
POS. 2	124
POS. 3	130
POS. 4	137
POS. 5	143
POS. 6	150
POS. 7	156
POS. 8	163
POS. HI	170

P/N

Low Temp. Range
H5

DIAL POSITION	TEMP. IN DEGREES F
POS. LO	150
POS. 1	157
POS. 2	164
POS. 3	170
POS. 4	177
POS. 5	183
POS. 6	190
POS. 7	196
POS. 8	203
POS. HI	210

P/N

High Temp. Range
H1

Setting are Accurate

The temperature indicator is located on top of the modulator valve next to the valve "CHECK" knob. Set number for desired temperature next to setting indicator.

Fig. 28: Sample Tags

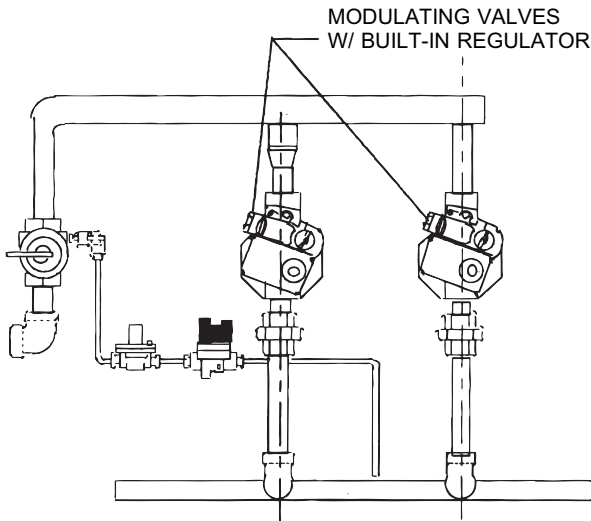

Fig. 29: Mechanical Modulating Valve Location
(sizes 0724-1336 shown)

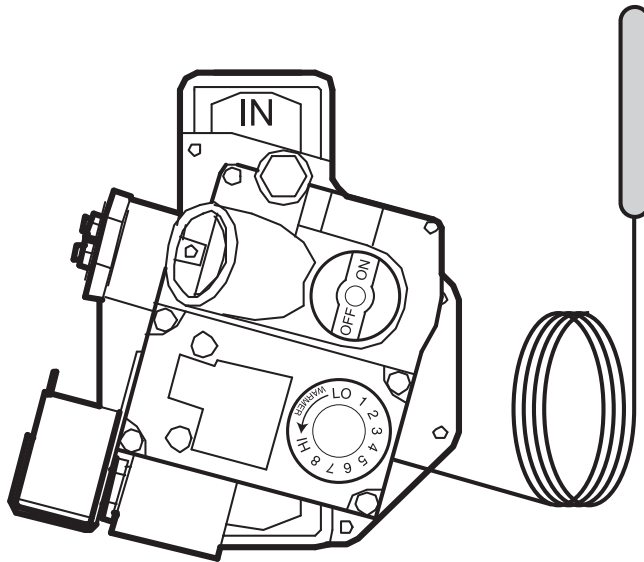

Fig. 30: Mechanical Modulating Valve

Mode H2 - Motorized Modulation

Available on sizes 0514-4001

This design uses a motorized valve which varies position based upon an external controller that communicates with the gas valve actuator, through a 3-wire 0-135 ohm wiper circuit. Minimum fire is 20% of rate. The actuator runs on 120V power, and takes 26 seconds to go from fully closed to fully open. Raypak offers a single-boiler digital controller which drives the actuator; see controller options B-40 and B-41 (includes outdoor reset). For systems with multiple boilers, see controller options B-36 through B-47. For a field-supplied controller with a 4-20 mA signal, see option B-35.

Mode H3 - 2-Stage Firing

Available on sizes 0181-4001

The boiler will fire at low fire when there is closure across the stage 1 contacts. Thereafter, it will fire at high fire when there is closure across the stage 2 contacts. Numerous staged controllers are available.

Mode H4 - On/Off Firing

Available on sizes 0181-4001

The boiler will fire at full fire when there is closure across the TH contacts. Numerous mechanical staged controllers are available (see Fig. 39), as well as digital controllers offering additional features. A typical wiring diagram for a mid-size H4 unit is shown on page 34; this basic layout applies to most other firing modes as well.

Mode H9 - 4-Stage Firing

Available on sizes 0514-4001

The boiler will fire at lowest setting when there is closure across the stage 1 contacts. Thereafter, it will fire at increasing rates when there is closure across the contacts for additional stages. Loss of closure across stage 1 will shut down the entire boiler immediately. Numerous digital controllers are available.

WH Modes

Controller connections for heating boilers used in domestic hot water service are shown in Figs. 31 and 32.

BREAK THE WIRE NUT AT THE BOILER "TH" CONNECTIONS AND ATTACH TO THE SINGLE TANKSTAT PER ILLUSTRATION

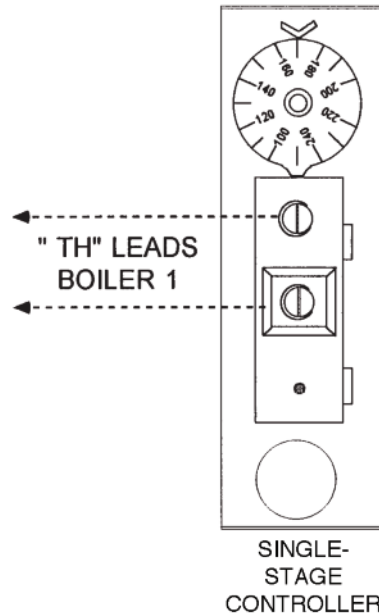

Fig. 31: Single Stage Controller

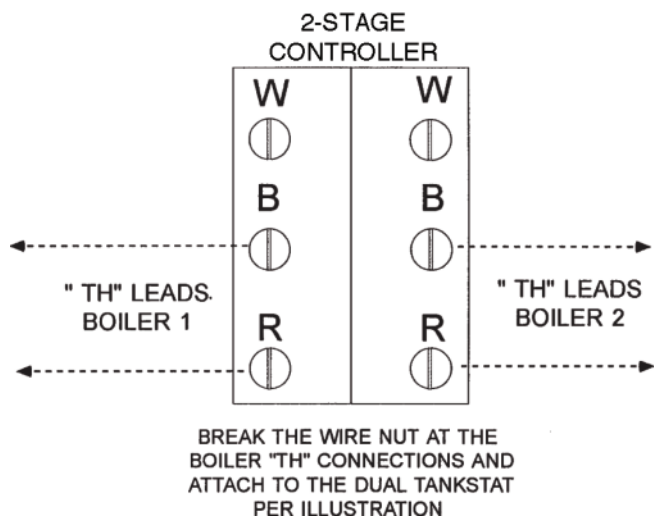

Fig. 32: 2-Stage Controller

Limit Controls

Manual-Reset High Limit

All models are equipped with a manual reset high limit. Set the manual limit to its maximum setpoint.

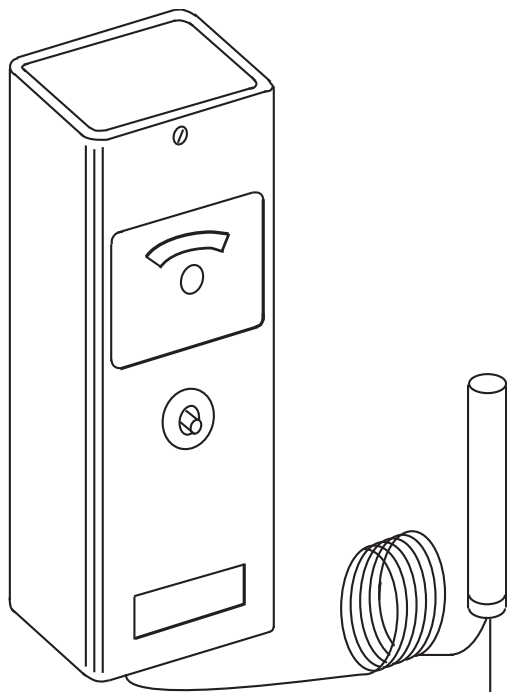

Fig. 33: Manual Reset High Limit

Auto-Reset High Limit

Set the auto limit(s) to 30-40 °F above the desired operating temperature and 15°F below the Manual High Limit setting.

Flow Switch

This dual purpose control shuts off the boiler in the case of a pump failure or low water condition. It is mounted and wired in series to the main gas valve. Standard on all models.

NOTE: Flow switch will not operate if flow is less than 12 gpm.

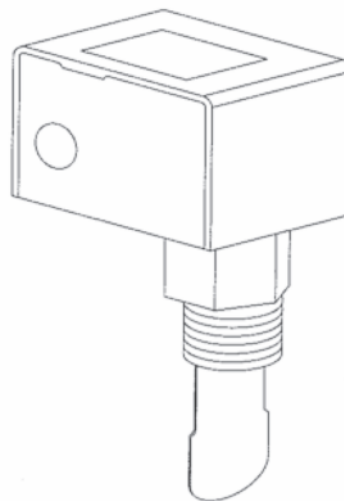

Fig. 34: Flow Switch

100% Pilot Safety

All standard boiler models 0181-4001 employ electronic devices which close the main gas valve within 8/10 of a second whenever the pilot flame is interrupted. Pilot flame is automatically lit when the device is powered. Unit performs its own safety check and opens the main valve only after the pilot is proven to be lit.

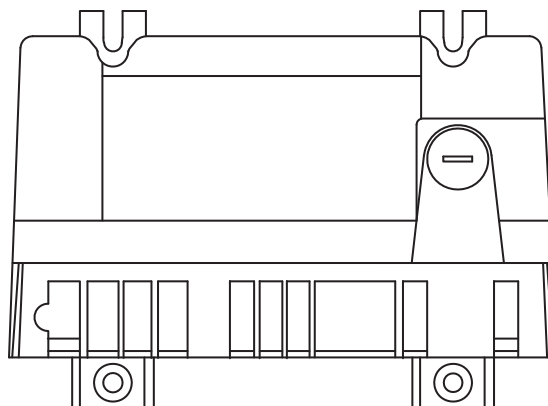

Fig. 35: Safety Control

Low Water Cut-Off (Optional)

On Models 0514-1826, the probe-type low-water cut-off automatically shuts down burner whenever water level drops below the probe for more than 2 seconds. A 3-second time delay prevents premature lockout due to temporary conditions such as power failure or air pockets.

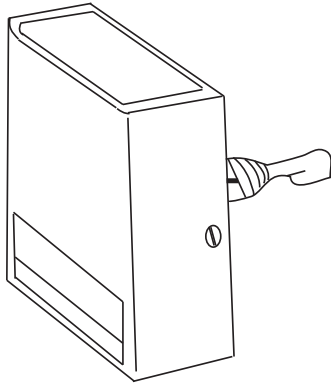

Fig. 36: Low-Water Cut-Off for Models 0514-1826

On Models 0181-0401, the low water cut-off automatically shuts down the burner whenever water level drops below the level of the sensing probe. A 5-second time delay prevents premature lockout due to temporary conditions such as power fluctuations or air pockets.

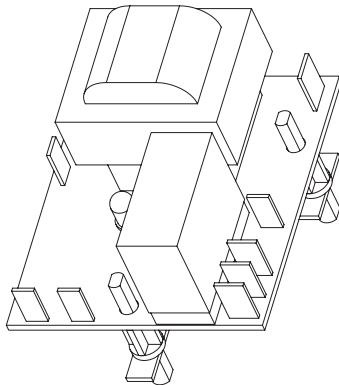

Fig. 37: Low-Water Cut-Off Board for Models 0181-0401

High-Gas and Low-Gas Pressure Switches (Optional)

NOTE: The High Gas Pressure Switch is standard on Models 3001-4001

These switches sense either high-gas or low-gas pressures and automatically shut down burners if abnormal pressures exist. The high gas pressure switch opens if the manifold pressure rises above 5.0 "WC. The low gas pressure switch opens if the inlet gas pressure drops below 5.0 "WC.

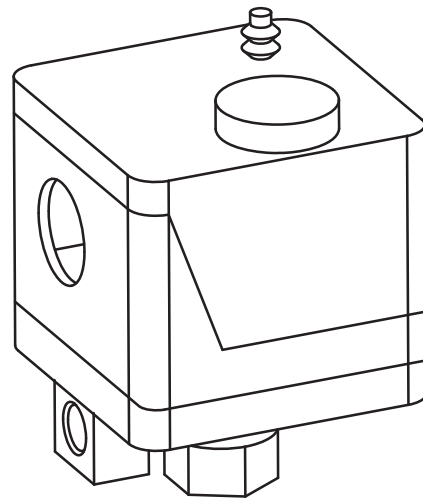

Fig. 38: Gas Pressure Switch

ELECTRICAL CONNECTIONS

CAUTION: Label all wires prior to disconnection when servicing controls. Wiring errors can cause improper and dangerous operation. Verify proper operation after servicing.

DANGER - SHOCK HAZARD: Make sure electrical power to the heater is disconnected to avoid potential serious injury or damage to components.

This boiler is normally wired for 120 Volts. The voltage is indicated on the tie-in leads. Consult the wiring diagram shipped with the boiler in the instruction packet. The "TH" leads are for the remote tank control connection. 24 Volts are supplied to this connection through the boiler transformer.

DO NOT attach line voltage to the "TH" leads on models 0181-1826. Before starting boiler check to ensure proper voltage to boiler and pump.

The boiler must be electrically grounded in accordance with National Electrical Code ANSI/NFPA No 70, or with CSA C22.1 C.E.C. Part 1 in Canada.

NOTES:

1. Field install ground to inside of junction box.
2. If any of the original wire as supplied with the boiler must be replaced, it must be replaced with 105°C wire or its equivalent.

GENERAL LOCATION OF CONTROLS

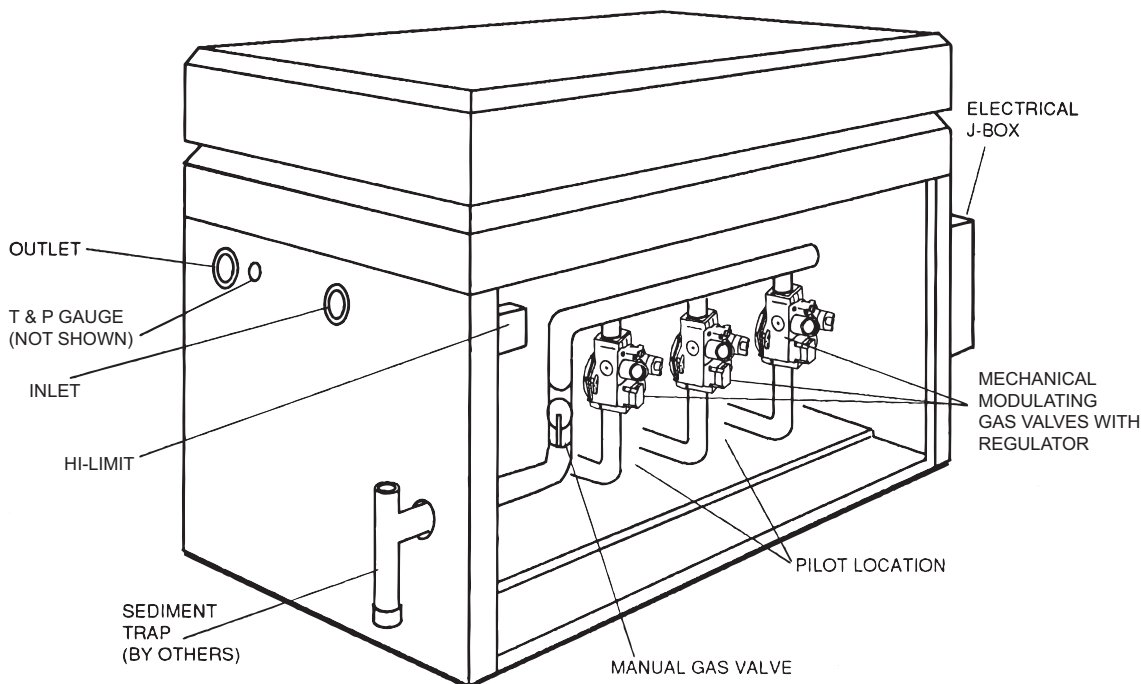

Fig. 39: General Location of Controls (H1/H5 1414-1826 shown)

START-UP

Before Start-Up

Safe lighting and other performance criteria were met with the gas manifold and control assembly provided on the boiler when the boiler underwent tests specified in the latest edition of ANSI Z21.13 Standard.

General

Before lighting up a new installation, water should be flowing through the boiler. Regulator should be set to minimum 12 PSI.

CAUTION: Propane gas is heavier than air and sinks to the ground. Exercise extreme care in lighting boiler in confined areas.

Filling System - Heating Boilers

Fill system with water. Purge all air from the system using purge valve sequence. After system is purged of air, lower system pressure. Open valves for normal system operation. Fill system through feed pressure. Manually open air vent on the compression tank until water appears, then close vent.

Ethylene Glycol Systems - Heating Boilers

Fill through filler opening on the top on the Air-X Tank to solution desired. Always maintain solution level in sight glass.

NOTE: Raypak recommends the use of Ethylene Glycol solution only.

Initial Start-Up - Pump and Motor

Many pumps are now direct-drive. They have no coupler or bearing assembly. These pumps do not require lubrication. Others require SAE-30 non-detergent oil to lubricate both the motor and the bearing assembly. Check pump motor for type before attempting to oil.

Clean dust and lint from pump and motor. Check pump coupler and tighten if necessary. Flush system before putting into operation to ensure that foreign material does not damage pump seals.

CAUTION: Pump must be off to check oil in bearing assembly. Do not run pump without water in system.

LIGHTING INSTRUCTIONS FOR BOILERS WITH ELECTRONIC IGNITION (IID)
For Models with Manual Gas Valves

FOR YOUR SAFETY READ BEFORE OPERATING

WARNING: If you do not follow these instructions exactly, a fire or explosion may result causing property damage, personal injury or loss of life.

- A. This appliance is equipped with an ignition device which automatically lights the pilot. Do not try to light the pilot by hand.
- B. BEFORE OPERATING smell all around the appliance area for gas. Be sure to smell next to the floor because some gas is heavier than air and will settle on the floor.
WHAT TO DO IF YOU SMELL GAS
 - * Do not try to light any appliance.
 - * Do not touch any electric switch; do not use any phone in your building.
 - * Immediately call your gas supplier from your neighbor's phone. Follow the gas supplier's instructions.
- * If you cannot reach your gas supplier, call the fire department.
- C. Use only your hand to push in or turn the gas control knob. Never use tools. If the knob will not push in or turn by hand, do not try to repair it, call a qualified service technician. Force or attempted repair may result in a fire or explosion.
- D. Do not use this appliance if any part has been under water. Immediately call a qualified service technician to inspect the appliance and to replace any part of the control system and any gas control which has been under water.

OPERATING INSTRUCTIONS

1. STOP! Read the safety information above.
2. Set the thermostat on the lowest setting.
3. Turn off all electrical power to the appliance.
4. This appliance is equipped with an ignition device which automatically lights the pilot. Do not try to light the pilot by hand.
5. Remove boiler door panel.
6. **For Robertshaw gas valve:** Turn gas control knob clockwise to "OFF".
For Honeywell gas valve (all models except 40#): Turn gas control knob clockwise to "OFF". Make sure knob rest against stop.
For Honeywell gas valve (Models 40# only): Push in gas control knob slightly and turn clockwise to "OFF". Knob cannot be turned to "OFF" unless knob is pushed in slightly. Do not force.
7. Wait five (5) minutes to clear out any gas. Then smell for gas, including near the floor. If you smell gas, STOP! Follow "B" in the safety information above. If you do not smell gas, go to the next step.
8. **For Robertshaw gas valve:** Turn gas control knob counter-clockwise to "ON".

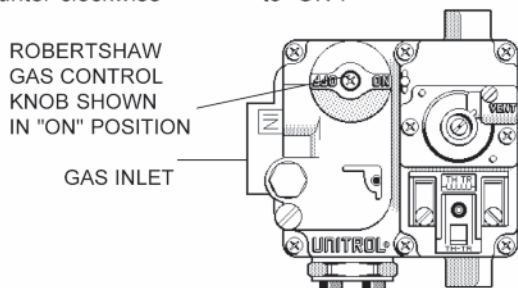

For Honeywell gas valve: Turn gas control knob counter-clockwise from "OFF" until it stops. Push in gas control knob and continue rotating counter-clockwise to "ON" position. Make sure knob rests against stop.

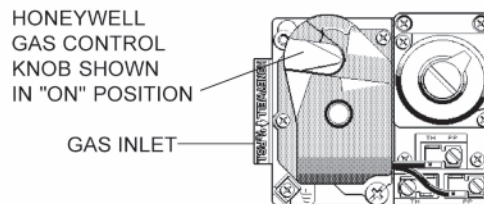

For Honeywell gas valve (Models 40# only): Turn gas control knob counter-clockwise to "ON".

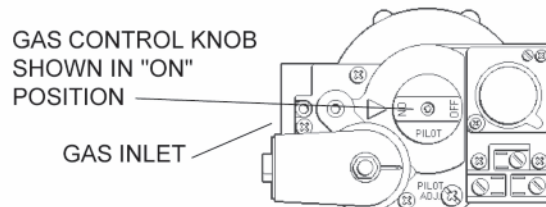

9. Replace boiler door panel.
10. Turn on all electrical power to the appliance.
11. Set thermostat to desired setting.
12. If the appliance will not operate, follow the instructions "To Turn Off Gas To Appliance" and call your service technician or gas supplier.

TO TURN OFF GAS TO APPLIANCE

1. Set the thermostat to the lowest setting.
2. Turn off all the electrical power to the appliance if service is to be performed.
3. Remove door panel.
4. **For Robertshaw gas valve:** Turn gas control knob clockwise to "OFF".
For Honeywell gas valve (all models except 40#): Turn gas control knob clockwise to "OFF".
For Honeywell gas valve (Models 40# only): Push in gas control knob slightly and turn clockwise to "OFF".
5. Replace heater door panel.

For Models with Automatic Gas Valves

Lighting Instructions

1. Close all gas valves. Turn off electrical power supply. Wait five (5) minutes.
2. Open manual pilot valve. Turn on electrical power. Pilot is automatically lighted.

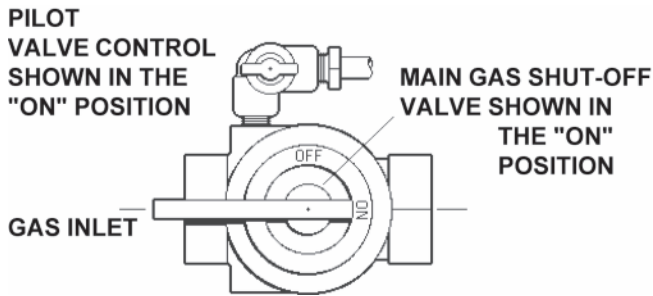

Fig. 40: Shut Off Valve

3. Open main gas valve.
4. Set temperature controls to desired temperature.

To Shut Down

Close all manual gas valves. Turn off electrical power.

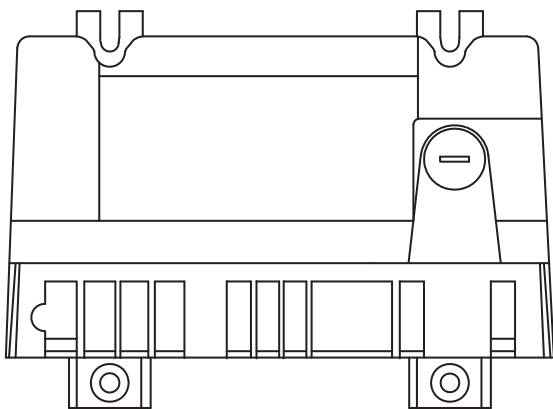

Fig. 41: Ignition Module

After Start-Up

Intermittent Pilot System IID

1. Turn on power to the ignition systems and turn gas supply off.

2. Check ignition module as follows:
 - a. Set the thermostat or controller above room temperature to call for heat.
 - b. Watch for continuous spark at the pilot burner.
 - c. Time the spark operation. Time must be within the lockout timing period (15 or 90 seconds).
 - d. Turn thermostat down to end call for heat and wait 60 seconds on lockout models before beginning step 3.
3. Turn on gas supply.
4. Set thermostat or controller above room temperature to call for heat.
5. Systems should start as follows:
 - a. Spark will turn on and pilot gas valve will open at once. Pilot burner should ignite after gas reaches the pilot burner.
 - b. Spark ignition should cut-off when pilot flame is established.
 - c. Main gas valve should open and main burner should ignite after gas reaches the burner port.

Inspections

Burners

Clean main burners and air louvers of dust, lint and debris. Keep boiler area clear and free from combustibles and flammable liquids. Do not obstruct the flow of combustion and ventilation air. Make visual check of burner and pilot flame. Yellow flame indicates clogging of air openings. Lifting or blowing flame indicates high gas pressure. Low flame indicates low gas pressure.

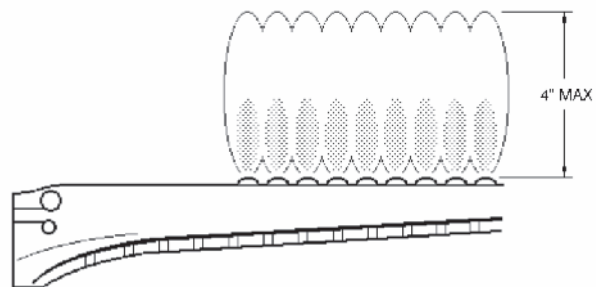

Modulating burner flame varies in height from approximately 1/4" at low fire to approximately 4" at high fire.

Fig. 42: Typical Main Burner Flame

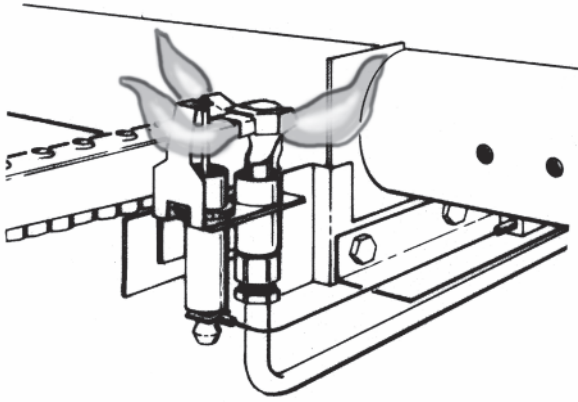

Fig. 43: Pilot Burner Flame (IID Units)

Controls

Check all controls to see that they are operational. To check electronic safety (IID Models), turn off main burner. Observe pilot burner when shutting off pilot gas. Ignition spark should go on. Main gas valve will also drop out.

To check high limit switch, turn dial setting down to a point slightly below the temperature of the water leaving the heater. The reset button should snap out and the burner should shut-off. Reset dial to 30°F to 40°F above desired operating temperature, and push reset button. Burner should light.

Suggested Inspection Schedule

The boiler should be inspected on the first and third months after initial start-up and then on an annual basis. If problems are found, refer to Troubleshooting Guide for additional directions.

1. Remove top of heater and inspect heat exchanger for soot and examine venting system.
2. Remove rear header and inspect for scale deposits, and/or accelerated erosion.
- *3. Inspect pilot and main burner flame and firing rate.
- *4. Inspect and operate all controls and gas valve.
- *5. Visually inspect system for water leaks.
- *6. a. Oil pump motor and bearing assembly, if oil cups are provided.
b. Disconnect pump from header and check condition of pump impeller. Check condition of bearing by attempting to move impeller from side to side. Replace any parts showing wear.
c. Check pump coupler for wear and vibration.
7. Check flow switch paddle.
8. Clean room air intake openings to ensure adequate flow of combustion and ventilation air.
9. Keep boiler area clear and free from combustible materials, gasoline, and other flammable vapors and liquids.

*Should be checked monthly. (Takes approximately 15 minutes).

LOW NOX BOILERS— Models 0181 to 0401

The boilers are certified and tested under the latest edition of the ANSI Z21.13 standards for hot water boilers.

CAUTION: Combustion air must not be contaminated by corrosive chemical fumes which can damage the boiler and void the warranty.

The boiler should be installed to meet the latest edition of all local codes, the National Fuel Gas Code Z223.1 and the National Electrical Code, ANSI/NFPA 70.

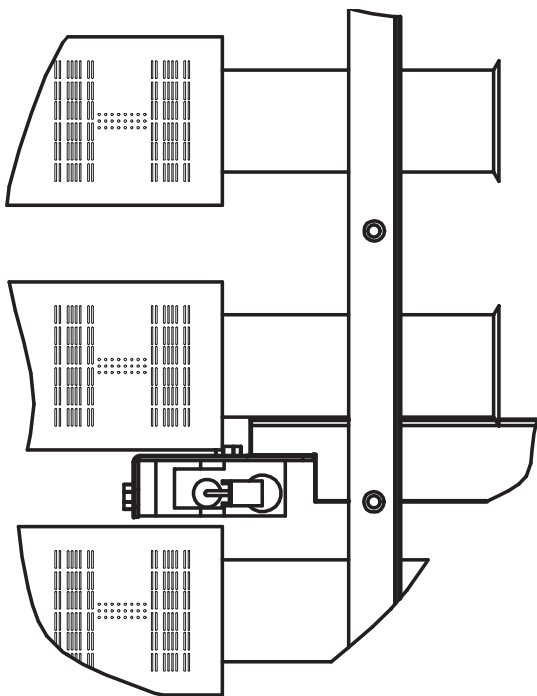

DETAIL A

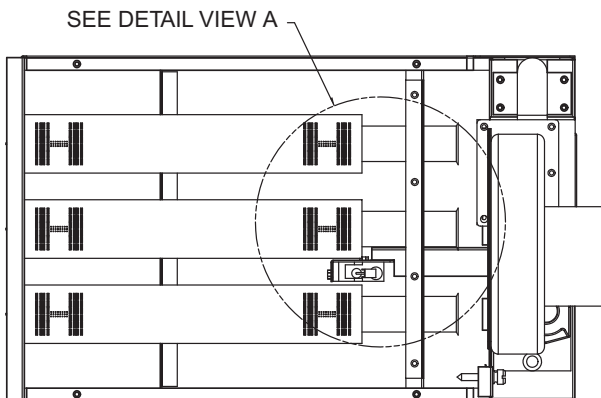

Fig. 44: Burner Detail

Operation

On call for heat, the ignition system, consisting of an electronic spark module, and gas pilot system is energized. Providing pilot is proven, blower will start running, the main gas valve will open and the boiler will operate. When the operating control is satisfied the boiler will shut down.

Start-Up IID

1. Turn on power to the boiler with gas supply off.
2. Check ignition module as follows:
 - a. Set the thermostat or controller to call for heat.
 - b. Watch for continuous spark at the pilot burner.
 - c. Check the ignition spark operation. Time must be within the lockout timing period (90 seconds).
 - d. Turn control down to end call for heat and wait 60 seconds before beginning step 3.
3. Turn on gas supply.
4. Set controller to call for heat.
5. System should start as follows:
 - a. Spark will turn on and pilot gas valve will open.
 - b. Main valve and blower will be powered after pilot flame signal is proven.
 - c. Heater will operate until call for heat is satisfied.

Blower Adjustment

The blower is set for optimal operation. If adjustment is needed, see Fig. 46.

Visual Inspection

Flame can be observed through the slot opening above the plenum. Flame color is blue and evenly spread on the top surface of the burner. At least every three months a visual inspection should be made of the burners. In case flame lifting is observed, check gas pressure on manifold and static pressure in plenum. Gas pressure in manifold should be 3.9" W.C. and static pressure in plenum should be greater than 0.5" W.C.

Electrical

Be sure that electrical service to the boiler has proper overload fuse or circuit breaker protection and wire

size, and connections which comply with all applicable codes.

Flame Roll-Out Safety Switch

The boiler is equipped with a cut-off device to prevent flame roll-out in the event the heat exchanger becomes blocked. This is a "manual reset" type roll-out switch, that must be reset by a service technician after any over temperature conditions have been fixed. Excessive restriction in the heat exchanger flue passage may cause the switch to disable the boiler.

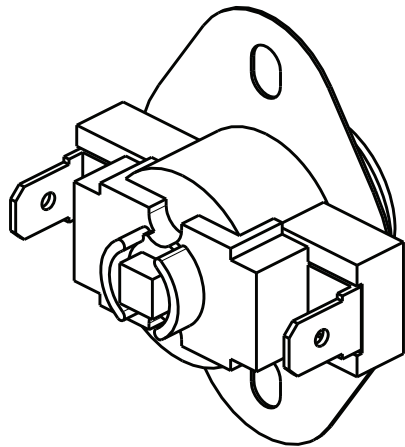

Fig. 45: Flame Roll-Out Safety Switch

Service

Burner Tray Removal

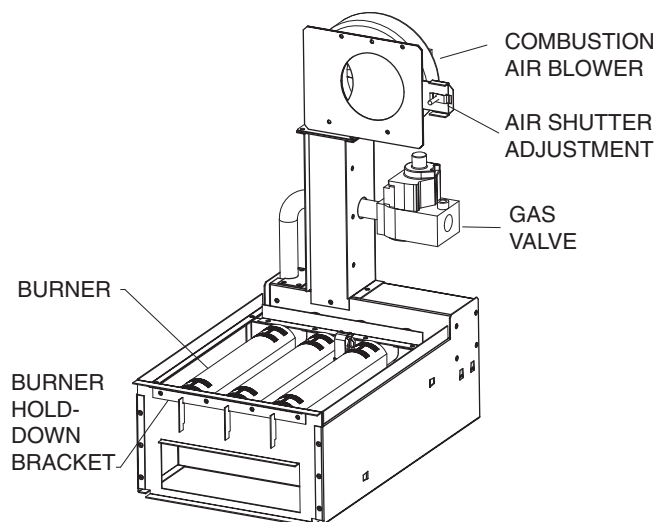

Fig. 46: Low NOx Burner Tray Assembly

1. Shut-off main electrical power switch to heater.
2. Shut-off gas upstream of heater.
3. Remove front door.
4. Disconnect gas line from gas valve.
5. Remove (2) screws that mount burner tray to the base of the unit, and (2) screws that secure gas valve to jacket.
6. Disconnect wires that terminate at gas valve.
7. Unscrew (4) screws that secure the control box.
8. Disconnect pilot wire from the ignition module.
9. Disconnect wire harness from the combustion blower.
10. Carefully slide out the burner tray assembly.
11. Reverse above procedure to re-install.

Gas Valve Adjustment - Robertshaw (Invensys) 7000 Series 2-Stage Gas Valve with Solenoid Valve, sizes 0181-0401 ONLY

NOTE: Attach a manometer and check the manifold pressures –both high fire and low fire– before making any adjustments.

1. Turn the heater off.
2. Remove the 3/8" nut or the #10 Torx screw.
3. Lift solenoid valve up, keeping the wires connected to the solenoid valve.
4. If only low fire adjustment is needed, go to Step 9.
5. Using a 3/8" wrench, carefully remove the aluminum cap that was under the solenoid valve-count # of turns when removing the cap. Be careful not to drop the cylinder (weight) or the small spring that is under the cap –see Fig. 47.
6. Remove the spring and store in a safe place.

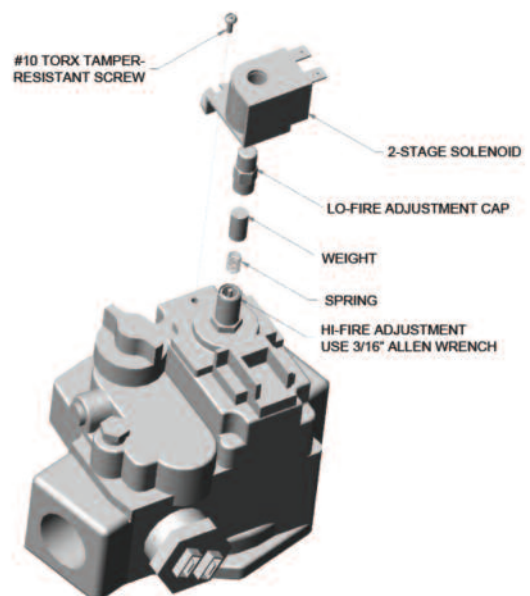

Fig. 47: 2-Stage Gas Valve Adjustment (Invensys)

7. Using an Allen wrench, turn the screw clockwise to increase or counterclockwise to decrease high fire manifold pressure –see Fig. 47.
8. Install the spring, weight and aluminum cap –tighten the cap using same # of turns as was used in removing the cap.
9. For low fire adjustment, tighten the aluminum cap to increase and loosen to decrease low fire manifold pressure.
10. Install 2-stage solenoid valve and turn heater on, check manifold pressures.
11. Repeat steps 3 to 10 until correct manifold pressures are obtained.
12. Secure 2-stage solenoid valve by tightening the 3/8" nut or #10 Torx screw.

Gas Valve Removal

1. Remove burner tray. See Burner Tray Removal procedure.
2. Disconnect, pilot tubing from gas valve.
3. Turn vertical gas pipe from manifold slightly and unscrew gas valve.
4. Reverse above procedure to re-install.

Main Burner and Orifice Removal

1. Remove burner tray. See Burner Tray Removal procedure.
2. Remove pilot. See Pilot Removal procedure.
3. Remove (8) total screws from the hold-down brackets, front and rear of tray.
4. Remove (8) total screws from the left and right sides of the manifold assembly. Detach the manifold assembly from the burner tray assembly.
5. Remove burners by raising the bracket on the back end of the burners up and out of their slots.
6. Use a long 1/2" socket wrench to remove orifices from the gas manifold.
7. Remove burners by raising the bracket on the back end of the burners up and out of their slots.
8. Reverse above procedure to re-install.

Pilot Removal

1. Disconnect pilot tubing from gas valve.
2. Remove (4) screws from control box. Open the control box.
3. Remove the pilot wire from the ignition wire.
4. Remove (2) screws that mount the pilot bracket to the air manifold assembly.

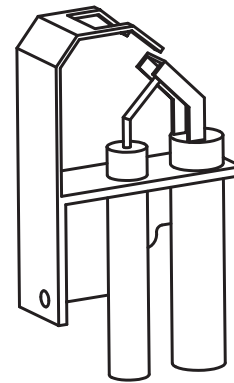

Fig. 48: IID Pilot

5. Pull the pilot bracket slightly, then drop and pull downwards and outwards.
6. Reverse above procedure to re-install. Make sure the pilot bracket is all the way up on the pilot side, see drawing below.

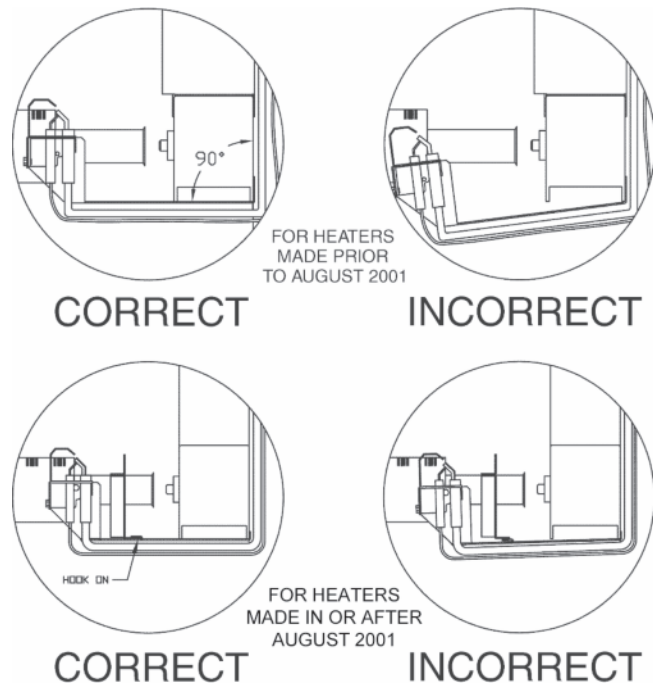

Fig. 49: Pilot Removal

Combustion Fan Removal

1. Remove burner tray. See Burner Tray Removal procedure.
2. Remove (4) screws that mount the combustion blower to the manifold assembly.
3. Reverse above procedure to re-install.

TROUBLESHOOTING

WARNING—HIGH VOLTAGE: For qualified technicians ONLY.

Electrical—Electronic Ignition IID

NOTE: Some heaters may be equipped with an ignition module that shuts off pilot gas if pilot fails to light. To reset, interrupt power to heater.

Intermittent Pilot System Honeywell S8600

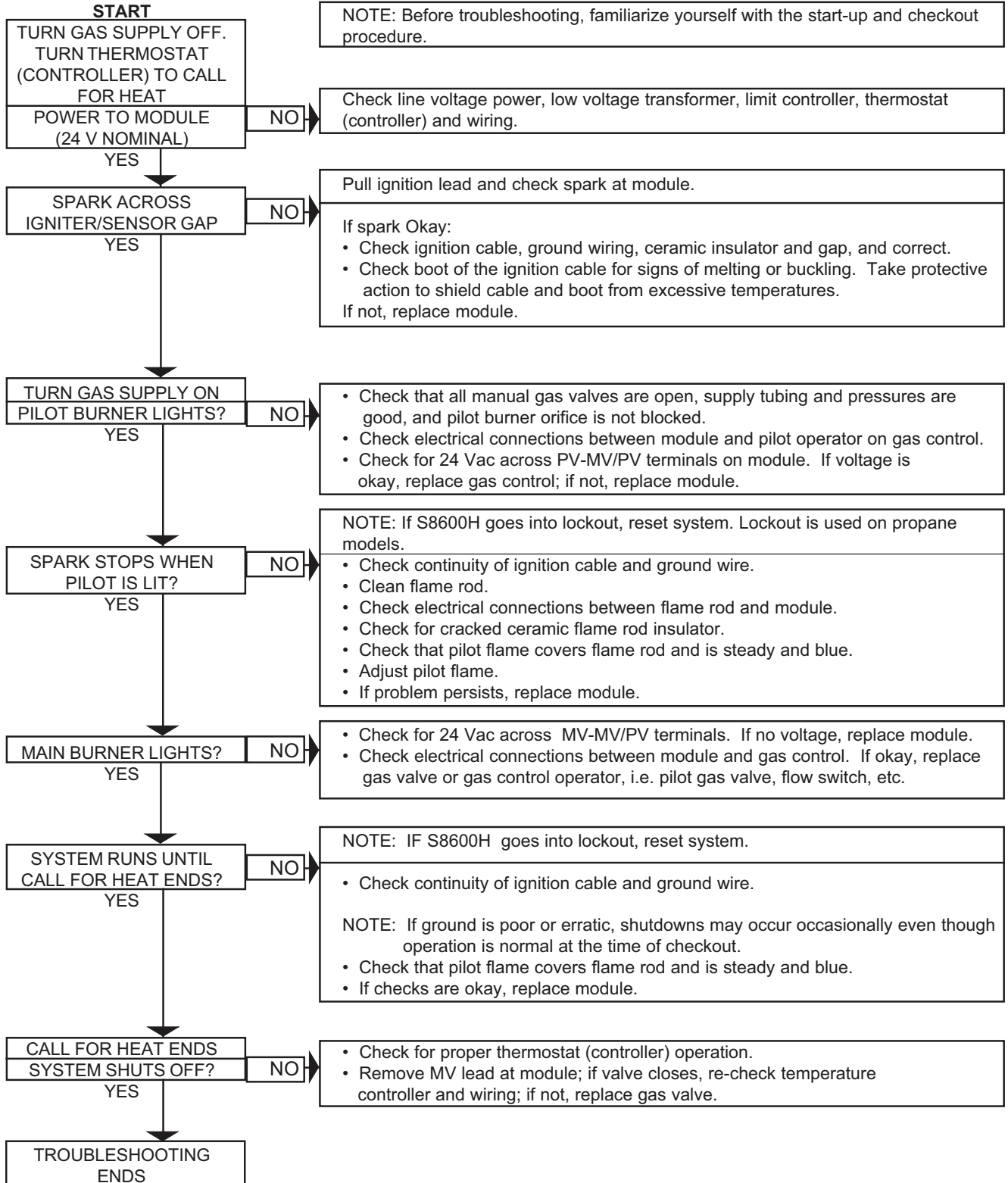

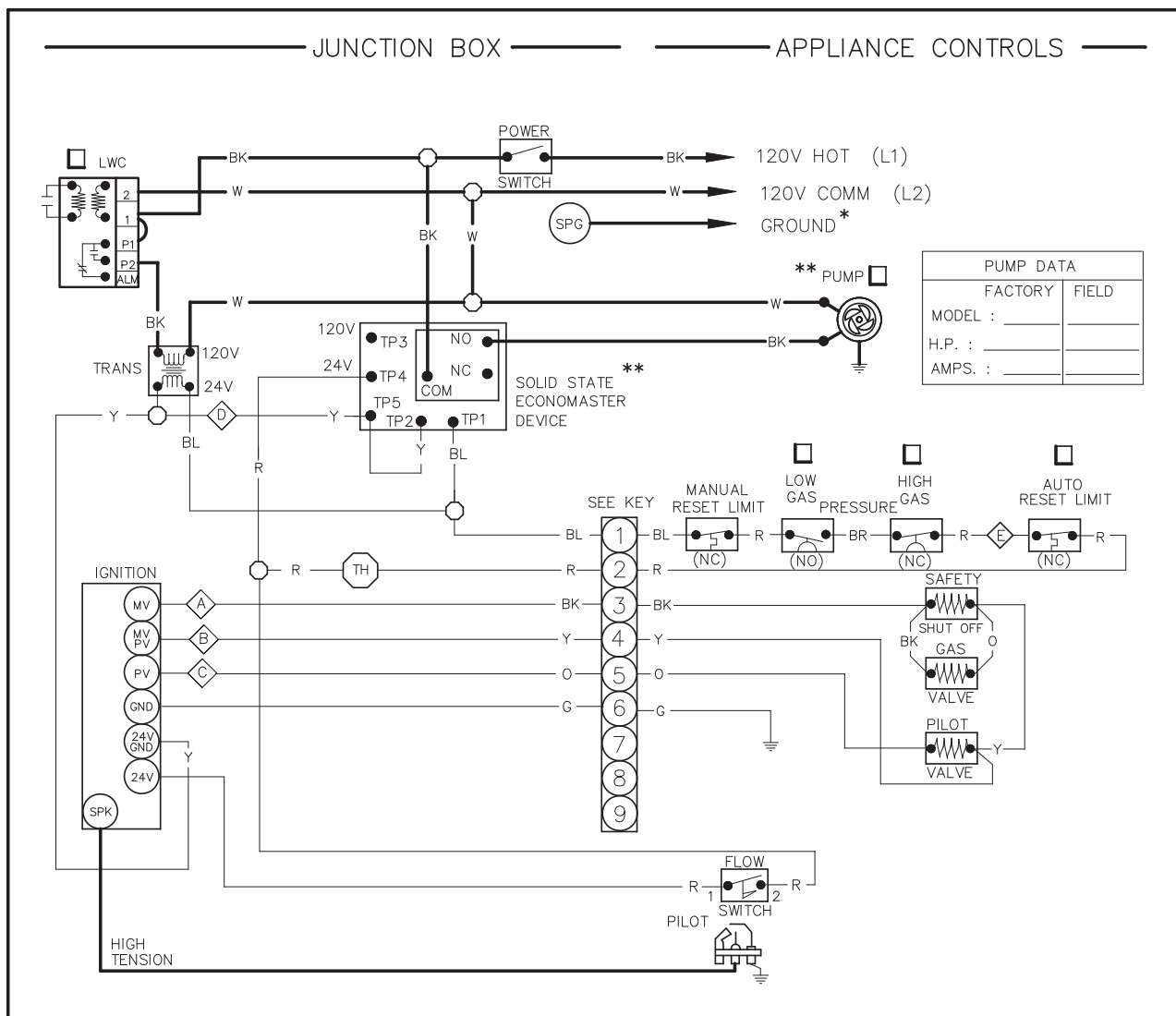

PUMP DATA	
FACTORY	FIELD
MODEL :	
H.P. :	
AMPS. :	

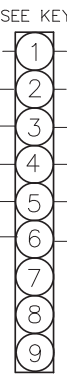

KEY	
	24V 105°C
	120V 105°C
	WIRE NUT
	GROUND
BK	BLACK
BR	BROWN
R	RED
O	ORANGE
Y	YELLOW
G	GREEN
BL	BLUE
V	VIOLET
W	WHITE
PLUG (ACTUAL)	
FRONT VIEW	

NOTES: * USE GROUND CONNECTION PROVIDED. FAILURE TO PROVIDE PROPER GROUND MAY RESULT IN LOCK-OUT ALL GROUND \perp TERMINATE AT .

****** PUMP USED MUST BE RATED 10 AMPS MAX OR 3/4 HP MAX. PUMP DELAY ADJUSTABLE BETWEEN 3 AND 10 MINUTES.
 - CONNECTIONS FOR OPTIONAL E-4 ALARM PANEL.
 CHECK CONTROLS PROVIDED (WIRED AS SHOWN) REPLACE WIRING WITH 105°C WIRE ONLY

APPROVED BY:	
CHECKED BY:	
ORIG E.O. 2397	
07/08/88	
CHG E.O. 5223	
4/23/14	

WIRING DIAGRAM IID/ECONOMASTER FIRING MODE - ON/OFF	
BOILER INPUTS: 825,000 THRU 1,826,000 BTUH	
BOILER SIZE: 824-1826	BOILER TYPE: H4/W1
152170	7

**TYPICAL ON-OFF INTERMITTENT IGNITION
CONTROL WIRING DIAGRAM**

MECHANICAL PROBLEM	POSSIBLE CAUSE	CORRECTIVE ACTION
When boiler is turned on nothing happens.	No power to the boiler.....	Check the circuit breaker, outdoor controller, etc., upstream of boiler.
	Bad transformer.....	If power to Leads L1 and L2 of transformer, but no power on 24V side, replace.
	Inoperative thermostat.....	Jumper thermostat. Replace with new if boiler fires. DO NOT leave thermostat jumpered.
	Inoperative toggle switch.....	If power to toggle switch, but not through switch, replace.
	Inoperative relay.....	If power to relay, but not operating, replace.
Thermostat in "ON" position causes relay and pump to operate, but boiler does not fire.	Main gas valve is closed.....	Open valve.
	Plugged bleed line on gas valve or gas pressure regulator.....	Loosen bleed line and clean.
	Broken pump coupler.....	Replace coupler. Inspect bearing assembly, and if frozen, lubricate or replace.
	Shutdown by low water cut-off, caused by air.....	Bleed air from system.
	Gas valve defective.....	Check for power to gas valve. If valve has power but will not open, check vent tube for blockage. If clear, replace valve.
Continuous shut down of manual reset high limit.	Temperature setting too low.....	Reset high limit to higher temperature.
	Low water flow.....	Check all pumps.
	Interrupted pump operation.....	Check pump oil if necessary.
	Modulating control set too high.....	Reset modulator to a lower setting.
	Mechanical modulating control.....	Check and replace if necessary.
Sooting CAUTION-Soot may be combustible. Wet down and exercise caution when cleaning.	Air starvation.....	Refer to installation instructions regarding combustion air requirements.
	Condensation..... Toxic fumes which cause a chemical reaction with copper tubes or destroy combustion.....	Set bypass valve to prevent boiler inlet temperature from dropping below 105 °F. Remove all sources of fumes, such as freon, chloride, or isolate the boiler.
	Improper venting.....	Follow recommended vent installation instructions.
Continuous shut down of low water cut-off or flow switch.	Insufficient flow.....	Check pumps and piping.
	Low water due to leaking.....	Inspect for leakage and repair.
	Air in system.....	Inspect for leakage and repair. Install an automatic air vent.
	Line strainer dirty..... Lime in heat exchanger.....	Clean. Ream tubes.
Low flame.	Gas supply.....	Debris in gas line (pipe dope, rocks, etc.). Gas line too small. Improperly sized gas meter. Gas regulator adjustment.
	Insects or debris clogging burners.....	Clean burners.
	Burner intake ports low gas pressure....	Adjust gas pressure.
	Venting or combustion air.....	Refer to installation instructions regarding combustion air requirement.
Outer jacket very hot (blistered paint).	Broken refractory.....	Replace refractory panels.

Pumps

Failure To Pump

1. Pump not properly primed.
2. Wrong direction of rotation.
3. Speed too low.
4. Total head too high.

Reduced Capacity And/Or Head

1. Air pockets or leaks in suction line.
2. Clogged impeller.
3. Foot valve strainer too small or clogged.
4. Excessive suction lift (over 15 ft.).
5. Insufficient positive suction head (for hot water).
6. Total head more than that for which pump is intended.
7. Excessively worn impeller and wearing rings.

Rapid Wear Of Coupling

1. Misalignment or a bent shaft.
2. Sagging motor mounts (over-oiling).

Pump Loses Prime

1. Air leaks in suction line.
2. Excessive amount of air in water.
3. Water seal in stuffing box not functioning.
4. Excessive suction lift and pump operating too near shut-off point.

Overloaded Driving Unit

1. Head much lower than that for which pump is designed.
2. Speed too high or higher than that contemplated.

Mechanical Troubles and Noise

1. Misalignment.
2. Excessive suction lift or vapor binding (hot water).
3. Bent shaft and/or damaged bearings.
4. Suction and discharge piping not properly supported and anchored.

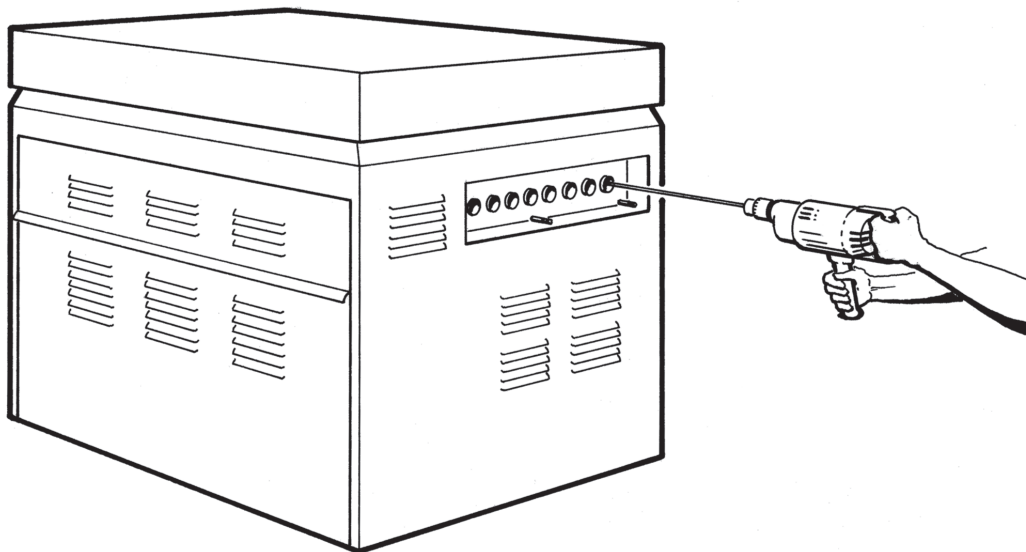

Fig. 50: Tube Cleaning Procedure

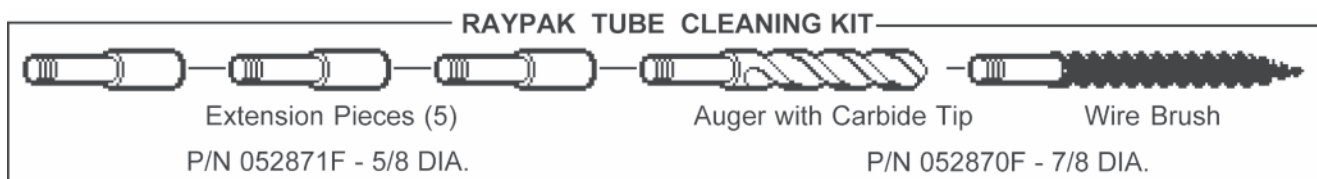

Fig. 51: Raypak Tube Cleaning Kit

Service

Repair Section

Tube Cleaning Procedure

Establish a regular inspection schedule, the frequency depending on the local water condition and severity of service. Do not let the tubes clog up solidly. Clean out deposits over 1/16" in thickness.

The boiler may be cleaned from the side opposite the water connections as shown, without breaking pipe connections. It is preferable, however, to remove both headers for better visibility through the tubes and to be sure the residue does not get into the system.

Note that you do not remove the top pan or the heat exchanger generally. After reaming with the auger, mount the wire brush and clean out the debris remaining in the tubes. Another method is to remove the heat exchanger, ream tubes and immerse heat exchanger in noninhibited de-scale solvent.

Burner Tray Removal

1. Shut-off power and gas supply to the boiler. Disconnect union(s) and pilot tubing, then loosen and remove burner hold-down screws.
2. Disconnect wires at gas valve and slide burner tray out.

Gas Valve Removal

1. Shut-off gas supply to the boiler. Remove gas piping to gas valve inlet.
2. Disconnect wires, pilot tubing and bleed line, if required.
3. Turn vertical gas pipe from manifold slightly and unscrew gas valve.
4. Reverse above procedure to re-install.

Main Burner And Orifice Removal

1. Remove screws and burner hold-down bracket.

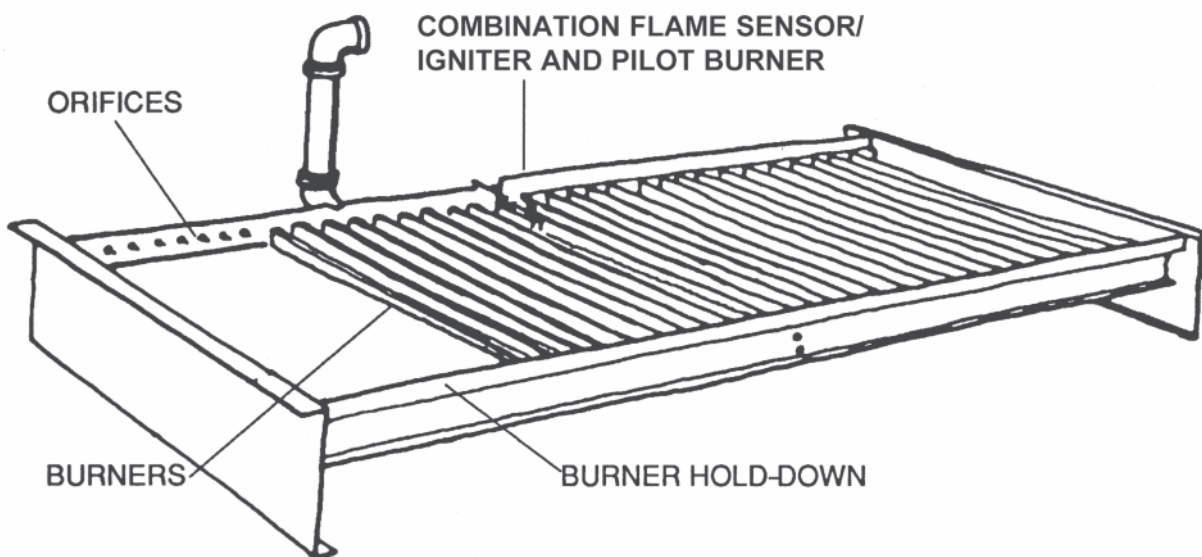

Fig. 52: Typical Burner Tray Illustrated

NOTE: If the heat exchanger is sooted badly, the burner hold-down bracket and spacer can become distorted from direct flame impingement and this usually necessitates replacement of these parts.

2. Lift burners from slotted spacer and slide from orifices. Clean with a wire brush.
3. Clean orifice(s) as necessary.

Pilot Removal and Cleaning

1. Disconnect pilot tubing at pilot and sensor/igniter wire. Remove screws holding pilot bracket to burner tray.
2. Remove pilot and bracket, clean pilot of debris, small bugs, etc., with wire or small brush.
3. Replace pilot, pilot tubing, sensor ignition wires and check for leaks.

High Limit or Tankstat Removal

1. Turn off electrical power.

2. Remove front inspection panel.
3. Remove wires to high limit and loosen screws holding high limit to cabinet.
4. Remove wedge clip holding sensing bulb in control well.
5. Remove high limit and install a new one.
6. Check control operation before leaving job.

Heat Exchanger Removal

1. Shut water, gas and electricity off, close valves and relieve pressure, remove relief valve. Remove side inspection panels.
2. Remove top holding screws.
3. Remove draft diverter, lift and remove top and flue collector on stack type models. Remove inspection panels.
4. Loosen bolts and disconnect flange nuts on in/out header, loosen union(s) at gas pipe, and slide boiler away from piping until studs clear the heater.

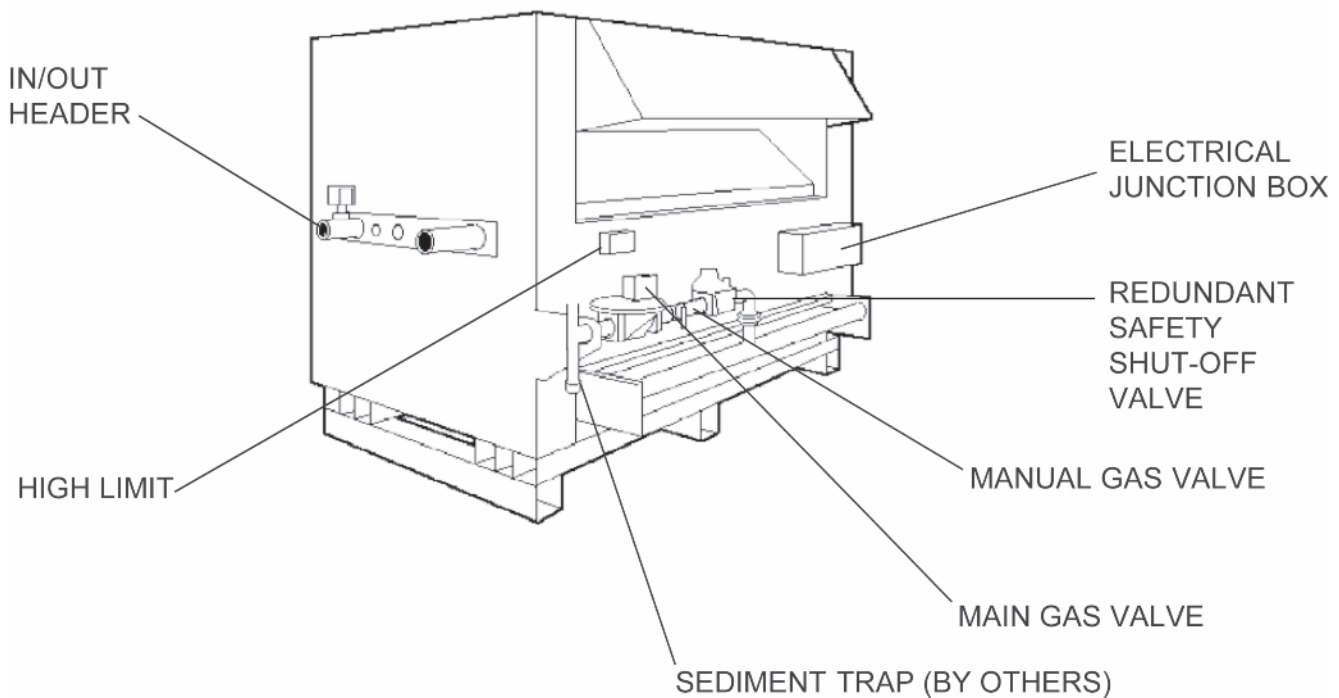

Fig. 53: Model 2100-4001 Boiler Illustration

5. Remove heat exchanger corner brackets.
6. Remove combustion chamber clips at the four corners of the heat exchanger.
7. Lift heat exchanger straight up using caution not to damage refractory.

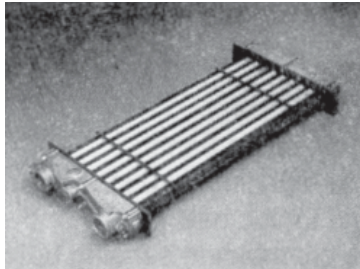

Fig. 54: Heat Exchanger

Heat Exchanger Re-Assembly

1. Heat exchanger water header O-rings should be replaced with new ones.
2. Install in/out and return water headers and install header retainer nuts and torque nuts evenly.
3. Install the four (4) corner clips between tube sheets and refractory. Replace "V" baffles.
4. Install thermostat sensing bulbs in header wells and replace bulb retaining clips.
5. Install inlet and return pipes in water headers using pipe thread sealant.
6. Install water pressure relief valve, flow switch, and low water cut-off devices if so equipped.
7. Open water supply and return shut-off valves. Fill boiler and water piping system with water. Check boiler and piping system for leaks at full line pressure. Run system circulating pump for a minimum of 1/2 hour with boiler off.
8. Shut down entire system and vent all radiation units and high points in system piping. Check all strainers for debris. Expansion tank water level should be at the 1/4 mark and the balance of the tank filled with air.
9. Install flue collector, jacket top and inspection panels. Install top holding screws. Install draft diverter and vent piping if so equipped.
10. If gas piping was disconnected, reconnect gas piping system and check for leakage using a soapy

solution.

11. Check for correct water pressure and water level in the system. Make sure that system pump operates immediately on the call for heat. The system is ready for operation.
12. Within two (2) days of start-up, recheck all air vents and expansion tank levels.

Combustion Chamber Removal

To remove combustion chamber you must first remove the heat exchanger. Unbolt metal combustion chamber retainer from top and remove combustion chamber panels individually.

Control Well Replacement

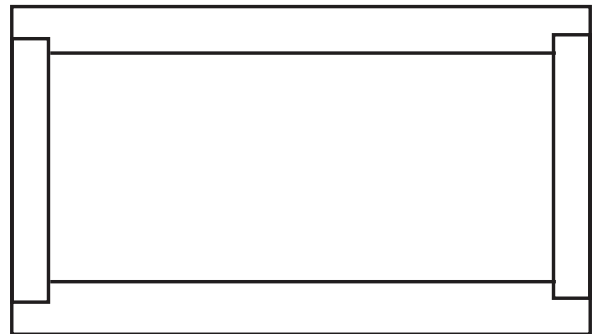

Fig. 55: Refractory Panels—Top View

Remove top, sensing bulb and clip. Collapse well tube at the opening with a chisel, push through into header and remove the well through header. Insert a new well and roll into place. If a roller is not available, solder the well in place with silver solder.

Tube Replacement Procedure

1. Remove heat exchanger from boiler following instructions outlined under HEAT EXCHANGER REMOVAL above.
2. Remove in/out and return headers. Remove "V" baffle from damaged tube.
3. Remove damaged tube by cutting with a hack saw or shearing with a chisel adjacent to each tube sheet.
4. Collapse stub ends in tube sheets using a chisel or screwdriver. DO NOT cut into tube sheet or mar surface in tube hole in any way.
5. Insert replacement tube by inserting the end with the most fins removed in the opening of one tube

sheet. Slide tube until the opposite end clears the other tube sheet and fit the tube into the hole.

6. Insert the tube roller into tube opening up to stop, making certain that 1/8" of tube projects beyond the tube sheet.
7. Attach drill to tube roller, holding it straight and level.
8. Reverse drill motor and withdraw tube roller. If necessary wrench out by hand.

NOTE: Use a 3/8" heavy duty, reversible, electric drill or larger. Proceed to expand tube until tool starts to grab. Approximately 1/2 to 1" of the tool shank will be visible.

9. DO NOT apply excessive torque during rolling operation and avoid thinning any wall of the tube beyond 0.015".
10. Use same procedure on opposite end.
11. Apply line pressure test. Re-roll if necessary.
12. Reinstall as outlined under HEAT EXCHANGER RE-ASSEMBLY.

Cleaning Flue Gas Passageways

Soot will clog areas behind fins and cause eventual tube failure. Any sign of soot at base of burners or around outer jacket indicates a need for cleaning.

1. Lift off draft hood and flue collector by removing bolts and screws.
2. Remove "V" baffles from heat exchanger.
3. Remove burner tray.
4. Take garden hose and wash heat exchanger, making sure soot is removed from between fins. (Avoid excessive water against refractory).
5. Reassemble; when boiler is fired, some steam will form from wet refractory. This is normal.
6. Correct reason for soot formation.

NOTE: In extreme cases it may be necessary to remove the heat exchanger completely for cleaning. The simplest method is steam cleaning at a local car wash. DO NOT WIRE BRUSH!

CAUTION: Soot is combustible, so exercise extreme care.

REPLACEMENT PARTS

See separate parts sheet in instruction envelope.

NOTE: To supply the correct part it is important that you supply the model number, serial number and type of gas when applicable.

Any part returned for replacement under standard company warranties must be properly tagged with Raypak return parts tag, completely filled in with the heater serial number, model number, etc., and shipped to Raypak freight prepaid. If determined defective by Raypak and within warranty, the part will be returned in kind or equal substitution, freight collect. Credit will not be issued.

RAYPAK, INC.
2151 Eastman Avenue
Oxnard, CA 93030

**LIMITED WARRANTY
RAYTHERM - TYPES H AND WH
Models: 0181-4001**

SCOPE

Raypak, Inc. (Raypak) warrants to the original owner that all parts of this heater which are actually manufactured by Raypak will be free from defects in materials and workmanship under normal use and service for the specified warranty periods and subject to the conditions set forth in this Limited Warranty. Labor charges and other costs for parts removal or reinstallation, shipping and transportation are not covered by this Limited Warranty, but are the owner's responsibility.

EFFECTIVE DATE

The Effective Date of this Limited Warranty is the date of original installation if properly documented; if you are not able to provide documentary proof of the date of original installation, the Effective Date will be the date of manufacture plus 30 days.

HEAT EXCHANGER WARRANTY PERIODS

Domestic Hot Water

Five (5) years from Effective Date. Includes copper heat exchanger with bronze or cast iron waterways.

Ten (10) years from Effective Date. Includes only cupro-nickel heat exchanger with bronze or cast iron waterways.

Space Heating (Closed Loop System)

Ten (10) years from Effective Date. Includes both cupro-nickel and copper heat exchanger with bronze or cast iron waterways.

Thermal Shock Limited Warranty

Twenty five(25) years from Effective Date against "Thermal Shock" (excluded, however, if caused by heater operation at large changes exceeding 150°F between the water temperature at intake and heater temperature, or operating at heater temperatures exceeding 240°F).

ANY OTHER PART MANUFACTURED BY RAYPAK

One (1) year from Effective Date.

THIS LIMITED WARRANTY WILL BE VOID IF THE HEATER RATING PLATE IS ALTERED OR REMOVED.

ADDITIONAL WARRANTY EXCLUSIONS

This Limited Warranty does **NOT** cover units moved from their original installation location or conditions including failures or malfunctions resulting from:

1. Failure to properly install, operate or maintain the heater in accordance with our printed instructions provided;
2. Abuse, misuse, alteration, accident, fire, flood and the like;
3. Sediment or lime build-up, freezing, or other conditions causing inadequate water circulation;
4. High velocity flow exceeding heater design rates;
5. Failure of connected systems devices, such as pump or controller;
6. Use of non-factory authorized accessories or other components in conjunction with the heater system;
7. Failing to eliminate air from, or replenish water in, the connected water system;
8. Chemical contamination of combustion air.

REPAIR OR REPLACEMENT

At its option, Raypak will repair or replace a defective part(s) in accordance with the terms of this Limited Warranty, if it fails in normal use and service during its specified warranty period. The failed part must first be returned to Raypak if requested, with transportation charges prepaid, and all applicable warranty conditions found satisfied. The repair or replacement part will be warranted for only the unexpired portion of the original Limited Warranty. Raypak makes no warranty whatsoever on parts not manufactured by it, but Raypak will apply any such warranty as may be provided to it by the parts manufacturer.

HOW TO MAKE A WARRANTY CLAIM

You should immediately notify the original installer, supplying the model number and serial numbers of the unit, date of installation and description of the problem. The installer must then notify his Raypak distributor for instructions regarding the claim. If either is not available please contact Service Manager, Raypak, Inc. 2151 Eastman Avenue, Oxnard CA 93030 or call (805) 278-5300. In all cases proper authorization must first be received from Raypak before repair or replacement of any part.

EXCLUSIVE WARRANTY-LIMITATION OF LIABILITY

The Limited Warranty is the only warranty for this product and its component parts given by Raypak. No one is authorized to make any other warranties on Raypak's behalf. **ANY IMPLIED WARRANTIES, INCLUDING MERCHANTABILITY OR FITNESS FOR A PARTICULAR PURPOSE, SHALL NOT EXTEND BEYOND THE APPLICABLE WARRANTY PERIODS SPECIFIED IN THIS LIMITED WARRANTY. RAYPAK'S SOLE LIABILITY WITH RESPECT TO ANY DEFECT SHALL BE AS SET FORTH IN THIS LIMITED WARRANTY. IT IS AGREED THAT RAYPAK SHALL HAVE NO LIABILITY WHETHER UNDER THIS LIMITED WARRANTY OR IN CONTRACT, TORT OR NEGLIGENCE OR OTHERWISE FOR CLAIMS FOR SPECIAL, INCIDENTAL OR CONSEQUENTIAL DAMAGES (INCLUDING NO LIABILITY FOR DAMAGE FROM WATER LEAKAGE) WHICH ARE EXPRESSLY EXCLUDED, NOTWITHSTANDING ANY FAILURE OF ESSENTIAL PURPOSE OF ANY LIMITED REMEDY.** Some states do not allow limitations on how long an implied warranty lasts, or for the exclusion of incidental or consequential damages, so the above limitation or exclusion may not apply to you. **THIS LIMITED WARRANTY GIVES YOU SPECIFIC LEGAL RIGHTS, AND YOU MAY ALSO HAVE OTHER RIGHTS WHICH VARY FROM STATE TO STATE.**

We suggest you immediately record the model and serial number and date of original installation and retain this Limited Warranty Certificate along with your original proof of purchase and date of installation/start-up in the event warranty service is needed.

DO NOT RETURN THIS DOCUMENT TO RAYPAK. KEEP IT WITH YOUR HEATER OR BUSINESS RECORDS.

Name of Owner	Name of Installer
Owners Address	Telephone Number of Installer
Date of Installation	Installation Site
Model Number	Serial Number

START-UP CHECKLIST FOR RAYPAK PRODUCTS ATMOSPHERIC

This start-up checklist is to be completely filled out by the service technician starting up the Raypak Boiler or heater for the first time. All information will be used for warranty purposes and to insure that the installation is correct. Additionally this form will be used to record all equipment operation functions and required settings.

GAS SUPPLY DATA

Gas Meter Size _____ CFH
 Gas Line Size _____ In. NPT
 Length of Gas Line _____
 Low Gas Pressure Setting _____ In. WC
 High Gas Pressure Setting _____ In. WC
 Gas Valve Type _____

CLEARANCES

Front Clearance _____ In.
 Right Side Clearance _____ In.
 Left Side Clearance _____ In.
 Rear Clearance _____ In.
 Overhead Clearance _____ In.

ELECTRICAL

Voltage Supply/Control _____
 Auto High Limit Setting _____
 Manual Reset High Limit _____
 Ignition Control: S8600 _____ Other _____
 Is unit grounded ___ Yes ___ No
 Temp Control Setting _____ Deg

VISUAL INSPECTION OF COMPONENTS

Wiring Harness _____
 Pilot Assembly _____
 Burner/s _____
 Refractory _____
 Remote (if applicable) _____

WATER SUPPLY

Flow Rate in GPM or Delta T _____ If Avail
 Pump Economaster setting _____ Min
 Low Water Cutoff _____ Test
 Number of Tanks and Size _____
 Pressure Switch _____
 Plumbing Size _____ Inches
 Pump Size: _____ Pump HP: _____

VENTING

Vent Size: _____ Stack Height: _____
 Vent Category: _____
 Vent Material: _____
 Vent Termination Type: _____
 Combustion Air Openings: _____ Sq. In.

Model Number: _____ Serial Number: _____

Job Name _____

Address _____

Physical Location of Boiler: Indoors ___; Outdoors ___; Ground Level ___; Roof ___; Below Grade ___

Mechanical Contractor/Installer _____

Date and Time of Start-up _____ Print Name _____

Signature of Startup Technician _____



www.raypak.com

Raypak, Inc., 2151 Eastman Avenue, Oxnard, CA 93030 (805) 278-5300 Fax (805) 278-5468
Litho in U.S.A.