

INSTALLATION & OPERATING INSTRUCTIONS

Raytherm® Hot Water Supply Heaters



**Models 0133–4001
Type WH**



WARNING: Improper installation, adjustment, alteration, service or maintenance can cause property damage, personal injury or loss of life. Refer to this manual. Installation and service must be performed by a qualified installer, service agency or the gas supplier.

FOR YOUR SAFETY: Do not store or use gasoline or other flammable vapors and liquids or other combustible materials in the vicinity of this or any other appliance. To do so may result in an explosion or fire.

WHAT TO DO IF YOU SMELL GAS:

- Do not try to light any appliance.
- Do not touch any electrical switch; do not use any phone in your building.
- Immediately call your gas supplier from a neighbor's phone. Follow the gas supplier's instructions.
- If you cannot reach your gas supplier, call the fire department.

Installation and service must be performed by a qualified installer, service agency or the gas supplier.

This manual should be maintained in legible condition and kept adjacent to the heater or in a safe place for future reference.

Raypak®
A Rheem® Company

Rev. 16 reflects the following:

Changes to: ASME Mark on page 1, warnings on page 4, warning on page 27

Additions: Warnings on page 7, warning on page 13, warnings on page 14, warning on page 19, caution on page 20, warning on page 30, warning on page 48

CONTENTS

WARNINGS	4	Burner Adjustment	34
Pay Attention to These Terms	4	Visual Inspection	34
GENERAL SAFETY	5	Electrical	34
Time/Temperature Relationships in Scalds	6	High Gas Pressure Switch	34
RECEIVING EQUIPMENT	6	Burner Tray Removal	34
Model Identification	6	Gas Valve Removal	34
General Specifications	7	Main Burner And Orifice Removal	35
All Models (Approved)	7	Pilot Removal	35
Hot Water Supply Heaters	7	Combustion Fan Removal	35
INSTALLATION	7	TROUBLESHOOTING	36
Installation Codes	7	Electrical	36
Installation Base	7	Mechanical	37
Clearances	8	WIRING DIAGRAMS	38
Specifications and Dimensions	9	Wiring Diagram—W2/WH2 133	38
Outdoor Water Heaters	12	Wiring Diagram—WH1 0181/0261	39
Combustion Air (Indoor Units Only) Air for		Wiring Diagram—WH1 0331/0401	40
Combustion and Ventilation	12	Wiring Diagram—WH1 0514–0724	41
Venting	13	Wiring Diagram—WH1 0824–1826	42
Vent Piping	17	Wiring Diagram—WH1 2100–2500	43
Vent Damper Installation	18	Wiring Diagram—WH1 3001–4001	44
Plumbing	20	Troubleshooting—Pumps	45
Flow Rates	22	SERVICE AND MAINTENANCE	
Piping—Domestic Hot Water Supply		PROCEDURES	45
Heaters	23	Tube Cleaning	45
Piping Diagram—Type WH - Unitemp 80		Burner Tray Removal	46
System	24	Gas Valve Removal	46
Controls—General	25	Gas Valve Adjustment - Robertshaw	
Limit Controls	26	(Invensys) 7000 Series 2-Stage Gas Valve	
Electrical Connections	27	with Solenoid Valve	46
Location of Controls	28	Main Burner and Orifice Removal	47
START-UP PROCEDURES	30	Pilot Removal and Cleaning	47
Before Start-Up	30	High Limit or Tankstat Removal	47
General	30	Heat Exchanger Removal	47
Initial Start-Up - Pump and Motor	30	Heat Exchanger Re-Assembly	47
Intermittent Pilot System Checkout		Combustion Chamber Removal	48
Procedure (S8600)	32	Control Well Replacement	48
INSPECTION PROCEDURES	32	Tube Replacement	48
Burners	32	Cleaning Flue Gas Passageways	49
Controls	32	REPLACEMENT PARTS	49
Inspection Procedures	33	WARRANTY	50
ADDENDA: LOW NO_x HEATERS			
Models 0181 to 0401	33		
Operation	33		
Start-Up Procedures			
(S8610B Ignition Module)	33		

WARNINGS—Pay Attention to These Terms

DANGER:	Indicates the presence of immediate hazards which will cause severe personal injury, death or substantial property damage if ignored.
WARNING:	Indicates the presence of hazards or unsafe practices which could cause severe personal injury, death or substantial property damage if ignored.
CAUTION:	Indicates the presence of hazards or unsafe practices which could cause minor personal injury or product or property damage if ignored.
NOTE:	Indicates special instructions on installation, operation, or maintenance which are important but not related to personal injury hazards.

DANGER: Failure to install the draft hood and properly vent the water heater to the outdoors as outlined in the Venting section of this manual can result in unsafe operation of the water heater. To avoid the risk of fire, explosion, or asphyxiation from carbon monoxide, never operate this water heater unless it is properly vented and has an adequate air supply for proper operation. Be sure to inspect the vent system for proper installation at initial start-up; and at least annually thereafter. Refer to the Maintenance section of this manual for more information regarding vent system inspections.

DANGER: Make sure the gas on which the heater will operate is the same type as that specified on the heater rating plate.

DANGER: When servicing or replacing components that are in direct contact with the water, be certain that:

- There is no pressure in the heater. (Pull the release on the relief valve. Do not depend on the pressure gauge reading).
- The heater water is not hot.
- The electrical power is off.

WARNING: Risk of electrical shock. More than one disconnect switch may be required to de-energize the equipment before servicing.

WARNING: All venting types must be of the same material or product throughout the entire exhaust installation to ensure proper securing and sealing.

WARNING: Should overheating occur or the gas supply valve fail to shut, do not turn off or disconnect the electrical supply to the heater. Instead, shut off the gas supply at a location external to the heater.

WARNING: Both propane and natural gas have an odorant added to help detection. Some people may not physically be able to smell or recognize this odorant. If unsure or unfamiliar about the smell associated with propane or natural gas, ask the gas supplier. Other conditions, such as "Odorant Fade", which causes the odorant to "fade", or diminish in intensity can also hide or camouflage a gas leak.

WARNING: UL recognized fuel gas detectors are recommended in all enclosed propane and natural gas applications wherein there is a potential for an explosive mixture of fuel gas to accumulate and their installation should be in accordance with the detector manufacturer's recommendations and/or local laws, rules, regulations, or customs.

WARNING: Do not use this heater if any part has been under water. Immediately call a qualified service technician to inspect the heater and to replace any part of the control system and any gas control which has been under water.

WARNING: Altering any Raypak pressure vessel by installing replacement heat exchangers, tube bundle headers, or any ASME parts not manufactured and/or approved by Raypak will instantly void the ASME and/or CSA ratings of the vessel and any Raypak warranty on the vessel. Altering the ASME and/or CSA ratings of the vessel also violates national, state, and local approval codes.

WARNING: Propane appliances should not be installed below-grade (for example, in a basement) if such installation is prohibited by federal, state and/or local laws, rules, regulations or customs.

WARNING - CALIFORNIA PROPOSITION

65: This product contains chemicals known to the State of California to cause cancer, birth defects or other reproductive harm.

⚠ DANGER



Vapors from flammable liquids will explode and catch fire causing death or severe burns. Do not use or store flammable products such as gasoline solvents or adhesives in the same room or area near the water heater.

- Keep flammable products:
1. Far away from heater,
 2. In approved containers,
 3. Tightly closed and
 4. Out of children's reach.

Installation:
Do not install water heater where flammable products will be stored or used unless the main burner and pilot flames are at least 18" above the floor. This will reduce, but not eliminate, the risk of vapors being ignited by the main burner or pilot flame.

Read and follow water heater warnings and instructions.

Water heater has a main burner and pilot flame.

- The pilot flame:
1. Is on all the time or intermittently (IID).
 2. Will ignite flammable vapors.

- Vapors:
1. Cannot be seen,
 2. Are heavier than air,
 3. Go a long way on the floor,
 4. Can be carried from other rooms to the pilot flame by air currents.

GENERAL SAFETY

To meet commercial hot water needs, this heater is equipped with a manual reset temperature limit that does not exceed 200°F. However, water temperatures over 125°F can cause instant severe burns or death from scalds. This is the preferred temperature setting when supplying general purpose hot water.

Safety and energy conservation are factors to be considered when setting the water temperature on the thermostat. The most energy-efficient operation will result when the temperature setting is the lowest that satisfies the needs consistent with the application.

Maximum water temperatures occur just after burner has shut-off. To determine the water temperature being delivered, turn on the hot water only, place a thermometer in the stream, and read the thermometer.

⚠ DANGER

Water temperature over 125°F can cause instant severe burns or death from scalds.

Children, disabled, and elderly are at highest risk of being scalded.

See instruction manual before setting temperature at water heater.

Feel water before bathing or showering.

Temperature limiting valves are available, see manual.

The following chart details the relationship of water temperature and time with regard to scald injury and may be used as a guide in determining the safest water temperature for your applications.

Temperature	Time to Produce Serious Burn
120°F	More than 5 minutes
125°F	1-1/2 to 2 minutes
130°F	About 30 seconds
135°F	About 10 seconds
140°F	Less than 5 seconds
145°F	Less than 3 seconds
150°F	About 1-1/2 seconds
155°F	About 1 second

Table courtesy of Shriners Burn Institute.

Table A: Time to Produce Serious Burn

Time/Temperature Relationships in Scalds

The temperature of the water in the storage tank heater can be regulated by setting the temperature dial on front of the tankstat. To comply with safety regulations, the tankstat was set at its lowest setting before shipment from the factory.

Fig. 1 illustrates a mechanical tankstat. To adjust the water temperature, insert a small straight screwdriver into slotted screw in hole in front of tankstat and turn wheel to desired setting. Thermostat is adjustable up to 190°F.



Fig. 1: Tankstat Adjustment

DANGER: There is a Hot Water SCALD Potential if the tankstat is set too high.

CAUTION: Hotter water increases the risk of SCALDING!

NOTE: When this heater is supplying general purpose hot water requirements for use by individuals, a thermostatically controlled mixing valve for reducing point of use water temperature is recommended to reduce the risk of scald injury. Contact a licensed plumber or the local plumbing authority for further information.

RECEIVING EQUIPMENT

WARNING: Pump motors should NOT be supported by any type of stand or support from above due to possible misalignment of pump and motor which might occur.

On receipt of the equipment, visually check for external damage to the carton or the shipping crate. If the carton or shipping crate is damaged, make a note on the Bill of Lading and report the damage to the Carrier immediately. Remove the heater from the carton or the shipping crate.

Do NOT use the shipping crate base as an installation base. On occasion, items are shipped loose. Be sure that you receive the number of packages indicated on the Bill of Lading.

When ordering parts, you must specify Model and Serial Number of the heater. When ordering under warranty conditions, you must also specify date of installation.

Raypak recommends that this manual be reviewed thoroughly before installing your Raypak heater. If there are any questions which this manual does not answer, please contact the factory or your local Raypak representative.

Claims for shortages and damages must be filed with carrier by consignee. Permission to return goods must be factory-authorized and are subject to a stocking charge.

Purchased parts are subject to replacement only under the manufacturer's warranty. Debits for defective replacement parts will not be accepted and will be replaced in kind only per our standard warranties.

Model Identification

The model identification number and the heater serial number are found on the heater data plate. The model number will have the form WH1-0514A or similar depending on the heater model. (WH = Hot Water Supply System, 1 = on/off firing, 0514 = size of heater).

Rated inputs are suitable for up to 2000 feet elevation. For elevations above 2000 feet, reduce input 4% for each 1000 feet above sea level.

General Specifications

The Raypak water heaters are design certified and tested under the latest requirements of the American National Standard, ANSI Z21.10.3/CSA 4.3. Each heater has been constructed and pressure tested in accordance with the requirements of Section IV of the American Society of Mechanical Engineers Code, and factory fire tested. Materials are CSA-certified for low-lead content (<.25%).

All Models (Approved)

All models are National Board approved. Temperature and pressure gauge is standard. Intermittent ignition device is standard on models 0514 and up.

Model 0133 has 4-pass heat exchanger, 1 tube per pass.

Models 0181-0401 have 2-pass heat exchangers, 5 tubes first pass, 4 tubes second pass.

Models 0514-1826 have 2-pass heat exchangers, 5 tubes first pass, 4 tubes second pass.

Models 2100-4001 have 2-pass heat exchangers, 9 tubes per pass.

Models 0926-4001 have optional single pass with cast iron headers only.

Hot Water Supply Heaters

All Raypak hot water supply heaters are ASME rated and design certified as hot water heaters, with 125 PSI pressure relief valves.

TYPE WH1 with ON/OFF CONTROLS Models 0133-4001

To be used with storage tank systems. Available with integrally mounted pump, factory mounted and wired for models 0133-1826. Models 0181, 0261, 0331 and 0401 are Low NOx Hot Water Heaters.

TYPE WH2 with MODULATING CONTROLS Models 0133-4001

Hot water supply heater with 110°-170°F gas modulation. Available with integrally mounted pump, factory mounted and wired for models 0133-1826. To be used with storage tank systems.

TYPE WH3 with 2-STAGE CONTROLS Models 0181-4001

Hot water supply heater with low-high fire for 2-stage control. Available with integrally mounted pump, factory mounted and wired for models 0181-1826. To be used with storage tank systems.

INSTALLATION

Installation Codes

Installation must be in accordance with local codes, or, in the absence of local codes, with the latest editions of the National Fuel Gas Code, ANSI Z223.1/NFPA 54, and the National Electrical Code, ANSI/NFPA 70. In Canada installations must conform with the current CAN/CSA B149 and the Canadian Electrical Code Part 1 CSA C22.2 No.1. Where required by the authority having jurisdiction, the installation must conform to American Society of Mechanical Engineers Safety Code for Controls and Safety Devices for Automatically Fired Heaters, CSD-1.

WARNING: This product must be installed by a licensed plumber or gas fitter when installed within the Commonwealth of Massachusetts.

Installation Base

The heater should be mounted on a level, non-combustible surface. Heater must not be installed on carpeting. The heater can be installed on a combustible surface only when the appropriate listed floor shield base is provided. An optional listed floor shield base is available for factory installation with the heater on all indoor models. Do NOT use the shipping base crate as an installation base.

NOTE: The heater should be located in an area where water leakage will not result in damage to the area adjacent to the appliance or to the structure. When such locations cannot be avoided, it is recommended that a suitable drain pan, adequately drained, be installed under the appliance. The pan must not restrict air flow.

WARNING: The heater shall not be located in an area where water sprinklers, or other devices, may cause water to spray through the cabinet louvers and into the heater. This could cause internal rusting or damage electrical components, and void the warranty.

Heater Model Number	Floor Base Part Number
0133	001749
0182/0181	058313
0260/0261	058314
0330/0331	058315
0400/0401	058316
0514	056199
0624	056200
0724	056201
0824	056202
0926*	054597
1083*	054598
1178*	054599
1287*	054600
1414*	054601
1571*	058378
1758*	058379
0962	059233
1125	059234
1223	059235
1336	059236
1468	059237
1631	059238
1826	059239

*Models with factory installed floor shield as standard.

BOLD TYPE indicates Low NOx models.

Table B: Combustible Floorshield Ordering Information

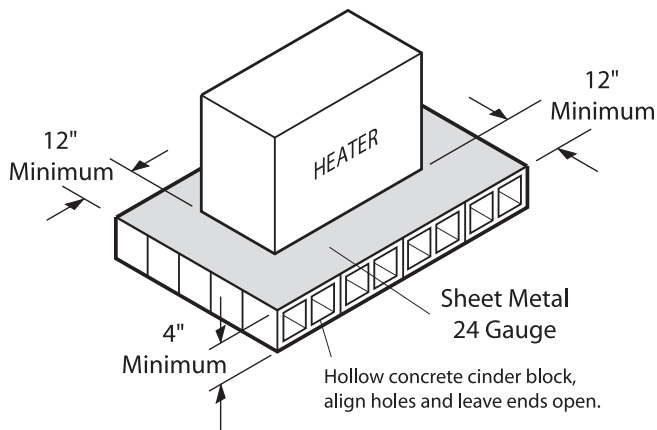

Fig. 2: Alternate Method for Providing a Non-Combustible Base

Clearances

Installation Clearances (All Dimensions are in Inches)

Location	Heater Size				
	0133	0181 to 0401	0514 to 0824	0926 to 1826	2100 to 4001
Floor	See Note 1				
Front	See Note 2				
Back	12	12	12	24	24
Right	6	12	6	24	24
Left	12	12	18	24	24
*Vent	6	6	6	6	6
Indoor Top	42	39	36	24	24
Outdoor Top	Unobstructed				NA

Note 1: Combustible floor shield is required when heater is to be installed on a combustible surface. (See ordering info.)

Note 2: Servicing Clearances: Provide at least 24" (Models 0133-1826), 48" (Models 2100-4001) in front of unit for removal & servicing of the Controls & Burner Tray. Provide at least 18" on side opposite water connections for delimiting of Heat Exchanger Tubes.

*Vent includes factory supplied drafthoods and does not include field supplied vent systems above the drafthood. On Models 2100-4001 drafthood is built into heater.

Table C: Clearances From Combustible Surfaces

Description	Location	Heater Size				
		0133	0181 to 0401	0514 to 0824	0926 to 1826	2100 to 4001
a. 3-1/2 in. thick masonry walls without ventilated air space.	Back	9	9	9	16	16
	Right	5	9	5	16	16
	Left	9	9	12	16	16
	Vent	5	5	5	5	5
	Indoor Top	43	39	36	24	24
	Outdoor Top	Unobstructed				NA
b. 1/2 in. insulation board over 1 in. glass fiber or mineral wool batts.	Back	6	6	6	12	12
	Right	3	6	3	12	12
	Left	6	6	9	12	12
	Vent	3	3	3	3	3
	Indoor Top	30	30	24	16	16
	Outdoor Top	Unobstructed				NA
c. 0.024 sheet metal over 1 in. glass fiber or mineral wool batts reinforced with wire on rear face with ventilated air space.	Back	4	4	4	8	8
	Right	3	4	3	8	8
	Left	4	4	6	8	8
	Vent	3	3	3	3	3
	Indoor Top	24	24	18	12	12
	Outdoor Top	Unobstructed				NA
d. 3-1/2 in. thick masonry wall with ventilated air space.	Back	6	6	6	8	8
	Right	6	6	6	8	8
	Left	6	6	6	8	8
	Vent	6	6	6	6	6
	Indoor Top	42	39	36	24	24
	Outdoor Top	Unobstructed				NA
e. 0.024 sheet metal with ventilated air space.	Back	4	4	4	8	8
	Right	2	4	2	8	8
	Left	4	4	6	8	8
	Vent	2	2	2	2	2
	Indoor Top	24	24	18	12	12
	Outdoor Top	Unobstructed				NA
f. 1/2 in. thick insulation board with ventilated air space.	Back	4	4	4	8	8
	Right	3	4	3	8	8
	Left	4	4	6	8	8
	Vent	3	3	3	3	3
	Indoor Top	24	24	18	12	12
	Outdoor Top	Unobstructed				NA
g. 0.024 sheet metal with ventilated air space over 0.024 sheet metal with ventilated air space.	Back	4	4	4	8	8
	Right	3	4	3	8	8
	Left	4	4	6	8	8
	Vent	3	3	3	3	3
	Indoor Top	24	24	18	12	12
	Outdoor Top	Unobstructed				NA
h. 1 in. glass fiber or mineral wool batts sandwiched between two sheets 0.024 sheet metal with ventilated air space.	Back	4	4	4	8	8
	Right	3	4	3	8	8
	Left	4	4	6	8	8
	Vent	3	3	3	3	3
	Indoor Top	24	24	18	12	12
	Outdoor Top	Unobstructed				NA

Table D: Clearances to Protected Surfaces

NOTE: The heater shall be installed in a space large in comparison to the size of the heater. Large space is defined as having a volume at least sixteen (16) times the total volume of the heater.

Specifications and Dimensions

MODEL 0133

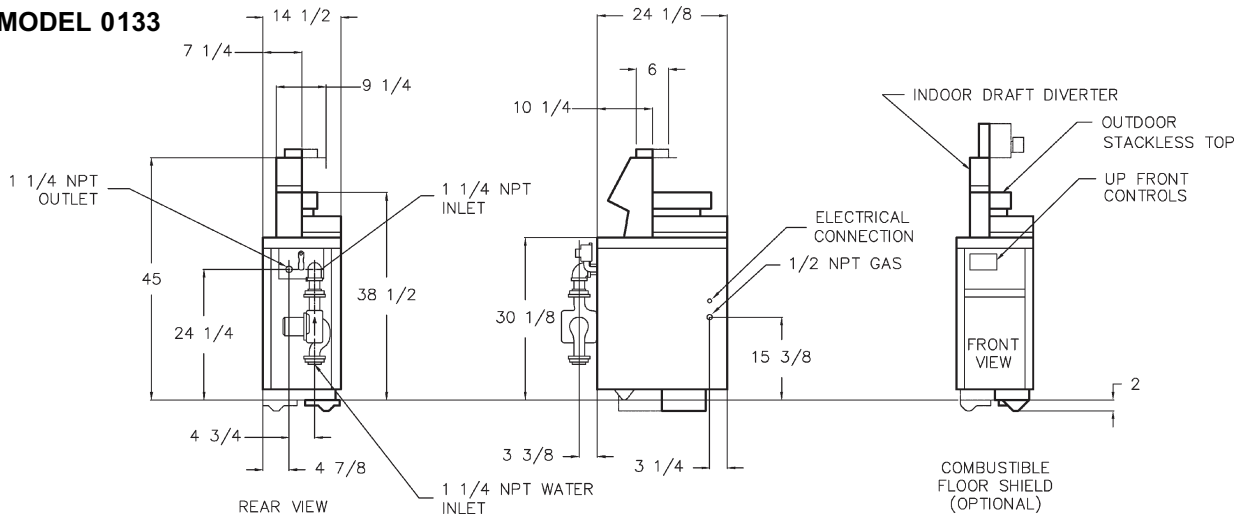

Model Number	Indoor		Outdoor
	Input MBH	Recovery GPH*	Recovery GPH*
WH-0133	136.0	135	132

NOTE:

Ratings are shown for elevations up to 2,000 feet. For elevations over 2,000 feet, reduce ratings 4% for each 1,000 feet above sea level.

* Recovery based on manufacturer's rating.

MODELS 0182-0400 and 0181-0401

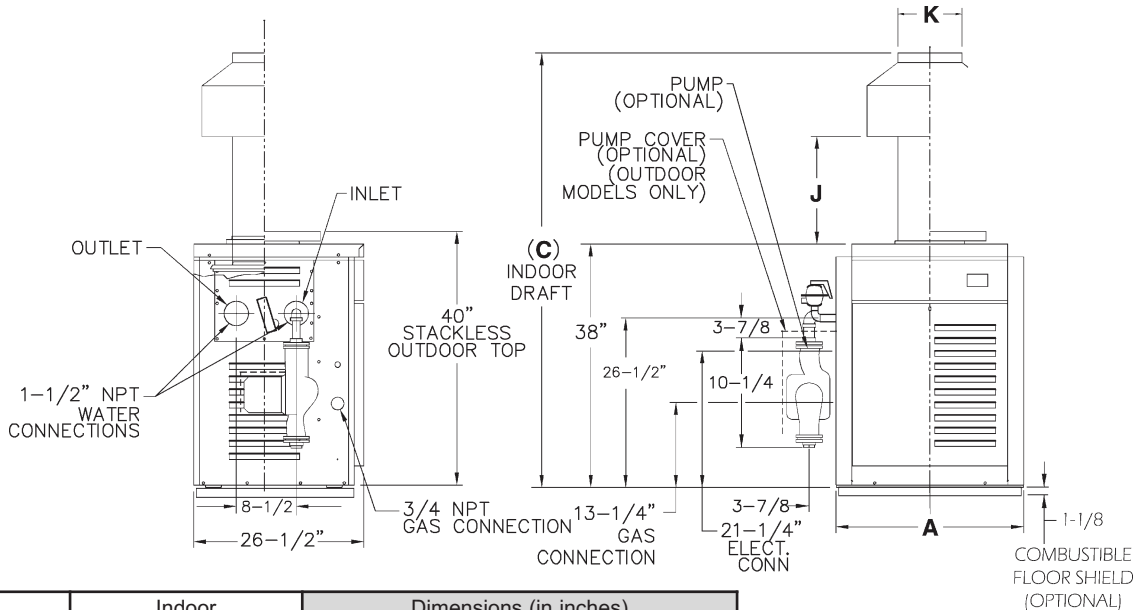

Model Number	Indoor		Dimensions (in inches)			
	Input MBH	Recovery GPH*	Width A	Height C	J	Flue Diameter K
WH-0182/ 0181	181.0	180	18-1/4	62-5/8	12-1/16	6
WH-0206/ 0261	264.0	262	22-3/8	62-7/8	11-1/8	7
WH-0330/ 0331	334.0	332	25-3/4	63-3/4	10-3/4	8
WH-0400/ 0401	399.0	397	29-1/4	65-3/8	12-1/2	9

NOTE:

Ratings are shown for elevations up to 2,000 feet. For elevations over 2,000 feet, reduce ratings 4% for each 1,000 feet above sea level.

Bold type indicates Low NOx models.

* Recovery based on manufacturer's rating.

MODELS 0514-0824

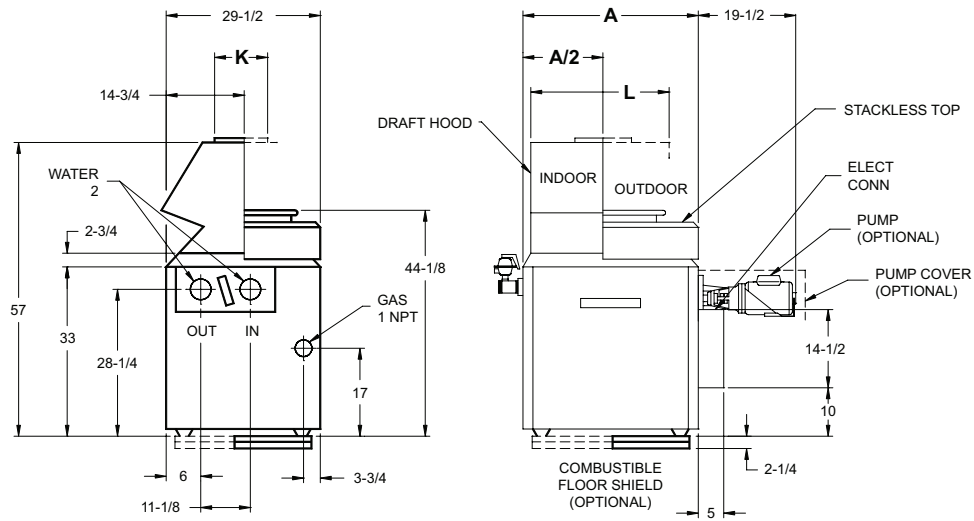

Model Number	Indoor/Outdoor		Dimensions (in inches)		
	Input MBH	Recovery GPH*	Width A	Flue Diameter K	L
WH-0514	511.5	508	32-3/4	10	25-3/8
WH-0624	627.0	623	37-1/2	12	29-1/2
WH-0724	726.0	722	41-5/8	12	34-1/4
WH-0824	825.0	820	45-3/4	14	38-1/2

* Recovery based on manufacturer's rating.

NOTE:

Ratings are shown for elevations up to 2,000 feet. For elevations over 2,000 feet, reduce ratings 4% for each 1,000 feet above sea level.

MODELS 0962-1826

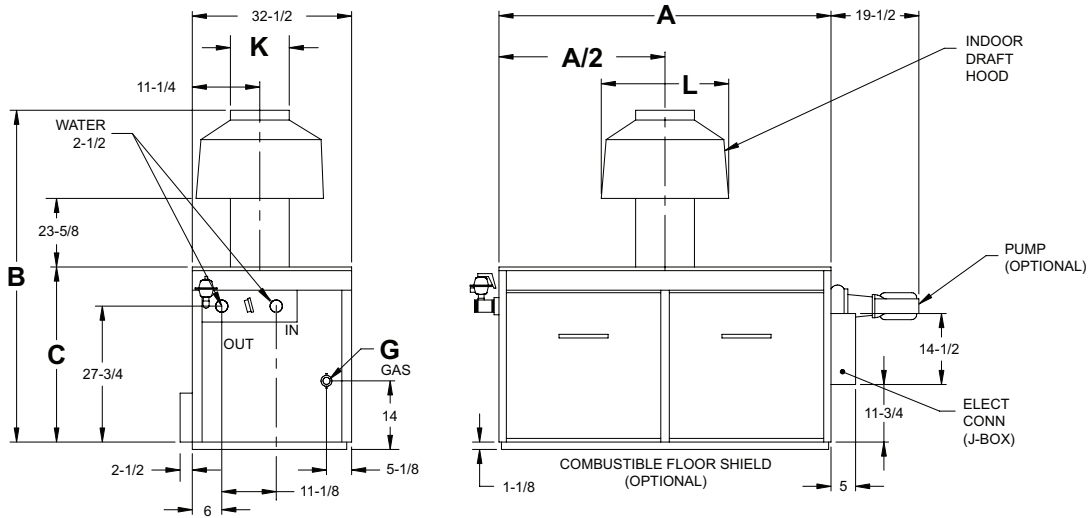

Model Number	Input MBH	Recovery GPH*	Dimensions (in inches)						
			Width A	Overall Height B	Jacket Height C	Gas Conn. G	Flue Diameter K	L	
WH-0962	961.7	956	52-3/8	68-3/4	33-1/2	1	14	28	
WH-1125	1124.7	1118	59-1/4	74-1/2	33-1/2	1	16	32	
WH-1223	1222.5	1215	63-5/8	74-1/2	33-1/2	1-1/4	16	32	
WH-1336	1336.6	1328	68-5/8	76-1/2	33-1/2	1-1/4	18	36	
WH-1468	1467.0	1458	74-7/8	76-1/2	33-1/2	1-1/4	18	36	
WH-1631	1630.0	1620	82-1/8	79-1/2	36-1/2	1-1/4	18	36	
WH-1826	1825.6	1814	89-3/8	81-1/2	36-1/2	1-1/4	20	40	

* Recovery based on manufacturer's rating.

NOTE:

Ratings are shown for elevations up to 2,000 feet. For elevations over 2,000 feet, reduce ratings 4% for each 1,000 feet above sea level.

MODELS 0926-1758

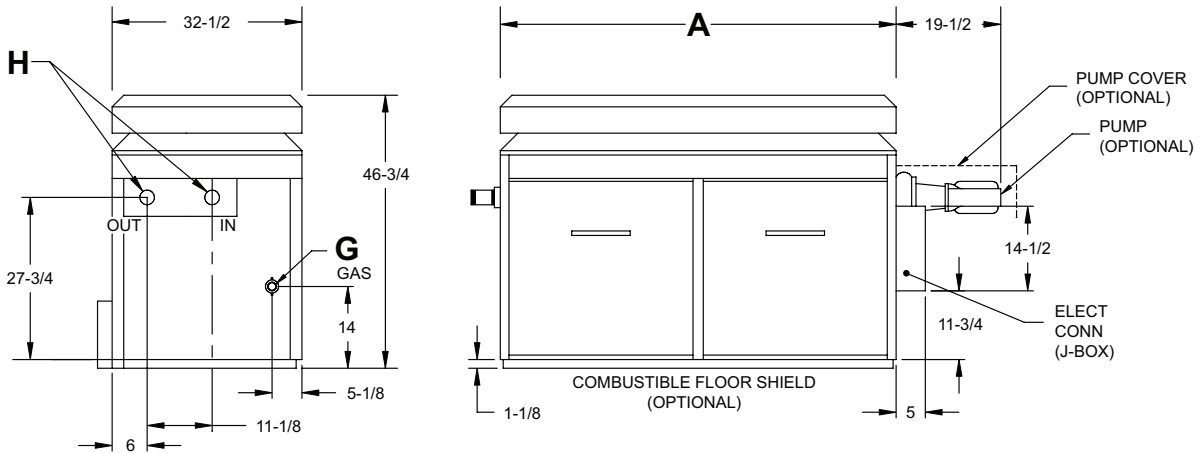

Model Number	Input MBH	Recovery GPH*	Dimensions (in inches)		
			Width A	Gas Conn. G	Water Conns. H
WH-0926	926.0	920	52-3/8	1	2-1/2
WH-1083	1083.0	1076	59-1/4	1	2-1/2
WH-1178	1178.0	1171	63-5/8	1-1/4	2-1/2
WH-1287	1287.0	1279	68-5/8	1-1/4	2-1/2
WH-1414	1413.0	1404	74-7/8	1-1/4	2-1/2
WH-1571	1570.0	1560	82-1/8	1-1/4	2-1/2
WH-1758	1758.0	1747	89-3/8	1-1/4	2-1/2

NOTE:
Ratings are shown for elevations up to 2,000 feet. For elevations over 2,000 feet, reduce ratings 4% for each 1,000 feet above sea level.

* Recovery based on manufacturer's rating.

MODELS 2100-4000

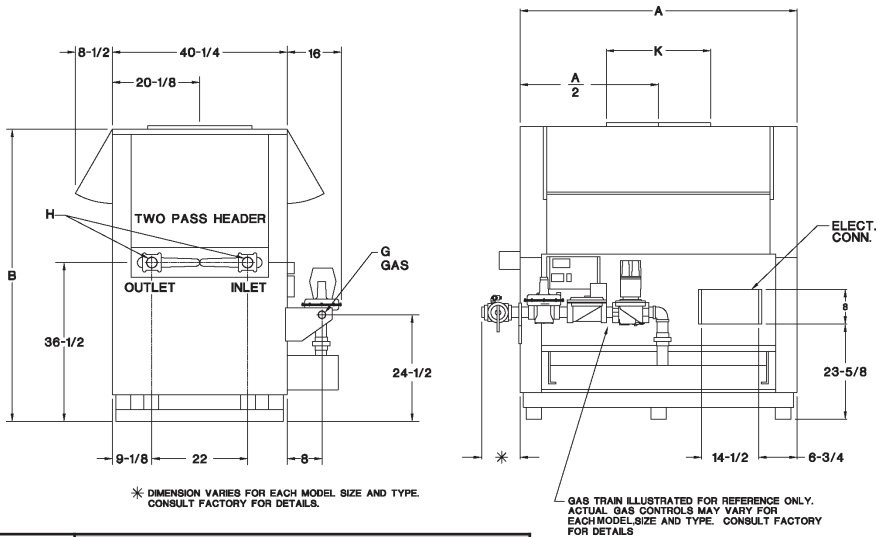

Model Number	Input MBH	Recovery GPH*	Dimensions (in inches)				
			Width A	Overall Height B	Gas Conn. G	Water Conns. H	Flue Diameter K
WH-2100	2100.0	2087	61	68-1/4	**	3	24
WH-2500	2499.0	2484	70	68-1/4	**	3	26
WH-3001	3000.0	2982	81-1/4	68-1/4	2	3	28
WH-3500	3500.0	3479	92-1/2	68-1/4	2	3	30
WH-4001	4000.0	3976	103-3/4	68-1/4	2	3	32

NOTE:
Ratings are shown for elevations up to 2,000 feet. For elevations over 2,000 feet, reduce ratings 4% for each 1,000 feet above sea level.

* Recovery based on manufacturer's rating.

** 1-1/2" or 2" contingent on code requirements

Outdoor Water Heaters

These heaters are design certified for outdoor installation. Heaters must not be installed under an overhang of less than three (3) feet from the top on the heater. Three (3) sides must be open in the area under the overhang. Roof water drainage must be diverted away from the heaters installed under overhangs with the use of gutters.

The point from where the flue products exit the heater must be a minimum of four (4) feet below, four (4) feet horizontally from or one (1) foot above any door, window or gravity inlet to a building. The top surface of the heater shall be at least three (3) feet above any forced air inlet, or intake ducts located within ten (10) feet horizontally.

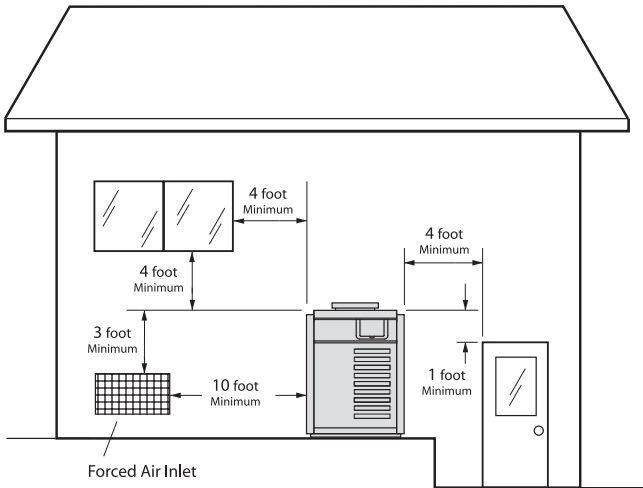

Fig. 3: Outdoor Clearances from Openings

High Wind Conditions (Outdoor Units Only)

In areas where high winds are frequent, it may be necessary to locate the heater a minimum of 3' from high vertical walls, or install a wind break so the heater is not in direct wind current.

Combustion Air (Indoor Units Only) Air for Combustion and Ventilation

The heater must have both combustion and ventilation air. Minimum requirements for net free air supply openings are 12 inches from ceiling for ventilation and 12 inches from the floor for combustion air as outlined in ANSI Z223.1, and any local codes that may have jurisdiction.

CAUTION: Combustion air must not be contaminated by corrosive chemical fumes which can damage the heater. Measures must be taken to prevent the entry of corrosive chemical fumes to the combustion and ventilation air supply. Such chemicals include, but are not limited to, chlorinated and/or fluorinated hydrocarbons such as found in refrigerants, aerosol propellants, dry-cleaning fluids, degreasers, and paint removers. Other harmful elements may come from bleaches, air fresheners, or mastics. Vapors from these types of products can form corrosive acid compounds when burned in a gas flame. The resulting acidic condensate can damage or substantially reduce the life of the heater. It may become necessary to provide outside air directly to the heater in order to avoid this problem.

a. All Air From Inside The Building:
Each opening shall have a minimum net free square inches as noted:

Model	Square Inches	Model	Square Inches
0133	136	1223	1223
0182/0181	181	1336	1337
0260/0261	264	1468	1467
0330/0331	334	1631	1630
0400/0401	399	1826	1826
0514	512	2100	2100
0624	627	2500	2499
0724	726	3001	3000
0824	825	3500	3500
0962	962	4001	4000
1125	1125		

BOLD TYPE indicates Low NOx models.

Table E: All Air From Inside The Building

b. All Air From Outdoors:
When air is supplied directly from outside of building, each opening shall have a minimum net free square inches as noted:

Model	Square Inches	Model	Square Inches
0133	34	1223	306
0182/0181	46	1336	335
0260/0261	66	1468	367
0330/0331	84	1631	408
0400/0401	100	1826	457
0514	128	2100	525
0624	157	2500	625
0724	182	3001	750
0824	207	3500	875
0962	241	4001	1000
1125	282		

BOLD TYPE indicates Low NOx models.

Table F: All Air From Outdoors

NOTE: If louvers, grills or screens are used on the openings, obtain the net free area from their supplier or manufacturer. If the design free area of a louver is not known nor available, it shall be assumed that **wood** louvers will have **20-25** percent free area and **metal** louvers will have **60-75** percent free area as specified in the National Fuel Gas Code.

Venting

WARNING: Examine the venting system at least once a year. Check all joints and vent pipe connections for tightness, corrosion or deterioration.

Outdoor Installations

Model 0133

1. Remove the front (4) screws.
2. Line up outdoor top vent opening over heater vent opening.
3. Lower outdoor top onto unit lining up slots in the outdoor top with screws holes in jacket top.
4. Reinstall (5) screws to secure jacket top and outdoor top to unit.

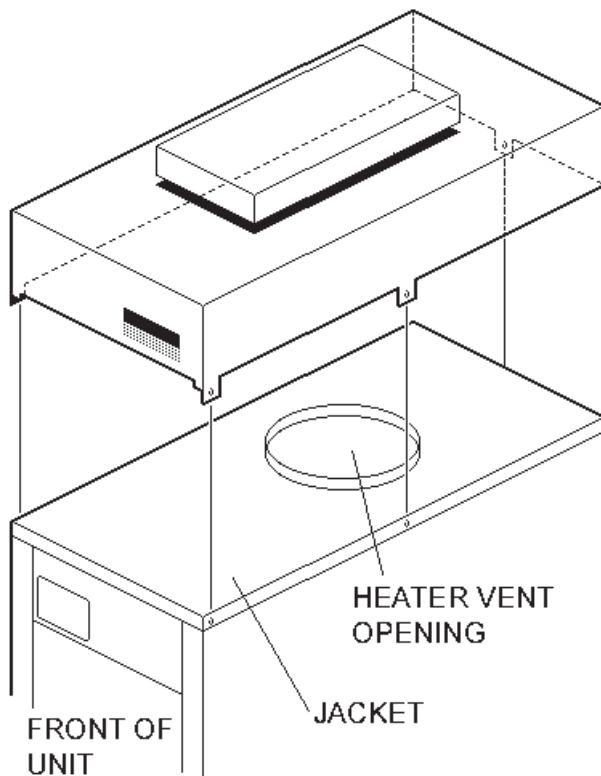

Fig. 4: Outdoor Top Installation

Models 0181-0401 and 0182-0400

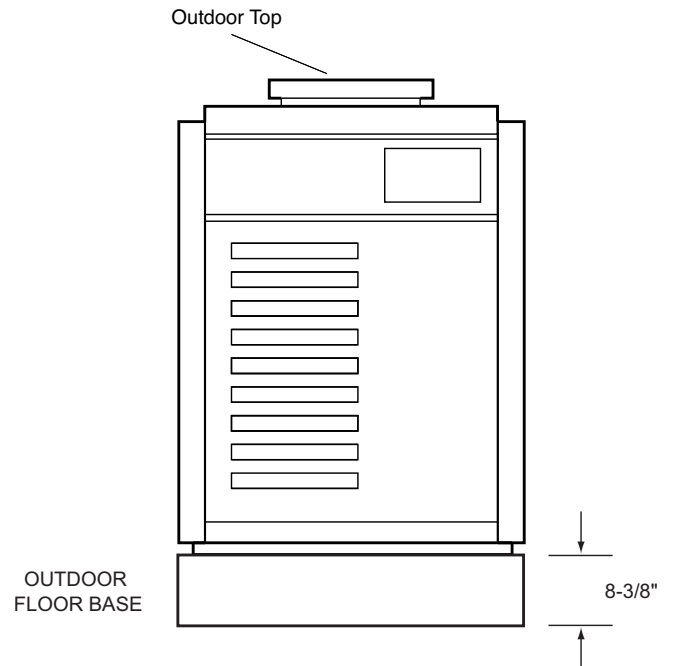
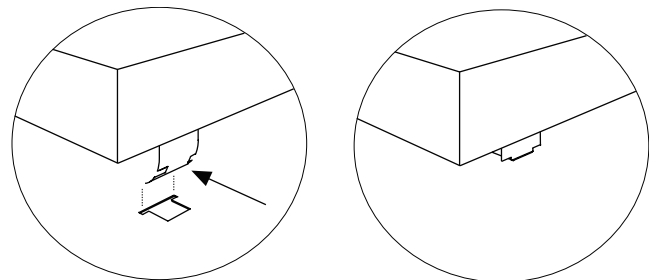

Fig. 5: Outdoor Top Installation

Vent Terminal (Outdoor) Stackless Top Installation

1. Insert tabs into keyhole (4 places).
2. Snap tabs into keyholes so as not to pull out.



Pagoda Top (Shipped Loose with Heater)

Fig. 6: Outdoor Top Installation

Models 0514-0824

1. Lower outdoor "Stackless" top onto unit. Position top so it is centered on unit from side-to-side and front-to-rear.

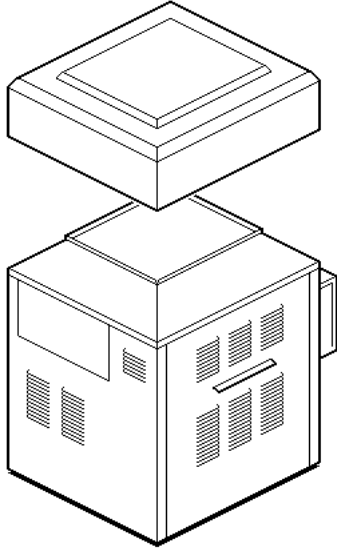

Fig. 7: Outdoor Top Installation

2. Tighten the (4) screws (Shown below) until they come in contact with the unit jacket top, then evenly tighten all (4) screws to secure to unit.

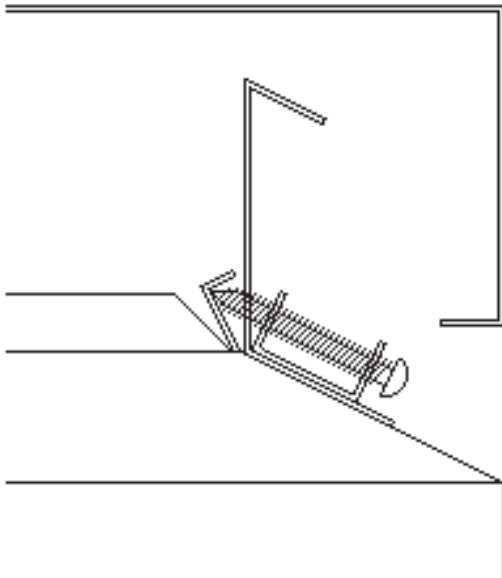

Fig. 8: Outdoor Top Installation

Models 0926-1758

Heaters are shipped with outdoor vent terminal factory installed.

Models 2100-4001

These units are not certified for outdoor installation.

Indoor Installations

WARNING: Do not use the "one permanent opening" method if the equipment room is under negative pressure conditions or the equipment is common vented with other gas-fired appliances.

WARNING: These heaters must not be connected into any portion of mechanical draft systems operating under positive pressure. To do so may cause the flue products to be discharged into the living space causing serious health injury.

Model 0133

Refer to Fig. 9 on the following page.

1. Shut-off main electrical power switch to heater.
2. Turn heater manual ON/OFF switch, located in upper control panel, to the "OFF" position.
3. Shut-off gas supply and water supply to the heater.
4. Mount draffhood on heater and attach with the 8 sheet metal screws provided. Draffhood should be positioned with the vent sensor located on the front left side as shown.
5. Remove plastic plug from left side of heater jacket and install the plastic grommet provided.
6. Route flue sensor wire harness through the grommet installed in Step 5.
7. Remove door and locate wire from roll out sensor to High Limit with the male/female connector.
8. Disconnect male/female connector and attach to the 2 wires from draffhood vent sensor harness.

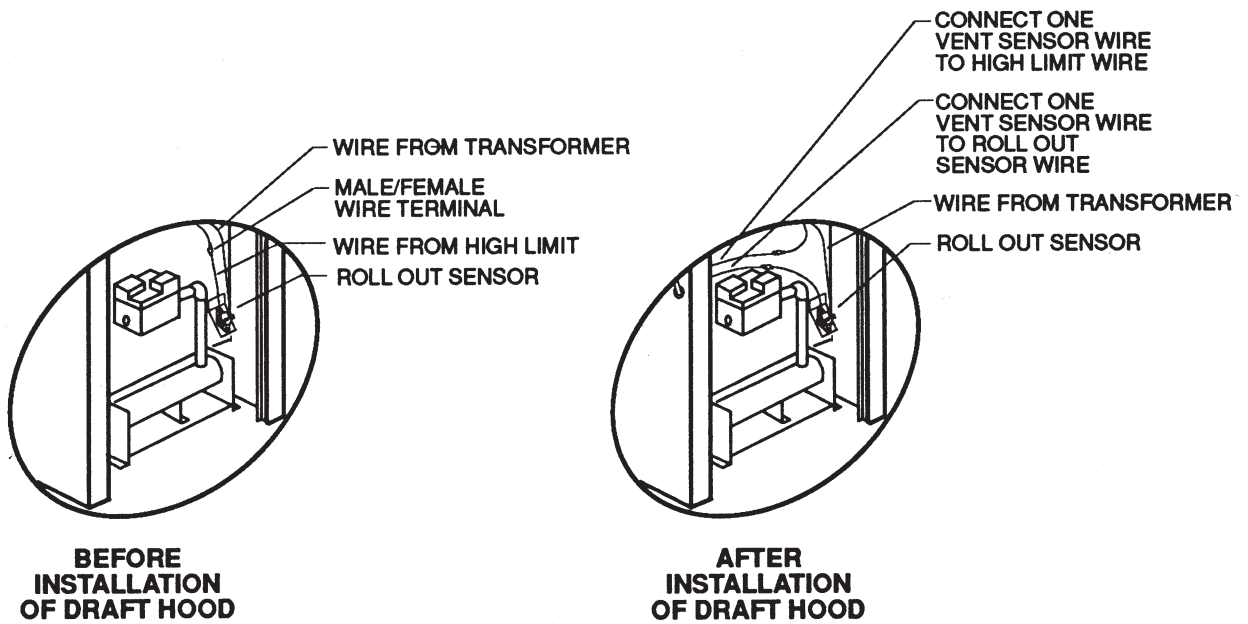
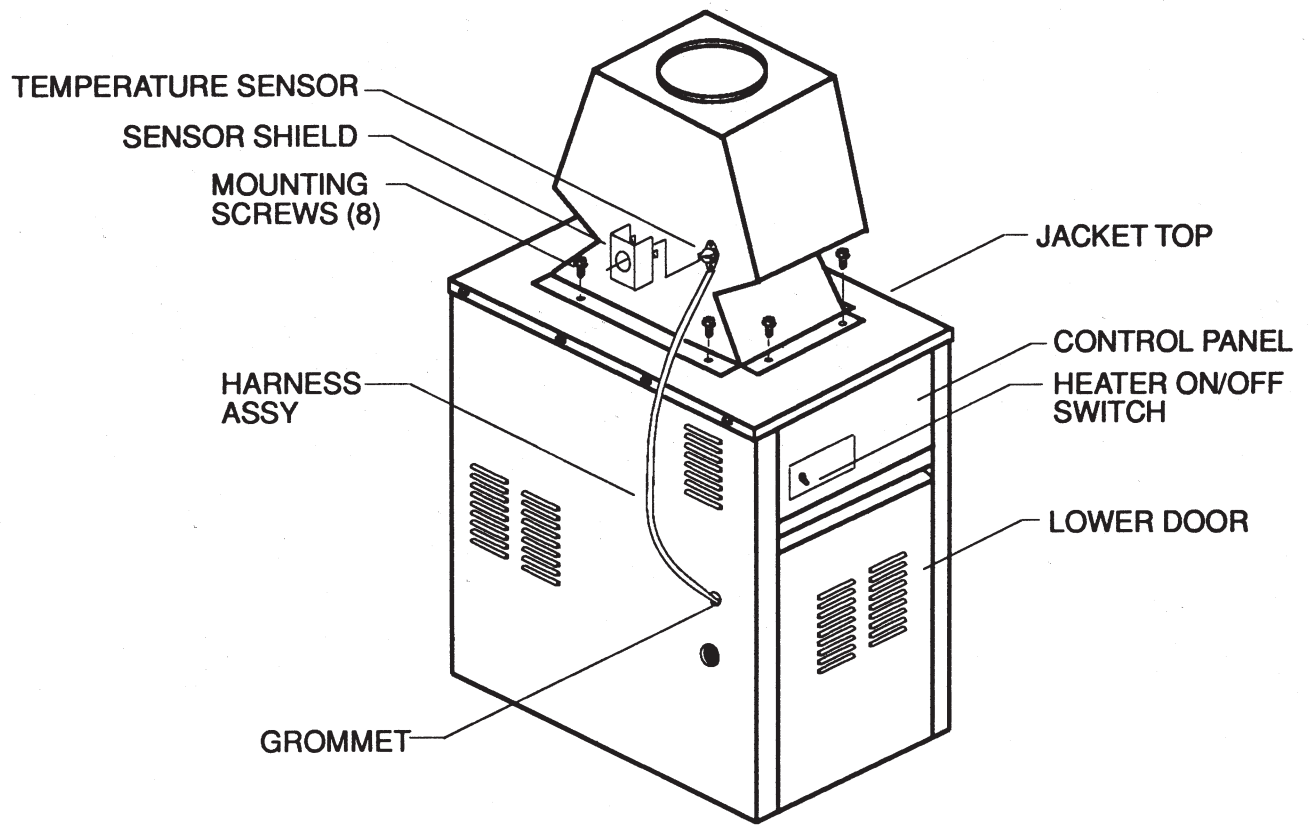

Fig. 9: Indoor Top Installation

Models 0181-0401 and 0182-0400

Vent Terminal/Indoor Stack Installation

1. Remove the louvered jacket top by removing four (4) #10 flathead screws.
2. If originally installed, remove "Pagoda" top from the louvered jacket top.
3. Place the inner stack adapter panel over the flue collector inside the heater. Make sure the flanged side of the flue opening is up.
4. Turn the stack (drafthood) upside down and set it down bottom side up.
5. Turn the jacket top panel (removed in step 1) upside down and place it over the stack.
6. Attach the three (3) mounting brackets to the stack using the screws provided and the holes that are pre-drilled in the stack. Make sure the brackets are positioned with the flange near the top side of the stack (see Fig. 10). Caution must be taken not to over tighten and strip the screw threads.
7. Turn the assembled stack and jacket top, right side up. The jacket top will be trapped between the brackets and the top of the stack. Place the stack over the inner adapter panel flanged hole and lower the louvered jacket top panel back into its original position. Reinstall the four (4) green #10 flathead screws removed in step 1 above.

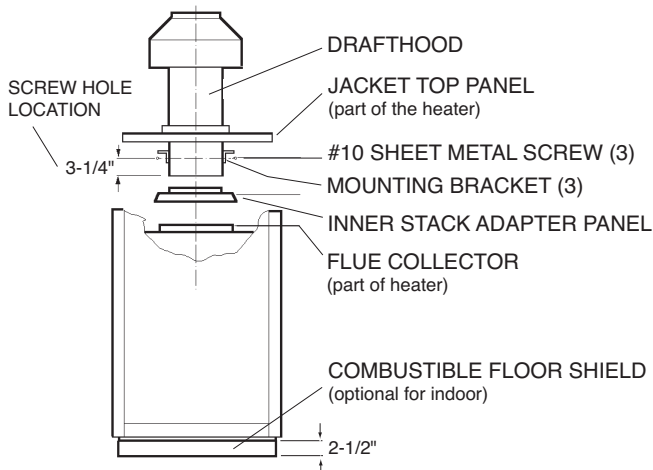

Fig. 10: Indoor Top Installation

Models 0514-0824

Locate and assemble as shown below. Secure with screws supplied in envelope in carton.

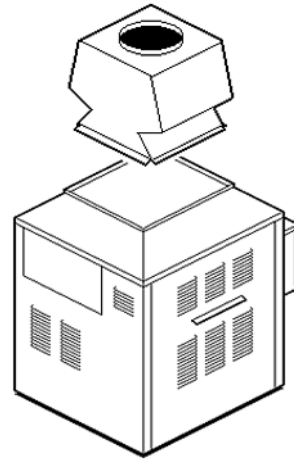

Fig. 11: Indoor Top Installation

Models 0962-1826

Locate and assemble as shown below. Secure with screws supplied in envelope in carton.

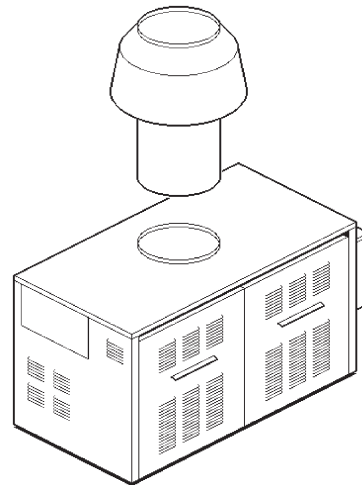

Fig. 12: Indoor Top Installation

Models 2100-4001

These models have built-in drafthoods. For proper operation, the drafthood outlet must be connected to the venting system.

Vent Piping

Vent piping of the same size as the draft hood outlet is recommended, however, when the total vent height is at least ten (10) feet (draft hood relief opening to vent terminal), the vent pipe size may be reduced as specified in the National Fuel Gas Code, ANSI Z223.1.

Avoid long horizontal runs of vent pipe and too many elbows. If installation requires horizontal non-vertical runs, the vent pipe must have a minimum of 1/4 inch per foot rise and should be supported at not more than five foot intervals. Plumber's tape, crisscrossed, will serve to space both horizontal and vertical piping. Gas vents supported only by the flashing and extending above the roof more than five feet should be securely guyed or braced to withstand snow and wind loads. We recommend use of an insulated vent pipe spacer through the roofs and walls.

For protection against rain or blockage by snow, the vent pipe must terminate with a vent cap which complies with the local codes or, in the absence of such codes, to the latest edition of the National Fuel Gas Code, ANSI Z223.1.

The discharge opening must be a minimum of two feet vertically from the roof surface and at least 2 feet higher than any part of the building or equipment within ten feet. The vent stack shall be at least 5 feet in vertical height above the draft hood outlet. The vent cap location shall have a minimum clearance of 4 feet horizontally from, and in no case above or below, unless a 4-foot horizontal distance is maintained, from electric meters, gas meters regulators and relief equipment.

The weight of the vent stack or chimney must not rest on heater draft hood. Support must be provided in compliance with applicable codes. The heater top and draft hood must be readily removable for maintenance and inspection. Vent pipe should be adequately supported to maintain proper clearances from combustible construction Type "B" double wall or equivalent vent pipe is recommended. However single wall metal vent pipe may be used as specified in the latest edition of the National Flue Gas Code ANSI Z223.1.

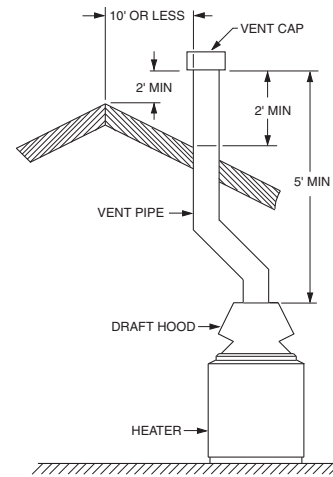

Fig. 13: Vent Piping

Manifolds that connect more than one heater to a common chimney must be sized to handle the combined load. Consult available guides for proper sizing of the manifold and the chimney. At no time should the area be less than the area of the largest outlet.

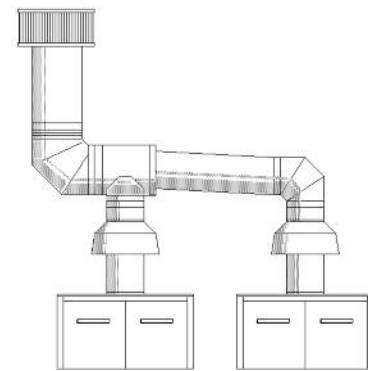

Fig. 14: Common Vent Piping

At the time of removal of an existing heater, the following steps shall be followed with each appliance remaining connected to the common venting system placed in operation, while the other appliances remaining connected to the common venting system are not in operation.

- (a) Seal any unused openings in the common venting system.
- (b) Visually inspect the venting system for proper size and horizontal pitch and make sure there is no blockage or restriction, leakage, corrosion or other deficiency which could cause an unsafe condition.
- (c) Insofar as is practical, close all building doors and windows and all doors between the space in which the appliances remaining connected to the common venting system are located and other spaces of the building. Turn on clothes dryers and any

appliance not connected to the common venting system. Turn on any exhaust fans, such as range hoods and bathroom exhausts, so they will operate at maximum speed. Do not operate a summer exhaust fan. Close fireplace dampers.

- (d) Place in operation the appliance being inspected. Follow the lighting instructions. Adjust thermostat so appliance will operate continuously.
- (e) Test for spillage at the draft hood relief opening after 5 minutes of main burner operation. Use the flame of a match or candle, or smoke from a cigarette, cigar or pipe.
- (f) After it has been determined that each appliance remaining connected to the common venting system is venting properly, return doors, windows, exhaust fans, fireplace dampers and any other gas burning appliance to their previous conditions of use.
- (g) Any improper operation of the common venting system should be corrected so that the installation conforms with the latest edition of the National Fuel Gas Code, ANSI Z223.1. When re-sizing any portion of the common venting system, the common venting system should be re-sized to approach the minimum size as determined using the appropriate tables in the National Fuel Gas Code, ANSI Z223.1.

For special venting applications that require reduced vent sizes and through-the-wall venting, the Type D Induced Draft Assembly can be used. Consult the factory or your local Raypak representative.

Vent Damper Installation

Models 0133 Through 0180 (Where Required)

Location

The vent damper must be located in the vent so that it serves only the appliance for which it is intended.

If improperly installed, a hazardous condition, such as an explosion or carbon monoxide poisoning, could result. Make certain that it is mounted in an accessible location at least 6 in. from any combustible material or the heat exchanger and that the position indicator is in a visible location.

The vent damper must be installed after the appliance draft hood, as close to the draft hood as practicable, and without modification of the draft hood.

WARNING: Do not use thermally actuated vent dampers on modulating heater. To do so, may result in asphyxiation. Use only a mechanically actuated vent damper device that is electrically interlocked with the modulating heater operation.

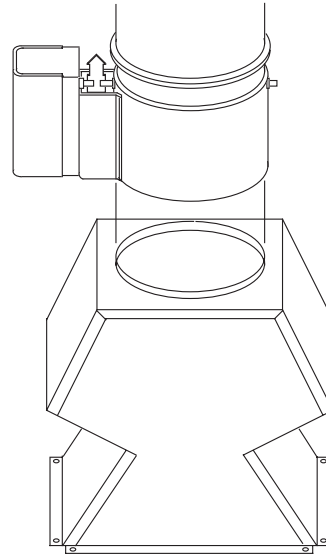

Fig. 15: Vent Damper

Mounting

On vertical vents, the vent damper may be mounted with the actuator in any position. On horizontal vents, do not mount the actuator either directly above or directly below the vent pipe; mount the vent damper actuator to the side of the vent, as shown in Fig. 16.

The vent damper is set up for a continuous pilot system. If the vent damper is installed on an Intermittent Pilot or Direct Spark Ignition equipped system, the energy savings of the vent damper can be improved by plugging the hole in the vent damper blade using the knockout plug, Part No. 105612R, provided in the parts envelope.

DO NOT plug the hole if installing the vent damper on a continuous pilot system as this will create a hazardous condition.

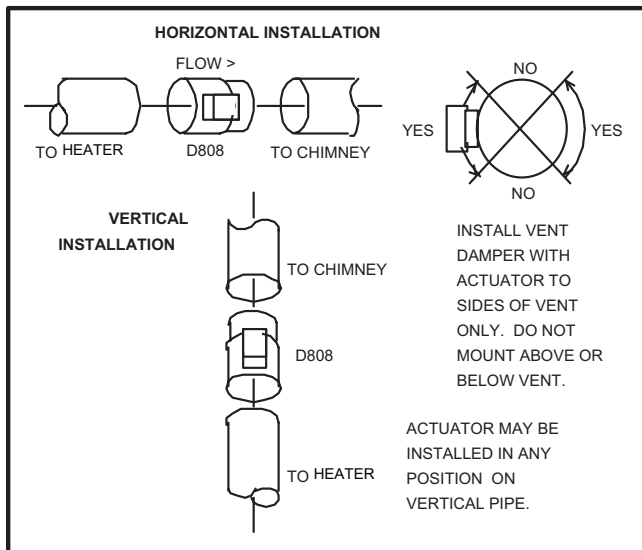

Fig. 16: Installing Vent Damper

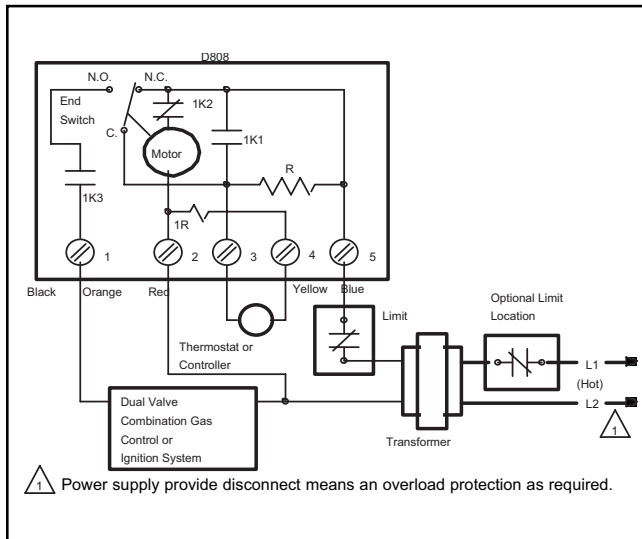

Fig. 17: Vent Damper General Wiring Diagram

INSTALL THE VENT DAMPER TO SERVICE ONLY THE SINGLE APPLIANCE FOR WHICH IT IS INTENDED. IF IMPROPERLY INSTALLED, A HAZARDOUS CONDITION, SUCH AS AN EXPLOSION OR CARBON MONOXIDE POISONING, COULD RESULT.

Vent Damper

For safe, efficient operation, the vent damper and all flue product carrying areas of the appliance must be checked annually, with particular attention given to deterioration from corrosion or other sources. Check vent damper operation as follows:

1. When the heater is off, check that the vent damper position indicator points to the closed position, Fig. 18.

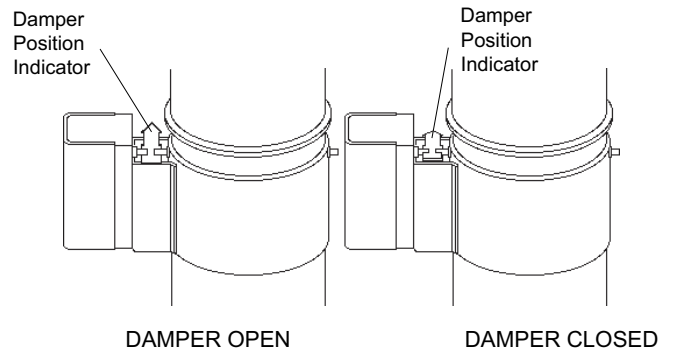

Fig. 18: Vent Damper position Indicator Showing Open & Closed Positions

2. Turn the thermostat or controller up to call for heat and check that the vent damper indicator points to the open position, Fig. 18.
3. Turn the thermostat or controller down again and check that the vent damper position indicator returns to the closed position.

THE VENT DAMPER MUST BE INSPECTED AT LEAST ONCE A YEAR BY A TRAINED, EXPERIENCED SERVICE TECHNICIAN. THE NAME OF THE PERSON WHO ORIGINALLY INSTALLED YOUR VENT DAMPER IS SHOWN ON THE INSTALLATION LABEL. DAMPER MUST BE IN THE OPEN POSITION WHEN HEATER MAIN BURNERS ARE OPERATING.

WARNING: Do not use thermally actuated vent dampers on a modulating heater. To do so may result in asphyxiation. Use only a mechanically actuated vent damper device that is electrically interlocked with the modulating heater operation.

Plumbing

General

Heater should be located so that any water leaks will not cause damage to any adjacent areas or structures.

Gas Supply Connections

Gas piping must have a sediment trap ahead of the heater gas controls, and a manual shut-off valve located outside the heater jacket. All gas piping should be tested after installation in accordance with local codes.

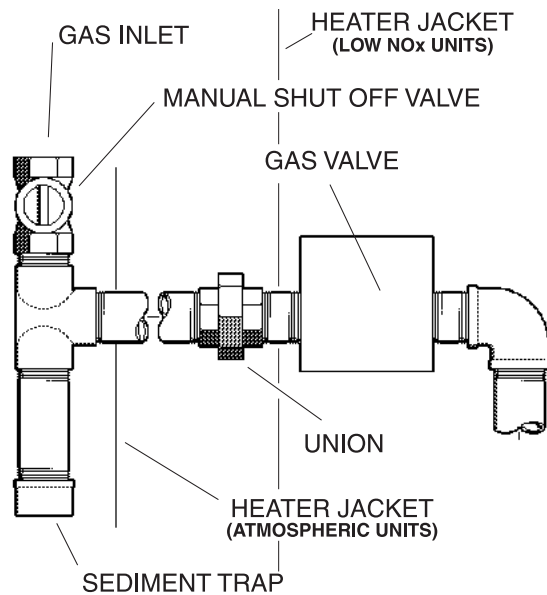

Fig. 19: Sediment Trap

CAUTION: The heater and its manual shut-off valve must be disconnected from the gas supply during any pressure testing of that system at test pressures in excess of 1/2 PSIG. Dissipate test pressure in the gas supply line before reconnecting the heater and its manual shut-off valve to gas supply line. FAILURE TO FOLLOW THIS PROCEDURE MAY DAMAGE THE GAS VALVE. OVER PRESSURED GAS VALVES ARE NOT COVERED BY WARRANTY. The heater and its gas connections shall be leak tested before placing the appliance in operation. Use soapy water for leak test do NOT use open flame.

NOTE: Do not use teflon tape on gas line pipe thread. A flexible sealant approved for the fuel being used is recommended.

CAUTION: For proper operation, no more than a 30% drop in gas supply pressure from no-load to full-load conditions is acceptable. Under no circumstances should the pressure be outside the listed operational range.

MAXIMUM EQUIVALENT PIPE LENGTH																		
NATURAL GAS 1000 BTU/Cubic Foot										.60 SPECIFIC GRAVITY @ 0.5" W.C. PRESSURE DROP								
PROPANE GAS 2500 BTU/Cubic Foot										1.53 SPECIFIC GRAVITY @ 0.6" W.C. PRESSURE DROP								
1/2"		3/4"		1"		1-1/4"		1-1/2"		2"		2-1/2"		3"		4"		
N	P	N	P	N	P	N	P	N	P	N	P	N	P	N	P	N	P	
0133	15	35	60	145	200	500												
*0182/0181	-	15	30	65	95	250	400	-	-	-	-	-	-	-	-	-	-	
*0260/0261	-	10	20	40	60	140	250	560										
*0330/0331		-	15	25	35	85	150	380	360	-	-	-	-	-	-	-	-	
*0400/0401		-	-	15	25	60	100	260	250	-	-	-	-	-	-	-	-	
0514			-	10	15	35	65	150	130	360	500	-	-	-	-	-	-	
0624			-	-	10	25	45	100	95	250	340	-	-	-	-	-	-	
0724			-	-	-	20	35	80	75	180	260	600	-	-	-	-	-	
0824			-	-	-	15	25	60	55	130	185	480	500	-	-	-	-	
0926/0962			-	-	-	15	20	45	45	110	150	360	400	-	-	-	-	
1083/1125			-	-	-	10	15	35	35	80	120	300	300	-	-	-	-	
1178/1223			-	-	-	-	-	25	25	60	85	220	200	-	-	-	-	
1287/1336			-	-	-	-	-	25	20	55	75	180	170	325	560	-	-	
1414/1468			-	-	-	-	-	20	15	45	65	150	165	300	500	-	-	
1571/1631			-	-	-	-	-	15	15	35	50	120	125	250	400	-	-	
1758/1826			-	-	-	-	-	15	10	30	40	100	100	225	340	-	-	
2100			-	-	-	-	-	10	10	25	30	80	75	175	260	-	-	
2500			-	-	-	-	-	-	-	15	20	55	55	135	160	400	600	
3001			-	-	-	-	-	-	-	10	15	35	40	85	120	250	500	
3500			-	-	-	-	-	-	-	-	10	30	30	45	80	200	400	
4001			-	-	-	-	-	-	-	-	5	20	25	35	65	160	300	

* Models 0181, 0261, 0331, and 0401 are Low NOx units and are not available in propane.

A minimum of 7" WC and a maximum of 10.5" WC upstream pressure under load, and no load conditions must be provided for natural gas or a minimum of 11" WC and a maximum of 13" for propane.

Pressure drops from the no load condition to the full load condition must be no more than 30% for proper operation.

Table G: Maximum Equivalent Pipe Lengths

Gas Pressure Regulator

The gas pressure regulator located in the gas valve is preset nominally at 4" WC for natural gas, and 11" WC for propane. Between the gas valve and the burners is a 1/8" pipe plug. The pressure at this point, taken with a manometer, should be about 3.7" WC natural gas and 10.5" WC propane. Models 0181, 0261, 0331, and 0401 should be 3.9 WC natural gas. If an adjustment is needed, turn adjustment screw clockwise to increase pressure, or counter-clockwise to decrease pressure.

Venting of Diaphragm Gas Components

Gas train components that have diaphragms in their construction are supplied with a bleed line connection that must be connected to the outside atmosphere as required by the National Fuel Gas Code. Under NO circumstances shall bleed lines terminate in the gas utilization equipment flue or exhaust system. Care should be used to prevent obstruction to the bleed lines, as blocked lines could prevent gas valves or other devices from operating.

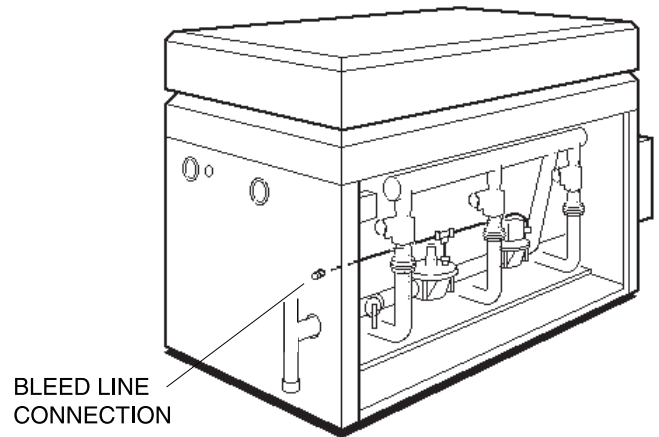

Fig. 20: Bleed Line Connection

Flow Rates

MAXIMUM AND MINIMUM FLOW RATES															
MODEL SIZE	2-PASS HEAT EXCHANGER							1-PASS HEAT EXCHANGER							
	MAX			MIN			HDR CONN	MAX			MIN			HDR CONN	
	GPM	ΔT	ΔP FT	GPM	ΔT	ΔP FT		GPM	ΔT	ΔP FT	GPM	ΔT	ΔP FT		
0133*	22	10	14.7	10	22	3.3	1-1/4"								
0182/0181	45	7	9.2	20	15	1.8	1-1/2"								
0260/0261	45	10	9.4	20	22	1.9	1-1/2"								
0330/0331	45	12	9.6	20	28	1.9	1-1/2"								
0400/0401	45	15	9.8	20	33	2.0	1-1/2"								
0514	90	9	9	40	21	1.8	2"								
0624	90	12	9.5	40	26	1.9	2"								
0724	90	13	10	40	30	2.0	2"								
0824	90	15	10.5	40	34	2.1	2"								
0926	90	17	11	40	38	2.2	2 1/2"	200	8	9.7	90	17	2.1	3"	
0962	90	18	11	40	39	2.2	2 1/2"	200	8	9.7	90	18	2.1	3"	
1083	90	20	12	44	40	2.9	2 1/2"	200	9	10.3	90	20	2.3	3"	
1125	90	20	12	46	40	3.1	2 1/2"	200	9	10.3	90	20	2.3	3"	
1178	90	21	12.5	48	40	3.6	2 1/2"	200	10	11	90	21	2.4	3"	
1223	90	22	12.5	50	40	3.9	2 1/2"	200	10	11	90	22	2.4	3"	
1287	90	23	13.2	53	40	4.5	2 1/2"	200	11	11.7	90	23	2.5	3"	
1336	90	24	13.2	55	40	4.9	2 1/2"	200	11	11.7	90	24	2.5	3"	
1414	90	26	14	58	40	5.8	2 1/2"	200	12	12.2	90	26	2.7	3"	
1468	90	27	14	60	40	6.2	2 1/2"	200	12	12.2	90	27	2.7	3"	
1571	90	29	14.5	64	40	7.3	2 1/2"	200	13	13	90	29	2.8	3"	
1631	90	30	14.5	67	40	8.1	2 1/2"	200	13	13	90	30	2.8	3"	
1758	90	32	15.4	72	40	9.7	2 1/2"	200	14	14.7	90	32	3	3"	
1826	90	33	15.4	75	40	10.6	2 1/2"	200	15	14.7	90	33	3	3"	
2100	200	17	14.8	90	38	3.2	3"	400	9	18	180	19	4	4"	
2500	200	20	15.8	102	40	4.3	3"	400	10	18.8	180	23	4.1	4"	
3001	200	25	16.7	123	40	6.5	3"	400	12	19.5	180	27	4.3	4"	
3500	200	29	17.5	144	40	9.3	3"	400	14	20.5	180	32	4.5	4"	
4001	200	33	18.7	164	40	12.8	3"	400	16	21.5	180	36	4.7	4"	

GPM Flow rates limited by maximum acceptable velocity through heat exchanger tubes. May be increased by 10% for closed heating systems.

* 4 Pass Heat Exchanger

BOLD TYPE indicates Low NOx models.

Table H: Maximum and Minimum Flow Rates

MODELS		WATER HARDNESS														
		SOFT					MEDIUM					HARD				
		0-4 Grains Per Gallon					5-15 Grains Per Gallon					16-25 Grains Per Gallon*				
Indoor	Outdoor	ΔT	GPM	ΔP	MPS	SHL	ΔT	GPM	ΔP	MPS	SHL	ΔT	GPM	ΔP	MPS	SHL
0133	0133	22	10	3.4	1-1/4	5.1	17	13	5.5	1-1/4	8.2	10	22	14.7	1-1/4	22.0
0182/0181	0182	15	20	1.8	1-1/2	4.6	12	26	3.1	1-1/2	7.5	7	45	9.2	1-1/2	20.8
0260/0261	0260	21	20	1.9	1-1/2	4.6	17	26	3.1	1-1/2	7.6	10	45	9.4	1-1/2	21.0
0330/0331	0330	27	20	1.9	1-1/2	4.7	21	26	3.2	1-1/2	7.7	12	45	9.6	1-1/2	21.2
0400/0401	0400	30	22	2.3	1-1/2	5.6	25	26	3.3	1-1/2	7.8	15	45	9.8	1-1/2	21.3
0514	0514	20	42	2.0	2	4.8	16	52	3.0	2	7.1	9	90	9.0	2	19.1
0624	0624	25	41	2.0	2	4.7	19	54	3.4	2	7.9	11	90	9.5	2	20.9
0724	0724	29	41	2.1	2	4.9	20	60	4.4	2	9.8	13	90	10.0	2	21.4
0824	0824	30	45	2.6	2	5.9	20	68	6.0	2	12.8	15	90	10.5	2	21.9
0962	0926	30	53	3.8	2-1/2	5.3	20	79	8.5	2-1/2	11.5	18	90	11.0	2-1/2	15.2
1125	1083	30	61	5.5	2-1/2	7.5	20	90	12.0	2-1/2	16.2	20	90	12.0	2-1/2	16.2
1223	1178	30	67	7.0	2-1/2	9.3	22	90	12.5	2-1/2	16.7	22	90	12.5	2-1/2	16.7
1336	1287	30	73	8.7	2-1/2	11.5	24	90	13.3	2-1/2	17.5	24	90	13.3	2-1/2	17.5
1468	1414	30	80	11.0	2-1/2	14.4	27	90	14.0	2-1/2	18.2	27	90	14.0	2-1/2	18.2
1631	1571	30	90	14.8	2-1/2	19.0	30	90	14.8	2-1/2	19.0	30	90	14.8	2-1/2	19.0
1826	1758	33	90	15.4	2-1/2	19.6	33	90	15.4	2-1/2	19.6	33	90	15.4	2-1/2	19.6
2100	N/A	30	115	5.0	3	7.9	20	172	11.0	3	17.2	17	200	14.8	3	22.9
2500	N/A	30	137	7.5	3	11.4	20	200	15.8	3	23.9	20	200	15.8	3	23.9
3001	N/A	30	164	11.2	3	17.0	25	200	16.7	3	24.8	25	200	16.7	3	24.8
3500	N/A	30	191	16.2	3	23.7	29	200	17.5	3	25.6	29	200	17.5	3	25.6
4001	N/A	33	200	18.7	3	26.8	33	200	18.7	3	26.8	33	200	18.7	3	26.8

BOLD TYPE indicates Low NOx models.

ΔT = Temperature Rise, Degree F@GPM FLOW

GPM = Gallons per Minute Flow

ΔP = Pressure Drop, Foot thru Heat Exchanger

MPS = Minimum Pipe Size, NPT

SHL = System Head Loss

* Must utilize optional cupro-nickel tubes. If over 25 grains per gallon, a water softener/treatment system must be utilized.

Table I: General Specifications Uni-Temp 80 Hot Water Supply Systems

Piping—Domestic Hot Water Supply Heaters

1-1/2" NPT = 70 Ft (0181-0401)

2" NPT = 75 Ft (0514-0824)

2-1/2" NPT = 80 Ft (0926-1826)

3" NPT = 85 Ft (2100-4001)

Table I above provides data for selecting in-line pumps for use in a Uni-Temp 80 system for a single heater and tank according to the following:

Additional pipe fittings will increase the system head loss.

- Flow rates are based on water hardness as measured in grains per gallon.

Soft: 0-4 grains per gallon.

Medium: 5-15 grains per gallon.

Hard: 16-25 grains per gallon.

- Select a pump based on the water hardness, flow, and system head loss.
- If heater is more than two stories above the tank, consult the factory.

- Maximum Flow Rates:

0133 22 GPM

0181-0401 45 GPM

0514-1826 90 GPM

2100-4001 200 GPM

NOTE: GPM flow rates are limited by maximum acceptable velocity through heat exchanger tubes. Heater models 0514 through 1826 may be provided with an integral rear-mounted pump. This must be specified at time of order.

- Pressure drop values (ΔP and SHL) and minimum pipe sizes are for two-pass heaters.

MINIMUM INPUT ADJUSTMENT: Model Types WH have minimum input ratings as specified on their individual rating plates. Minimum input controllers have been pre-set at the factory. Consult with factory representatives if a minimum input problem should occur.

- Sizing based on heater and tank being placed 5 feet apart. The equivalent length of pipe, valves and fittings in the system is as follows:

Piping Diagram—Type WH - Unitemp 80 System

PIPE SIZES		
	BRANCH	MAIN
RAYTHERM		
133	1-1/4"	1-1/2"
181-401	1-1/2"	2"
514-824	2"	3"
926-1826	2-1/2"	3"
2100-4001	3"	4"

5

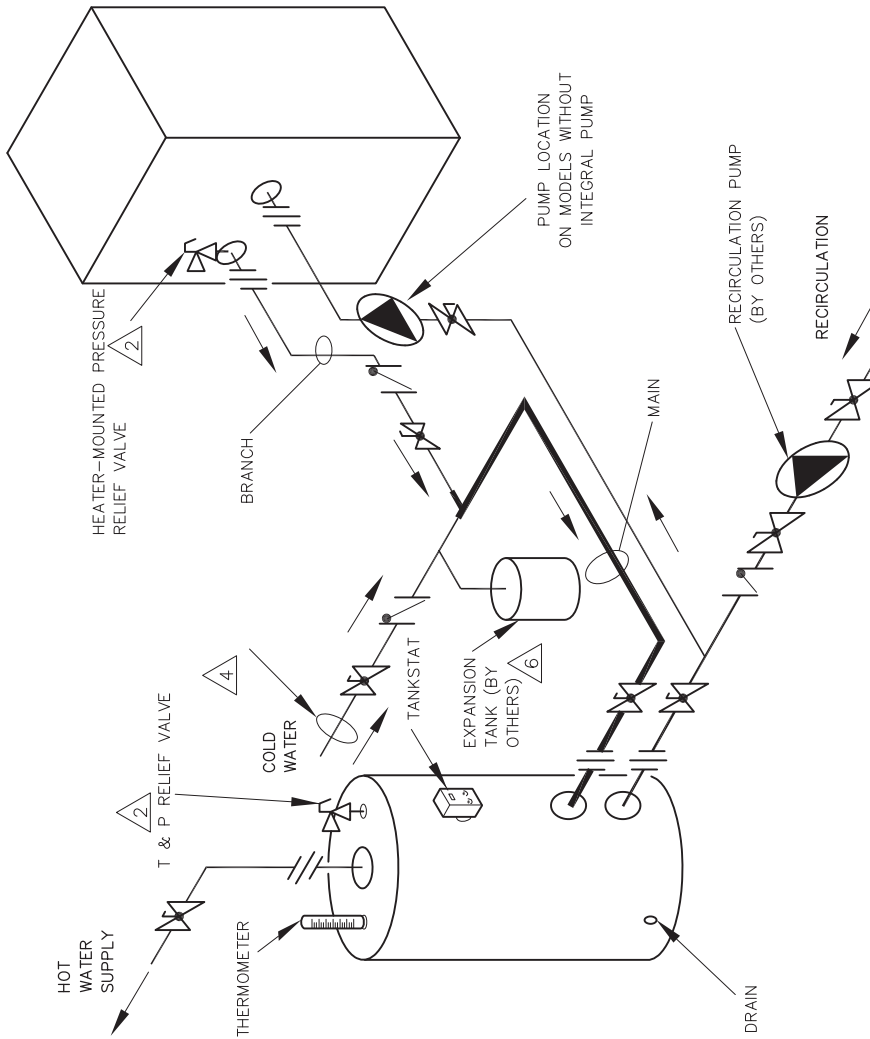

KEY	
	PRESSURE RELIEF VALVE
	PUMP
	UNION
	CHECK VALVE
	BALL VALVE
	THERMOMETER

Raypak

- NOTES:
1. PLUMB SWING CHECK VALVE IN GRAVITY-CLOSED POSITION.
 2. PIPE ALL RELIEF VALVES TO DRAIN, OR AS LOCAL CODES REQUIRE.
 3. LOCATE TEE AS CLOSE AS POSSIBLE TO TANK.
 4. INSTALL COLD WATER BETWEEN HEATER OUTLET AND TANK.
 5. SEE CHART "PIPE SIZES" FOR PIPE SIZES, SIZED AT MAXIMUM FLOW.
 6. PROVIDE FOR THERMAL EXPANSION OF HOT WATER IF A BACKFLOW PREVENTER, CHECK VALVE, WATER METER OR PRESSURE-REDUCING VALVE IS INSTALLED IN THE COLD WATER LINE.
 7. IF HOT WATER SETPOINT EXCEEDS 160F WITH MAX FLOW, SPECIFY "H" BOILERS INSTEAD OF "WH" WATER HEATERS.

Controls—General

Relief Valve

A new combination temperature and pressure (T&P) relief valve, complying with the Standard for Relief Valves and Automatic Gas Shut-Off Devices for Hot Water Supply Systems, ANSI Z21.22, must be installed in the opening provided on top of the storage tank at the time of installation. No valve is to be placed between the relief valve and the storage tank.

The pressure rating of the relief valve must not exceed the 160 maximum working pressure indicated on the water heater rating plate. The BTUH rating of the relief valve must not be less than the BTUH input of the heater.

Connect the outlet of the relief valve to a suitable open drain. The discharge line must pitch downward from the valve to allow complete draining (by gravity) of the relief valve and discharge line. The discharge line should be no smaller than the outlet of the valve. The end of the discharge line should not be threaded or concealed, and should be protected from freezing. No valve of any type, restriction or reducer coupling, should be installed in the discharge line. Local codes shall govern installation of the relief valve.

Pump Time Delay

There are two versions of the Pump Time Delay. The first is an electronic device that allows the operator to set a variable time (3 to 10 minutes) for the pump to run after the heater shuts off. See Fig. 21 (A). The time is factory-set at 7 minutes and it can be re-adjusted in the field.

The second version is a fully enclosed solid state Time Delay Relay (TDR) with a white jumper that selects one of two time delays. See Fig. 21 (B). If the jumper is on pins 6 and 7 (default) the delay time is 5 minutes. If the jumper is not on pins 6 and 7, the time delay is 10 minutes.

In a conventional system, when the tankstat is satisfied, the main gas valve closes, but the pump continues operating. With either time delay relay the heater pump is programmed to continue running for an optimum period of time in order to absorb the residual heat from the combustion chamber and use it in the system. The pump then shuts off until the next call for heat is received from the tankstat.

NOTE: Pump will come on when power is first applied to heater.

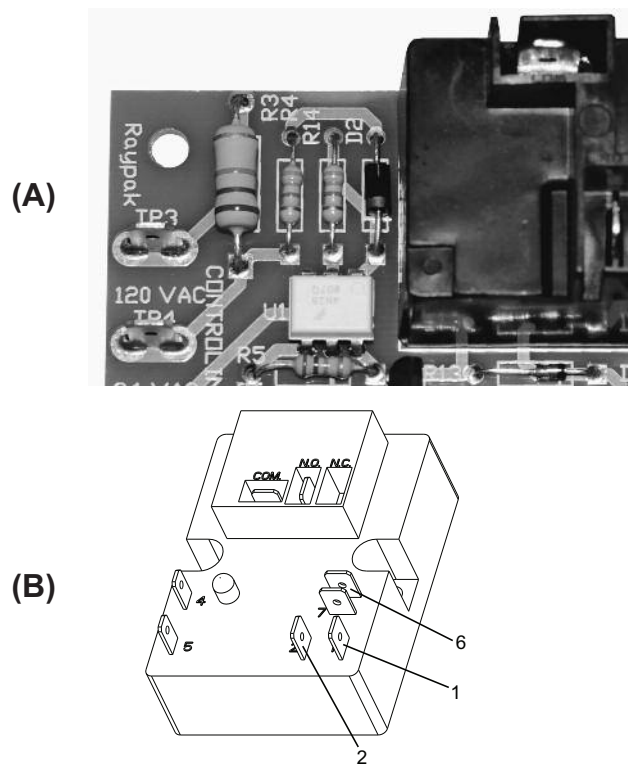

Fig. 21: Economaster Time Delay Relays (TDR)

Electronic Ignition

The intermittent ignition device conserves energy by automatically extinguishing the pilot when desired temperature is reached. When additional heat is needed, the pilot re-ignites electrically, eliminating the fuel costs of maintaining a constant pilot. To ensure safe operation, the gas valve cannot open until the pilot relights and is confirmed.

Model	Gas	Without Lockout	With Lockout
0133-1826	Nat	N/A	Standard
0133-1826	Pro	N/A	Standard
2100-4001	Nat	N/A	Standard
2100-4001	Pro	N/A	Standard

Table J: Electronic Ignition

Operating Controls

On models 0514-1826, models with mechanical modulating controls have one or more Robertshaw Unitrol 7000 Series hydraulic snap on thermostatic combination gas valves. These valves have the pressure regulator and 24-volt operator built-in. The hydraulic actuator will throttle the heater input to adjust the firing rate and meet the required load. This, in effect, prevents costly fuel consumption, as compared to an

on-off cycling heater. The valve has a remote capillary bulb immersed in a well, at the header outlet, to maintain a constant outlet water temperature. When multiple valves are furnished, they can be staged to give greater flexibility of control. Standard factory setting is at position 5. Consult the dial setting tag attached to the control for your desired temperature. See Fig. 22 below.

Robertshaw modulating valve dial setting chart STANDARD FACTORY SETTINGS	
Dial Position	WH2 Temperature Degrees F
LO	110°
1	117°
2	124°
3	130°
4	137°
5	143°
6	150°
7	156°
8	163°
HI	170°

Setting Indicator

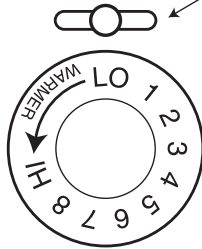

Settings are approximate

The temperature indicator is located on top of the modulator valve next to the "ON/OFF" knob. Set number for desired temperature next to setting indicator.

Fig. 22: Dial Setting Tag

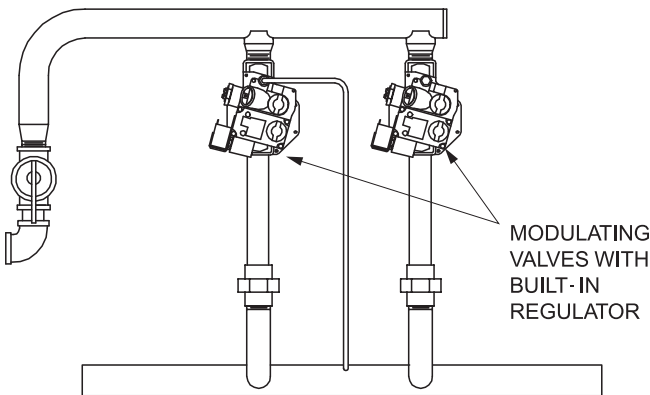

Fig. 23: Mechanical Modulating Valve Location—Models 0724-1336

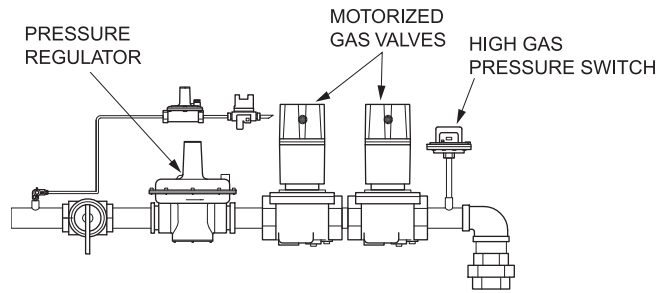

Fig. 24: Motorized Gas Valve Location—Model 3001

Limit Controls

High Limit

The heater is equipped with a manual reset High Limit. Push the reset button and set the limit(s) to 30°F–40°F above desired operating temperature. Maximum setting is 200°F; other options may be available.

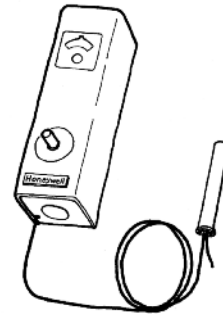

Fig. 25: High Limit

Flow Switch

This dual-purpose control shuts off the heater in case of pump failure or low water condition and is strongly recommended. It is mounted and wired in series to the main gas valve.

NOTE: The flow switch is a safety device and not a control. Do not operate the heater with flows less than the minimums stated in this manual.

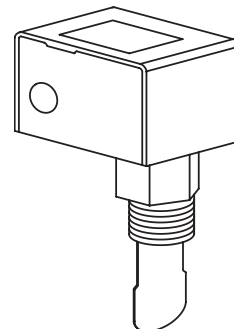

Fig. 26: Flow Switch

100% Pilot Safety

Models 0514-4001 employ electronic devices which close the main gas valve within 8/10 of a second whenever the pilot flame is interrupted. Pilot flame is automatically lit when the device is powered. Unit performs its own safety check and opens the main valve only after the pilot is proven to be lit.

Low Water Cut-Off (Optional)

The low water cut-off automatically shuts down burner whenever water level drops below probe. 5-second (max) time delay prevents premature lockout due to temporary conditions such as power failure or air pockets. Flush float type devices at beginning of each heating season.

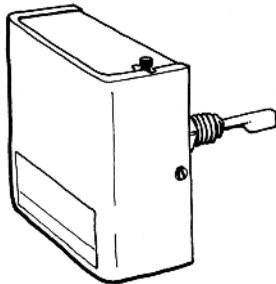

Fig. 27: Low Water Cut-Off

High and Low Gas Pressure Switches (Optional)

These switches sense either high or low gas pressures and automatically shut down burners if abnormal pressures exist.

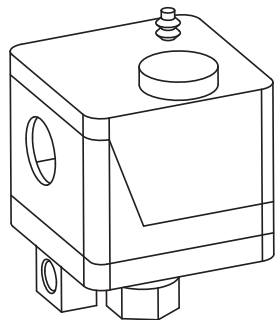

Fig. 28: Gas Pressure Switch

Electrical Connections

WARNING: Turn off the power to the heater before installation, adjustment or service of the heater controls. Failure to do so may result in heater malfunction, property damage, personal injury, or death.

CAUTION: Label all wires prior to disconnection when servicing controls. Wiring errors can cause improper and dangerous operation. Verify proper operation after servicing.

The heater is normally wired for 120 Volts. The voltage is indicated on the tie-in leads. Consult the wiring diagram shipped with the heater in the instruction packet. The "TH" leads are for the remote tank control connection. 24 Volts are supplied to this connection through the heater transformer. DO NOT attach line voltage to the "TH" leads on models 0514-1826. Before starting heater check to ensure proper voltage to heater and pump.

Heater must be electrically grounded in accordance with National Electrical Code ANSI/NFPA No 70.

NOTES:

1. Field install ground wire to inside of junction box.
2. If any of the original wire supplied with the heater must be replaced, it must be replaced with 105°C wire or its equivalent.

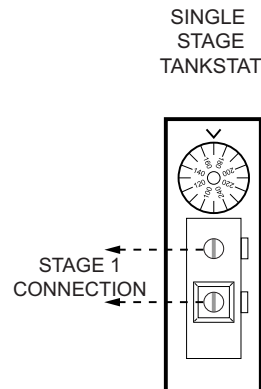

ATTACH STAGE 1 CONNECTIONS ON HEATER TO THE SINGLE STAGE TANKSTAT AS SHOWN IN THE DIAGRAM ABOVE.

Fig. 29: Single-Stage Tankstat

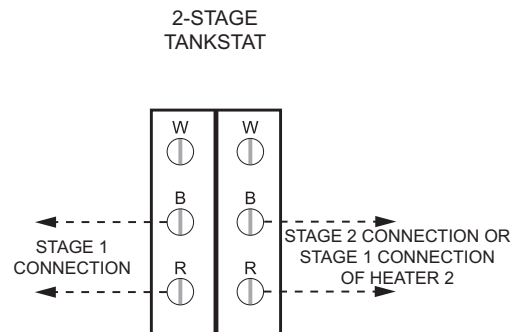

ATTACH STAGE 1 CONNECTIONS ON HEATER TO STAGE 1 CONNECTION ON TANKSTAT.
ATTACH STAGE 2 CONNECTIONS OR STAGE 1 CONNECTION OF HEATER 2 TO STAGE 2 CONNECTION ON TANKSTAT AS SHOWN IN THE DIAGRAM.

Fig. 30: 2-Stage Tankstat (2 On/Off Units)

Location of Controls

0400

WH1, WH2, WH3

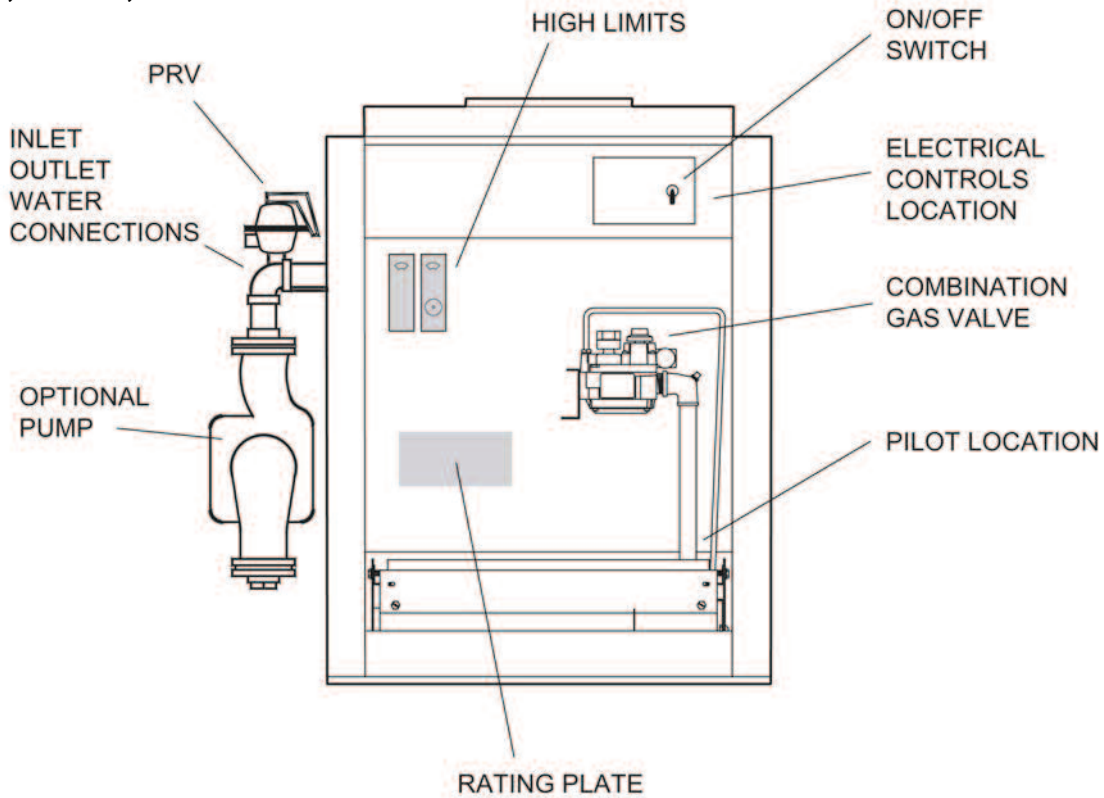

0181 (LOW NOx)

WH1

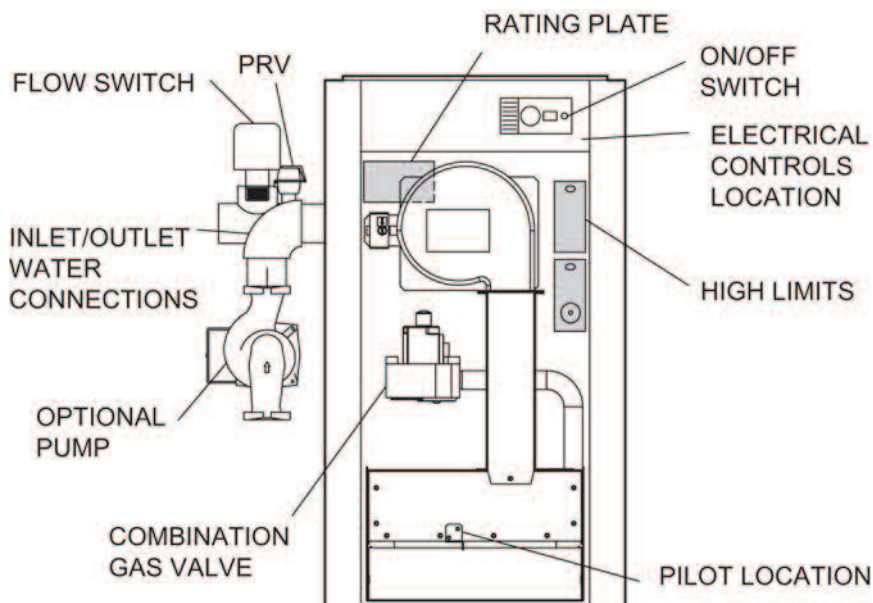

Location of Controls

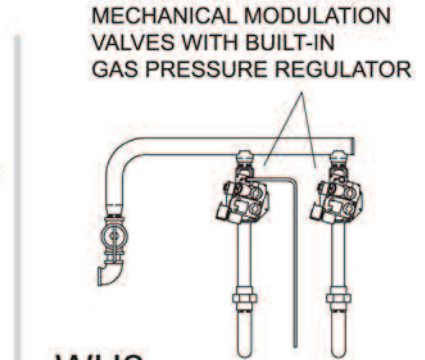
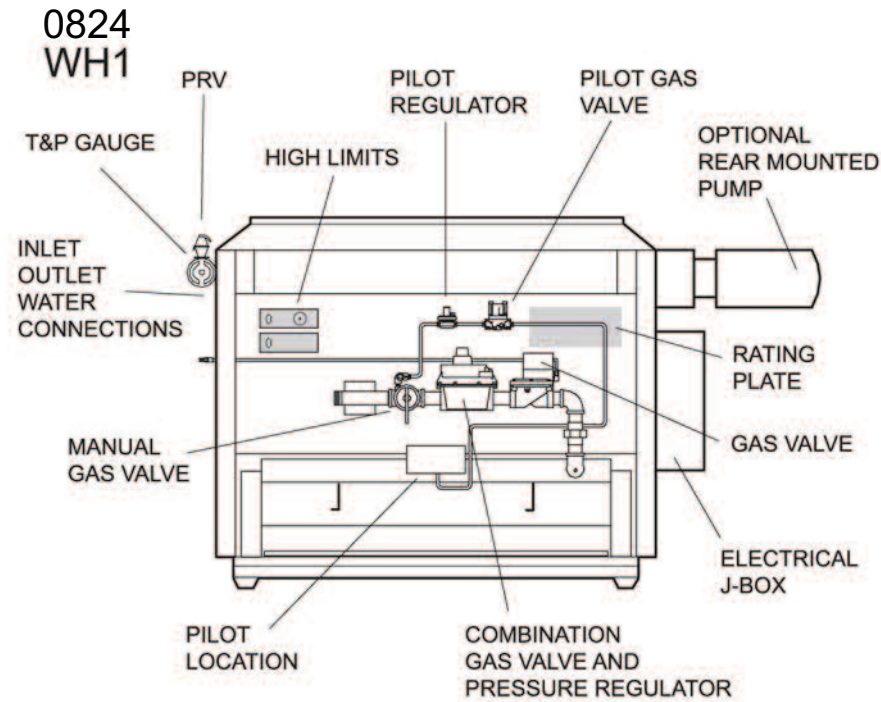

WH2

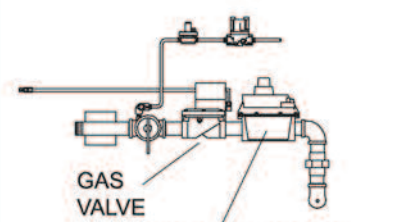

WH3
COMBINATION GAS VALVE AND PRESSURE REGULATOR

AGA DESIGN GAS TRAIN SHOWN. CODE REQUIREMENTS FOR SPECIFIC JURISDICTIONS MAY NECESSITATE CHANGES.

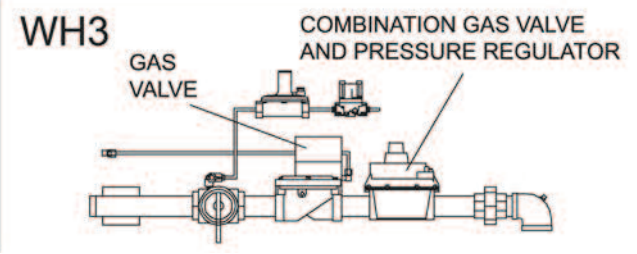
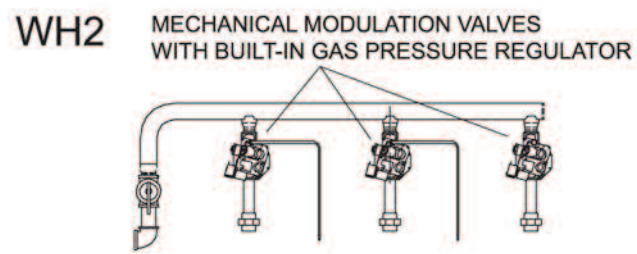
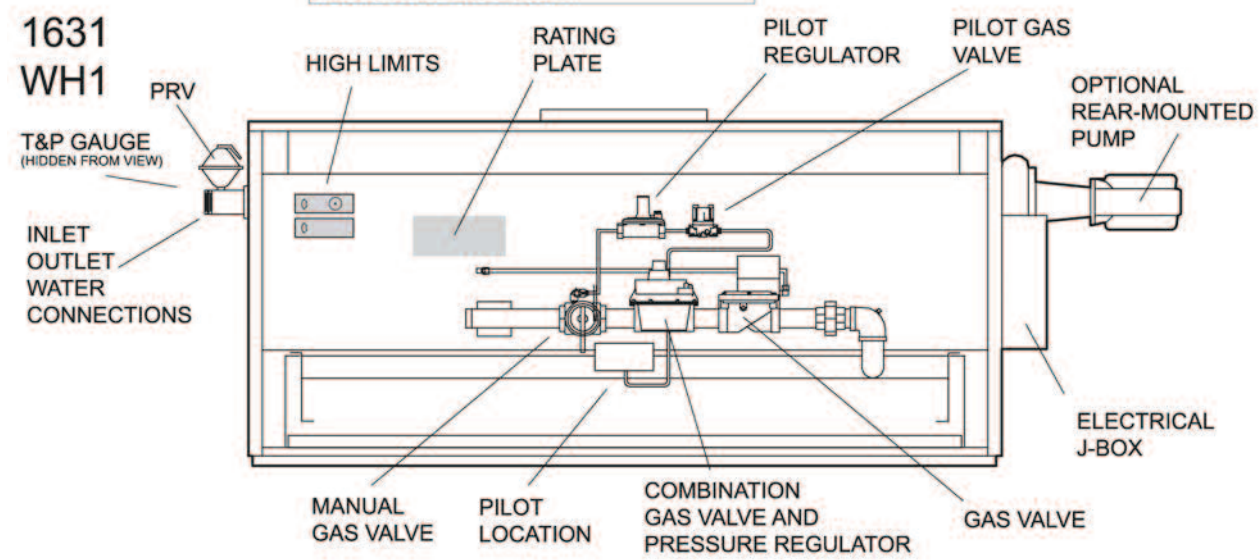

Location of Controls

3001
WH1

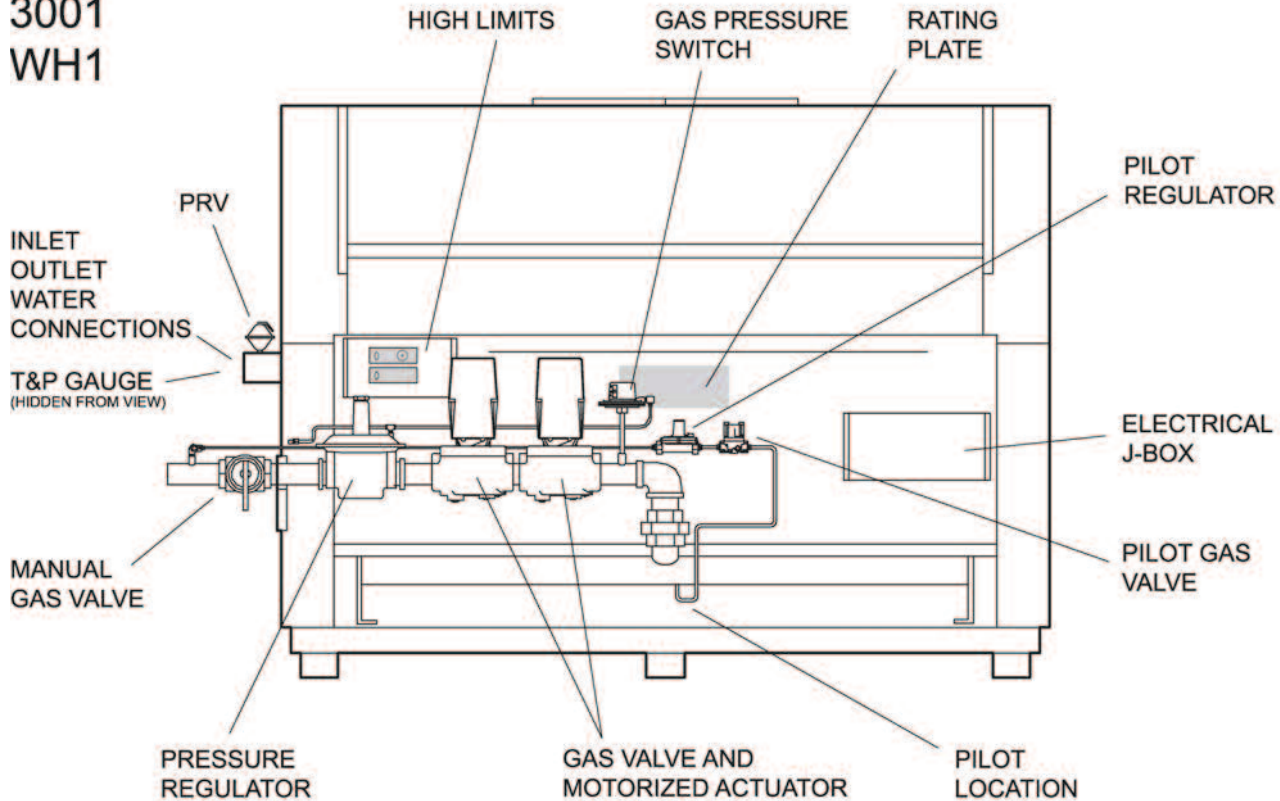

FOR WH2 OR WH3 SYSTEMS, THE ONLY CHANGE IS THE ACTUATOR FOR THE SECOND VALVE.

AGA DESIGN GAS TRAIN SHOWN. CODE REQUIREMENTS FOR SPECIFIC JURISDICTIONS MAY NECESSITATE CHANGES.

START-UP PROCEDURES

Before Start-Up

Safe lighting and other performance criteria were met with the gas manifold and control assembly provided on the heater when the heater underwent tests specified in the latest edition of the ANSI Z21.10.3/CSA 4.3 Standard.

General

Before lighting up a new installation, water should be flowing through the heater. Water pressure regulator should be set to minimum 25 PSI.

WARNING: If you do not follow these instructions exactly, a fire or explosion may result causing property damage, personal injury or loss of life.

CAUTION: Propane gas is heavier than air and sinks to the ground. Exercise extreme care in lighting heater in confined areas.

Initial Start-Up - Pump and Motor

Many pumps are now direct-drive. They have no coupler or bearing assembly. These pumps do not require lubrication. Others require SAE-30 non-detergent oil to lubricate both the motor and the bearing assembly. Check pump motor for type before adding oil.

Clean dust and lint from pump and motor. Check pump coupler and tighten if necessary.

Flush system before putting into operation to ensure that foreign material does not damage pump seals.

CAUTION: Pump must be off to check oil in bearing assembly. Do not run pump without water in system.





LIGHTING INSTRUCTIONS FOR HEATERS WITH ELECTRONIC IGNITION (IID) FOR MODELS WITH MANUAL GAS VALVES



FOR YOUR SAFETY READ BEFORE OPERATING

WARNING: If you do not follow these instructions exactly, a fire or explosion may result causing property damage, personal injury or loss of life.

- A. This appliance is equipped with an ignition device which automatically lights the pilot. Do not try to light the pilot by hand.
- B. BEFORE OPERATING smell all around the appliance area for gas. Be sure to smell next to the floor because some gas is heavier than air and will settle on the floor.
 - WHAT TO DO IF YOU SMELL GAS
 - * Do not try to light any appliance.
 - * Do not touch any electric switch.
 - * Do not use any phone in your building.
 - * Immediately call your gas supplier from your neighbor's phone. Follow the gas supplier's instructions.
- * If you cannot reach your gas supplier, call the fire department.
- C. Use only your hand to push in or turn the gas control knob. Never use tools. If the knob will not push in or turn by hand, do not try to repair it. Call a qualified service technician. Force or attempted repair may result in a fire or explosion.
- D. Do not use this appliance if any part has been under water. Immediately call a qualified service technician to inspect the appliance and to replace any part of the control system and any gas control which has been under water.

OPERATING INSTRUCTIONS

1. STOP! Read the safety information above.
2. Set the thermostat on the lowest setting.
3. Turn off all electric power to the appliance.
4. This appliance is equipped with an ignition device which automatically lights the pilot. Do not try to light the pilot by hand.
5. Remove heater door panel.
6. **For Robertshaw gas valve:** Turn gas control knob clockwise  to "OFF".
For Honeywell Gas Valve: Turn gas control knob clockwise  to "OFF". Make sure knob rests against stop.
For Honeywell Gas Valve: (Model 400 only) Push in gas control knob slightly and turn clockwise  to "OFF". Knob cannot be turned "OFF" unless knob is pushed in slightly. Do not force.
7. Wait five (5) minutes to clear out any gas. Then smell for gas, including near the floor. If you smell gas, STOP! Follow "B" in the safety information previously stated. If you do not smell gas, go to the next step.
8. **For Robertshaw Gas Valve:** Turn gas control knob counter-clockwise  to "ON".

For Honeywell Gas Valve: Turn gas control knob counter-clockwise  from "OFF" until it stops. Push in gas control knob and continue rotating counter-clockwise  to "ON" position. Make sure knob rests against stop.

HONEYWELL GAS CONTROL KNOB SHOWN IN "ON" POSITION
GAS INLET

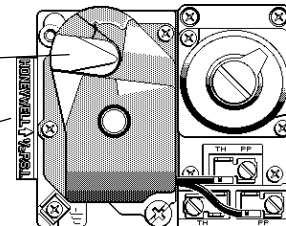

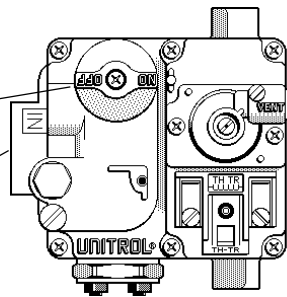

ROBERT SHAW GAS CONTROL KNOB SHOWN IN "ON" POSITION
GAS INLET



9. Replace heater door panel.
10. Turn on all electric power to the appliance.
11. Set thermostat to desired setting.
12. If the appliance will not operate, follow the instructions "To Turn Off Gas To Appliance" and call your service technician or gas supplier.

TO TURN OFF GAS TO APPLIANCE

1. Set the thermostat to the lowest setting.
2. Turn off all the electric power to the appliance if service is to be performed.
3. Remove door panel.
4. **For Robertshaw Gas Valve:** Turn gas control knob clockwise  to "OFF".
5. **For Honeywell Gas Valve:** Turn gas control knob clockwise  to "OFF". Make sure knob rests against stop.
5. Replace heater door panel.

FOR MODELS WITH AUTOMATIC GAS VALVES

1. Close all gas valves. Turn off electric power supply. Wait five (5) minutes.
2. Open manual pilot valve. Turn on electric power. Pilot is automatically lighted.
3. Open main gas valve.
4. Set temperature controls to desired temperature.

TO SHUT DOWN

Close all manual gas valves. Turn off electric power.

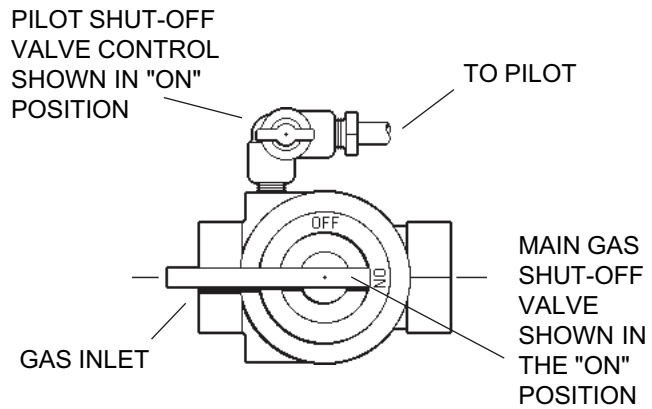

Intermittent Pilot System Checkout Procedure (S8600)

After Start-Up

1. Turn on power to the ignition systems and turn gas supply off.
2. Check ignition module as follows:
 - a. Set the tankstat to call for heat.
 - b. Watch for continuous spark at the pilot burner.
 - c. Time the spark operation. Time must be within the lockout timing period (15 or 90 seconds).
 - d. Turn tankstat down to end call for heat and wait 60 seconds on lockout models before beginning step 3.
3. Turn on gas supply.
4. Set tankstat to call for heat.
5. Systems should start as follows:
 - a. Spark will turn on and pilot gas valve will open at once. Pilot burner should ignite after gas reaches the pilot burner.
 - b. Spark ignition should cut-off when pilot flame is established.
 - c. Main gas valve should open and main burner should ignite after gas reaches the burner port.

INSPECTION PROCEDURES

Burners

Clean main burners and air louvers free of dust, lint and debris. Keep heater area clear and free from combustibles and flammable liquids. Do not obstruct the flow of combustion and ventilation air. Make visual check of burner and pilot flame. Yellow flame indicates clogging of air openings. Lifting or blowing flame indi-

cates excessively high gas pressure. Low flame indicates low gas pressure.

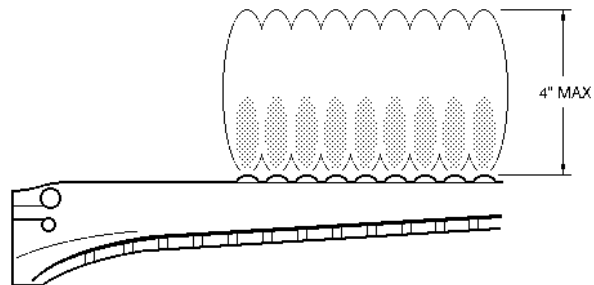

Fig. 31: Typical Main Burner Flame (Atmospheric Models)

Controls

Check all controls to see that they are operational. To check electronic safety (IID models), turn off main burner. Observe pilot burner when shutting off pilot gas. Ignition spark should go on. Main gas valve will also drop out.

High Limit Switch - to check high limit switch, turn dial setting down to a point slightly below the temperature of the water leaving the heater. The reset button should snap out and the burner should shut-off. Reset dial to 30°F to 40°F above desired operating temperature and push reset button. Burner should light.

Inspection Procedures

Inspect on the first and third month after initial startup and then on an annual basis. If problems are found, refer to the Troubleshooting sections of this manual for additional directions.

1. Remove top of heater and inspect heat exchanger for soot and examine venting system.
2. Remove rear header and inspect for scale deposits.
- *3. Inspect pilot and main burner flame and firing rate.
- *4. Inspect and operate all controls and gas valve.
- *5. Visually inspect system for water leaks.
- *6.
 - a. Oil pump motor and bearing assembly, if oil cups are provided.
 - b. Disconnect pump from header and check condition of pump impeller. Check condition of bearing by attempting to move impeller from side to side. Replace any parts showing wear.
 - c. Check pump coupler for wear and vibration.

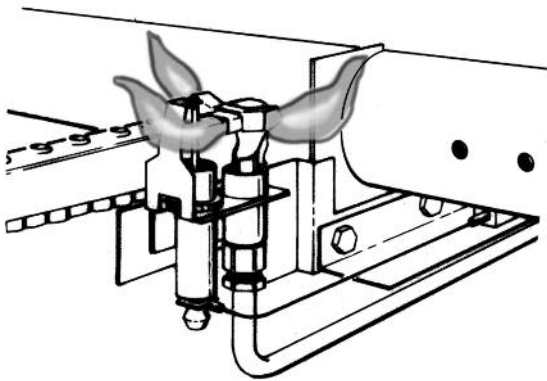

Fig. 32: Pilot Burner Flame—IID (Atmospheric Models)

7. Check flow switch paddle.
8. Clean room air intake openings to ensure adequate flow of combustion and ventilation air.

CAUTION: Combustion air must not be contaminated by corrosive chemical fumes which can damage the heater and void the warranty.

9. Keep heater area clear and free from combustible materials, gasoline, and other flammable vapors and liquids.

*Should be checked monthly. (Takes approximately 15 minutes).

ADDENDA: LOW NO_x HEATERS MODELS 0181 TO 0401

The Raytherm Low NO_x Heater is offered with WH1-On-Off firing (standard) or 2-stage firing (optional). The heaters are certified and tested under the latest edition of the ANSI Z21.10.3/CSA 4.3 standard for hot water heaters. The heater should be installed to meet all local codes, the National Fuel Gas Code ANSI Z223.1, and the National Electrical Code, ANSI/NFPA 70-latest edition.

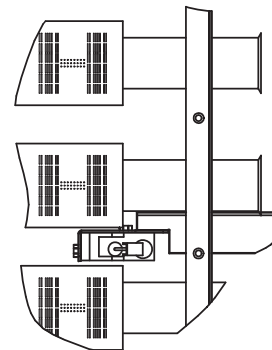

DETAIL A

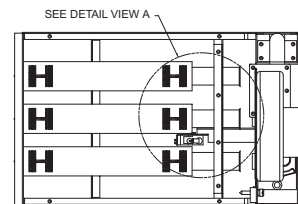

Fig. 33: Burner Detail

Operation

On call for heat, the ignition system, consisting of an electronic spark module, gas pilot system is energized. Providing pilot is proven, blower will start running, the main gas valve will open and the heater will operate. When the operating control is satisfied, the heater will shut down.

Start-Up Procedures (S8610B Ignition Module)

1. Turn on power to the heater with gas supply off.
2. Check ignition module as follows:
 - a. Set the tankstat to call for heat.
 - b. Watch for continuous spark at the pilot burner.

- c. Check the ignition spark operation. Time must be within the lockout timing period (15 or 90 seconds).
 - d. Turn control down to end call for heat and wait 60 seconds on lockout models before beginning step 3.
3. Turn on gas supply.
 4. Set controller to call for heat.
 5. System should start as follows:
 - a. Spark will turn on and pilot gas valve will open and the blower will begin running.
 - b. Heater will operate until call for heat is satisfied.

Burner Adjustment

This burner assembly does not require any primary air adjustments.

Visual Inspection

Flame can be observed through the slot opening above the plenum. Flame color is blue and evenly spread on the top surface of the burner. A visual inspection should be made monthly of the burners. In case flame lifting is observed on the burner, check gas pressure on manifold and static pressure in plenum. Gas pressure in manifold should be 3.9" WC and static pressure in plenum should be greater than 0.5" WC.

Electrical

Be sure that electrical service to the heater has proper overload fuse or circuit breaker protection, and wire size and connections comply with all applicable codes.

High Gas Pressure Switch

Pressure switch senses high pressure and automatically shuts down burner if abnormal pressure exists.

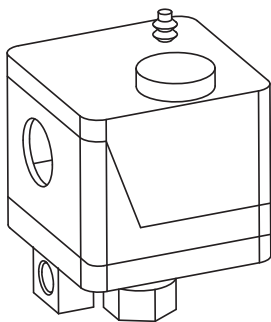

Fig. 34: Gas Pressure Switch

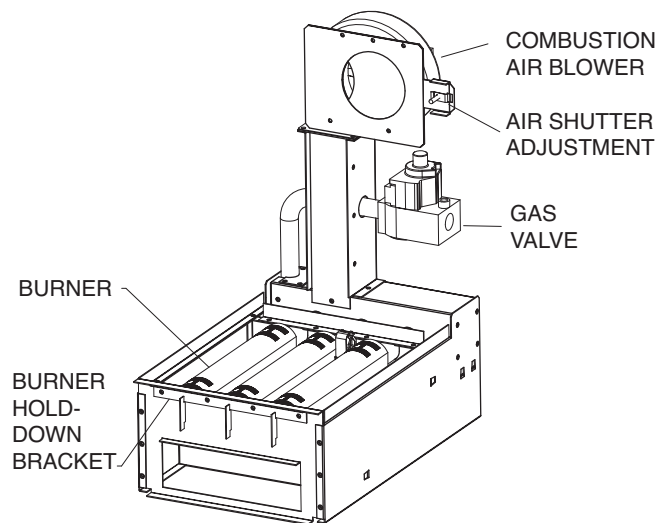

Fig. 35: Low NOx Burner Tray Assembly

Burner Tray Removal

1. Shut-off main electrical power switch to heater.
2. Shut-off gas upstream of heater.
3. Remove front door.
4. Disconnect gas line from gas valve.
5. Remove (2) screws that mount burner tray to unit, and (4) screws that secure gas valve to jacket.
6. Disconnect wires that terminate at gas valve.
7. Unscrew (4) screws that secure the control box.
8. Disconnect pilot wire from the ignition module.
9. Disconnect wire harness from the combustion blower.
10. Carefully slide out the burner tray assembly.
11. Reverse above procedure to reinstall.

Gas Valve Removal

1. Shut-off main electrical power switch to heater.
2. Shut-off gas supply to the heater.
3. Remove front door.
4. Disconnect gas line from gas valve.
5. Disconnect wires, pilot tubing and bleed line, if required.
6. Remove (2) screws that secure gas valve to jacket.
7. Turn vertical gas pipe from manifold slightly and unscrew gas valve.
8. Reverse above procedure to re-install.

Main Burner And Orifice Removal

1. Remove burner tray. (See Burner Tray Removal procedure on page 34.)
2. Remove (8) screws from the hold-down brackets.
3. Remove (8) screws from the left and right sides of the manifold assembly. Detach the manifold assembly from the burner tray assembly.
4. Use a long $\frac{1}{2}$ " socket wrench to remove orifices from the gas manifold.
5. Remove burners by raising the bracket on the back end of the burners up and out of their slots.
6. Reverse above procedure to re-install.

Pilot Removal

1. Disconnect pilot tubing from gas valve.
2. Remove (4) screws from control box. Open the control box.
3. Remove the pilot wire from the ignition wire.
4. Remove (2) screws that mount the pilot bracket to the air manifold assembly.
5. Pull the pilot bracket downwards and outwards.
6. Reverse above procedure to re-install.

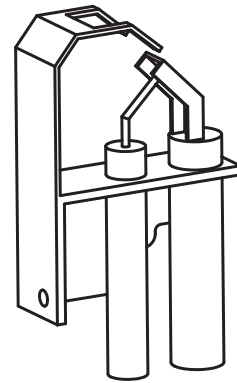

Fig. 36: IID Pilot

Combustion Fan Removal

1. Remove burner tray. (See Burner Tray Removal procedure on page 34.)
2. Remove (4) screws that mount the combustion blower to the manifold assembly.
3. Reverse above procedure to re-install.

TROUBLESHOOTING

WARNING—HIGH VOLTAGE: For qualified technicians ONLY.

Electrical—Electronic Ignition IID

Intermittent Pilot System Honeywell S8600

NOTE: Some heaters may be equipped with an ignition module that shuts off pilot gas if pilot fails to light. To reset, interrupt power to heater.

NOTE: Before troubleshooting, familiarize yourself with the start-up and checkout procedure.

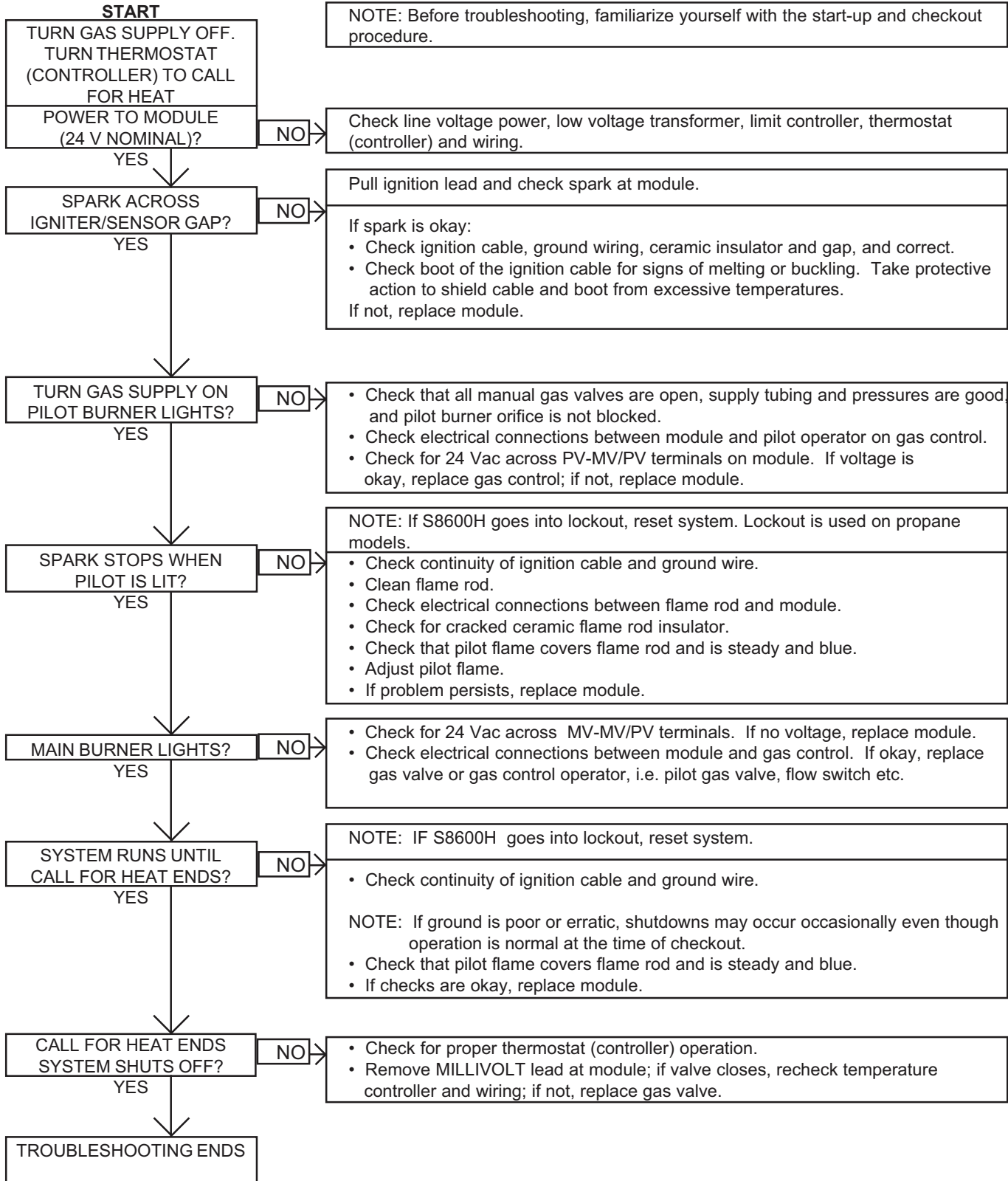

Mechanical

MECHANICAL PROBLEM	POSSIBLE CAUSE	CORRECTIVE ACTION
When heater is turned on nothing happens.	No power to the heater.....	Check the circuit breaker, outdoor controller, etc., upstream of heater.
	Bad transformer.....	If power to Leads L1 and L2 of transformer, but no power on 24V side, replace.
	Inoperative thermostat.....	Jumper thermostat, replace with new if heater fires.
	Inoperative toggle switch.....	If power to toggle switch, but not through switch, replace.
	Inoperative relay.....	If power to relay, but not operating, replace.
Thermostat in "ON" position causes relay and pump to operate, but heater does not fire.	Main gas valve closed.....	Open valve.
	Plugged bleed line on gas valve or gas pressure regulator.....	Loosen bleed line and clean.
	Broken pump coupler.....	Replace coupler. Inspect bearing assembly, and if frozen, lubricate or replace.
	Shutdown by low water cut-off, caused by air.....	Bleed air from system.
	Gas valve defective.....	Check for power to gas valve. If valve has power but will not open, check vent tube for blockage. If clear, replace valve.
Continuous shut down of manual reset High Limit.	Temperature setting too low.....	Reset High Limit to higher temperature.
	Low water flow.....	Check system water pumps.
	Interrupted pump operation.....	Check pump oil if necessary.
	Modulating control set too high.....	Reset modulator to a lower setting.
	Mechanical modulating control.....	Check and replace if necessary.
Sooting CAUTION-Soot may be combustible. Wet down and exercise caution when cleaning.	Air starvation.....	Refer to installation instructions regarding combustion air requirements.
	Condensation.....	Set bypass valve to prevent heater inlet temperature from dropping below 105° F.
	Toxic fumes which cause a chemical reaction with copper tubes or destroy combustion.....	Remove all sources of fumes, such as freon or chloride, or isolate the heater.
Continuous shut down of low water cut-off or flow switch.	Improper venting.....	Follow recommended vent installation instructions.
	Insufficient system flow.....	Check pumps and piping.
	Low water due to leaking.....	Inspect for leaking and repair.
	Air in system.....	Inspect for leakage and repair. Install an automatic air vent.
	Line strainer dirty.....	Clean.
Low flame.	Lime in Heat Exchanger.....	Ream tubes.
	Low gas supply.....	Debris in gas line (pipe dope, rocks, etc.). Gas line too small. Improper size gas meter. Gas regulator adjustment.
	Insects or debris clogging.....	Clean burners.
	Burner intake ports low gas pressure....	Adjust gas pressure.
	Venting or combustion air.....	Refer to installation instructions regarding combustion air requirement.
Outer jacket very hot (blistered paint)	Broken refractory.....	Replace refractory panels.
Combustion fan not running. (If applicable)	Fan relay.....	Replace fan relay.
	Fan.....	Loose wire connection. Failed fan motor.

WIRING DIAGRAMS

Wiring Diagram—W2/WH2 133

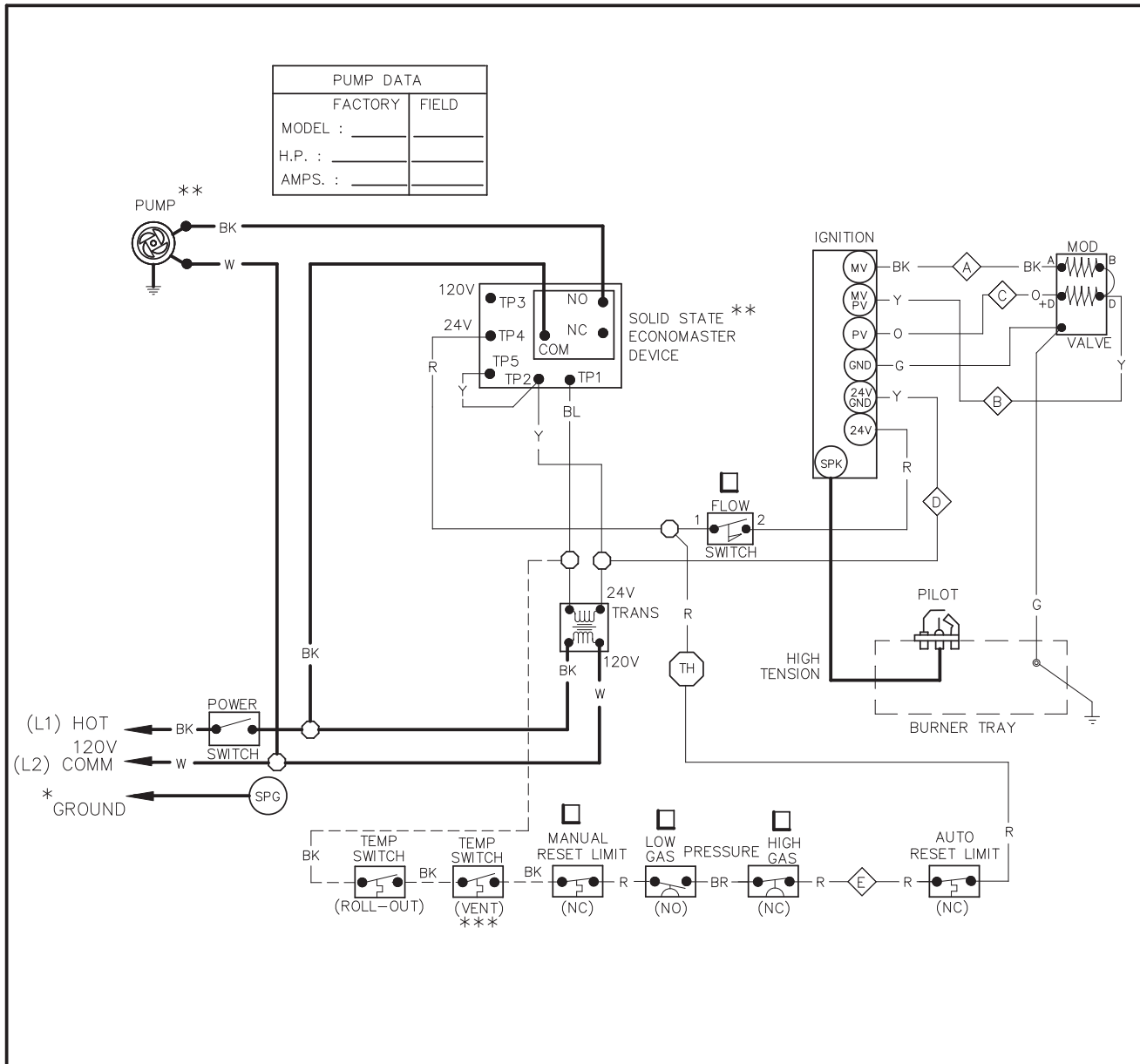

PUMP DATA	
FACTORY	FIELD
MODEL :	
H.P. :	
AMPS. :	

PUMP **

SOLID STATE **
ECONOMASTER
DEVICE

IGNITION

MOD VALVE

FLOW SWITCH

24V TRANS

PILOT

HIGH TENSION

BURNER TRAY

TEMP SWITCH (ROLL-OUT)

TEMP SWITCH (VENT) ***

MANUAL RESET LIMIT (NC)

LOW GAS PRESSURE (NO)

HIGH GAS (NC)

AUTO RESET LIMIT (NC)

NOTES: * USE GROUND CONNECTION PROVIDED. FAILURE TO PROVIDE PROPER GROUND MAY RESULT IN LOCK-OUT ALL GROUND \perp TERMINATE AT SPG .

** PUMP USED MUST BE RATED 10 AMPS MAX OR 3/4 HP MAX. PUMP DELAY ADJUSTABLE BETWEEN 3 AND 10 MINUTES.

***VENT TEMP SWITCH ONLY PROVIDED ON INDOOR BOILERS

\diamond - \diamond CONNECTIONS FOR OPTIONAL E-4 ALARM PANEL.

CHECK CONTROLS PROVIDED (WIRED AS SHOWN)

IF ANY OF THE ORIGINAL WIRE AS SUPPLIED MUST BE REPLACED, IT MUST BE REPLACED WITH ITS EQUIVALENT, 105°C OR 150°C AS NOTED.

KEY	
—	24V 105°C
- - - -	24V 150°C
—	120V 105°C
- - - -	120V 150°C
\bigcirc	WIRE NUT
SPG	GROUND
BK	BLACK
BR	BROWN
R	RED
O	ORANGE
Y	YELLOW
G	GREEN
BL	BLUE
V	VIOLET
W	WHITE

CHECKED BY:	
APPROVED BY:	
ORIG E.O. 2725	
11/17/92	
CHG E.O. 5223	
8/8/14	

WIRING DIAGRAM IID ECONOMASTER FIRING MODE — MECHANICAL MODULATING	
BOILER INPUTS: 136,000 BTUH	
BOILER SIZE: 133A	BOILER TYPE: WH2

152331	8
---------------	----------

Wiring Diagram—WH1 0181/0261

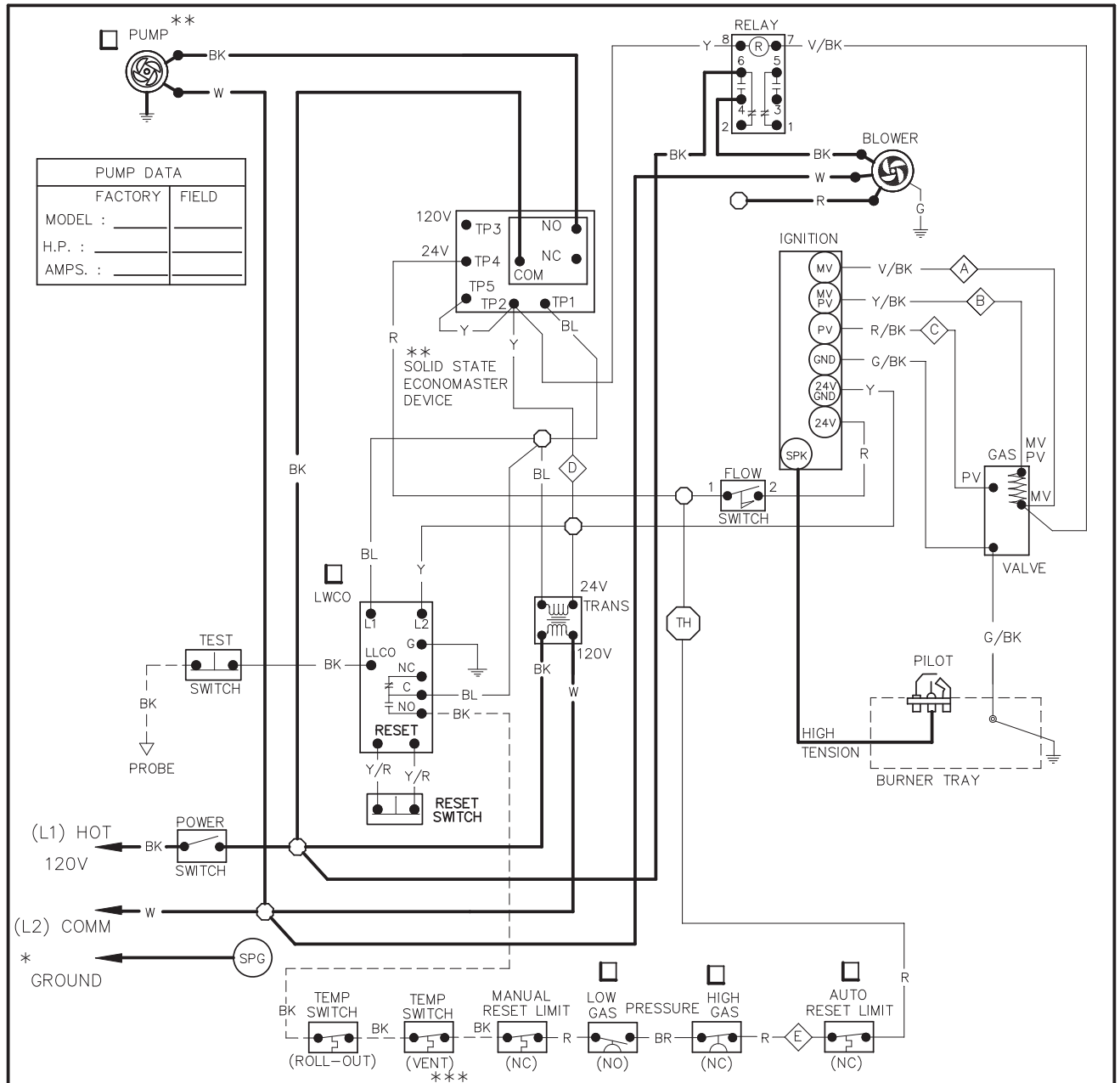

NOTES: * USE GROUND CONNECTION PROVIDED. FAILURE TO PROVIDE PROPER GROUND MAY RESULT IN LOCK-OUT ALL GROUND \perp TERMINATE AT \oplus .

****** PUMP USED MUST BE RATED 10 AMPS MAX OR 3/4 HP MAX. PUMP DELAY ADJUSTIBLE BETWEEN 3 AND 10 MINUTES.

******* VENT TEMP SWITCH ONLY PROVIDED ON INDOOR BOILERS

⬠ — ⬠ CONNECTIONS FOR OPTIONAL E-4 ALARM PANEL.

CHECK CONTROLS PROVIDED (WIRED AS SHOWN)

REPLACE WIRING WITH 105°C WIRE OR ITS EQUIVALENT AND 150°C AS NOTED.

CHECKED BY:
APPROVED BY:
ORIG E.O. 3311
8/17/00
CHG E.O. 5223
08/13/14

WIRING DIAGRAM IID ECONOMASTER LOW NOX FIRING MODE — ON/OFF

INPUTS: 181,000 THRU 264,000 BTUH

SIZE: **181A/261A**

TYPE: **WH1**

152522 **6**

Wiring Diagram—WH1 0331/0401

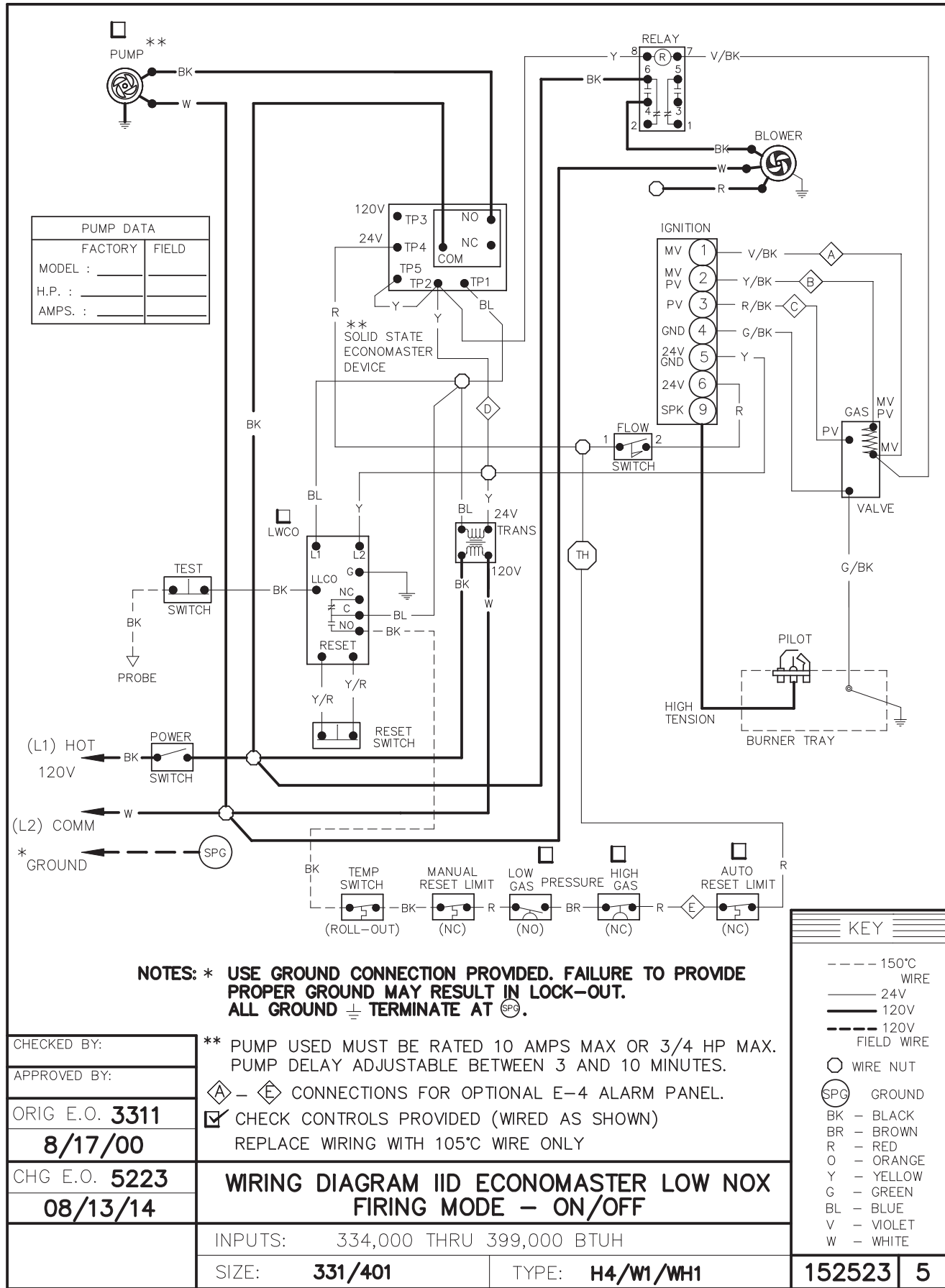

Wiring Diagram—WH1 0824-1826

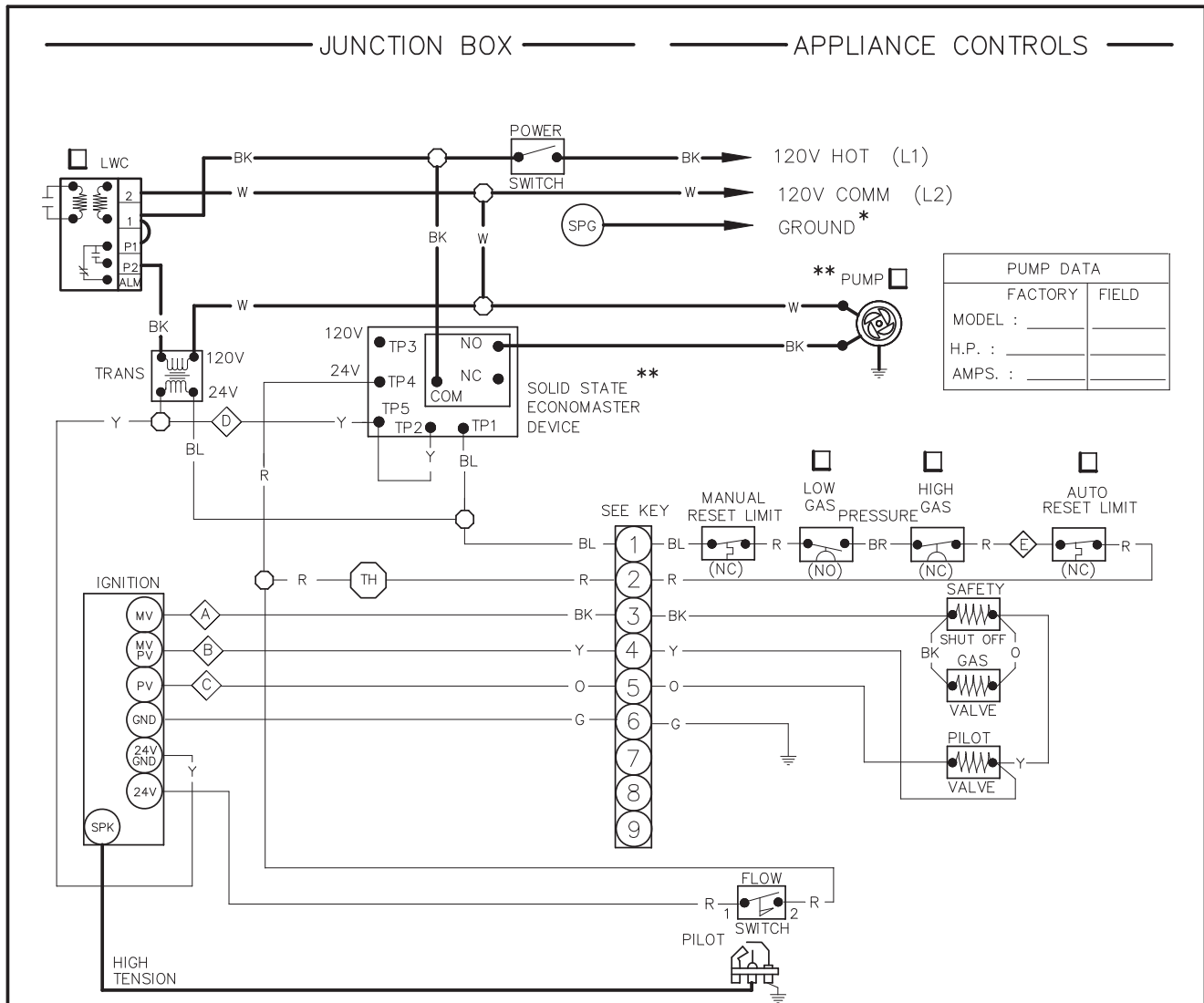

PUMP DATA	
FACTORY	FIELD
MODEL :	
H.P. :	
AMPS. :	

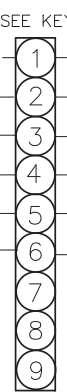

KEY		
—	24V	105°C
—	120V	105°C
○	WIRE NUT	
⊕	GROUND	
BK	BLACK	
BR	BROWN	
R	RED	
O	ORANGE	
Y	YELLOW	
G	GREEN	
BL	BLUE	
V	VIOLET	
W	WHITE	
PLUG (ACTUAL)		
FRONT VIEW		

NOTES: * USE GROUND CONNECTION PROVIDED. FAILURE TO PROVIDE PROPER GROUND MAY RESULT IN LOCK-OUT ALL GROUND \perp TERMINATE AT \oplus .

** PUMP USED MUST BE RATED 10 AMPS MAX OR 3/4 HP MAX. PUMP DELAY ADJUSTABLE BETWEEN 3 AND 10 MINUTES.
 ◇ — ◇ CONNECTIONS FOR OPTIONAL E-4 ALARM PANEL.
 CHECK CONTROLS PROVIDED (WIRED AS SHOWN) REPLACE WIRING WITH 105°C WIRE ONLY

APPROVED BY:
CHECKED BY:
ORIG E.O. 2397
07/08/88
CHG E.O. 5223
4/23/14

WIRING DIAGRAM IID/ECONOMASTER FIRING MODE — ON/OFF	
BOILER INPUTS:	825,000 THRU 1,826,000 BTUH
BOILER SIZE:	824-1826
BOILER TYPE:	H4/W1

152170	7
--------	---

Wiring Diagram—WH1 2100-2500

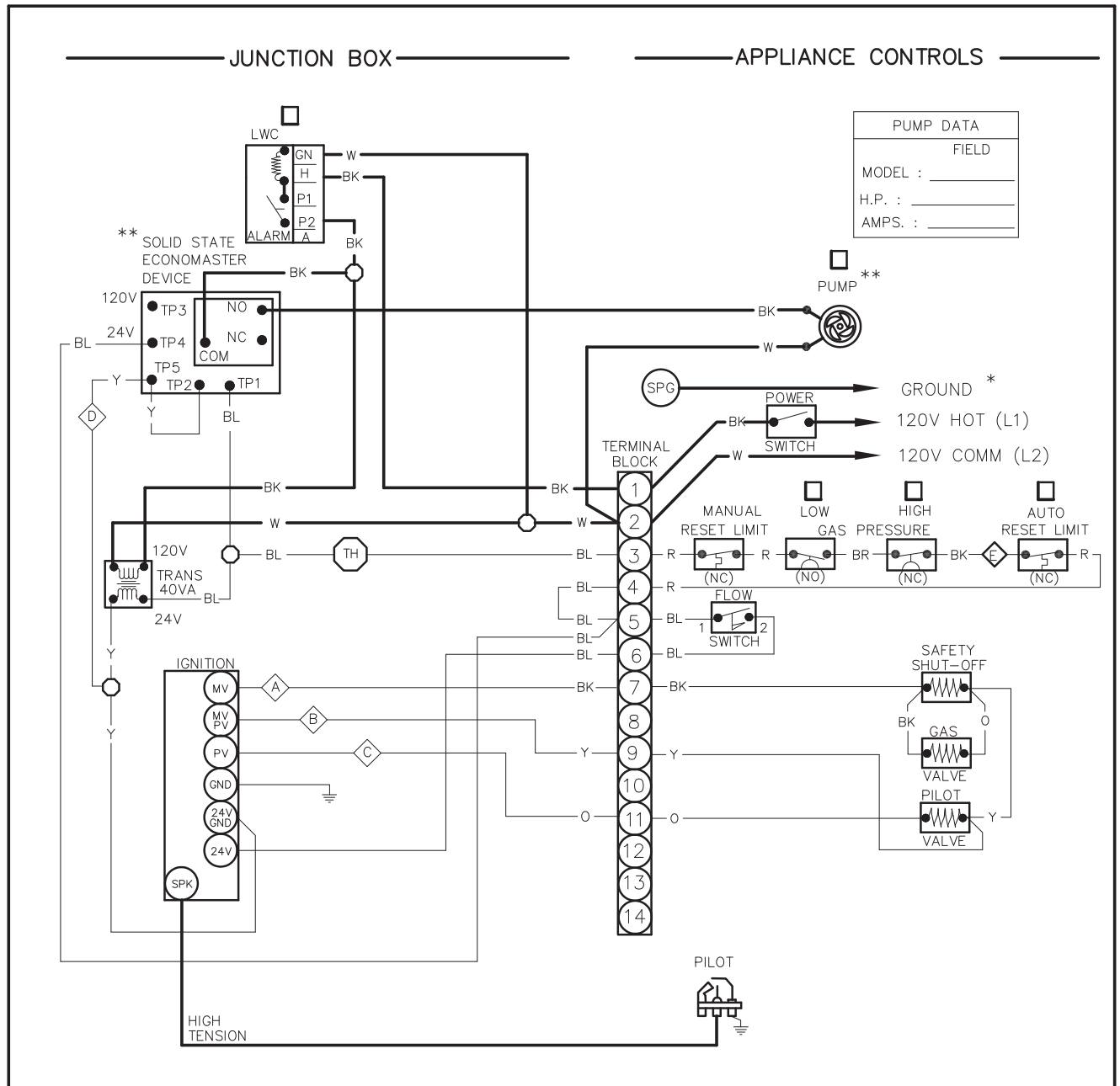

PUMP DATA	
FIELD	
MODEL :	_____
H.P. :	_____
AMPS. :	_____

NOTES: * USE GROUND CONNECTION PROVIDED. FAILURE TO PROVIDE PROPER GROUND MAY RESULT IN LOCK-OUT ALL GROUND \perp TERMINATE AT SPG .

****** PUMP USED MUST BE RATED 10 AMPS MAX OR 3/4 HP MAX. PUMP DELAY ADJUSTABLE BETWEEN 3 AND 10 MINUTES.
 \triangle - \diamond CONNECTIONS FOR OPTIONAL E-4 ALARM PANEL.
 CHECK CONTROLS PROVIDED (WIRED AS SHOWN) REPLACE WIRING WITH 105°C WIRE ONLY

CHECKED BY:	
APPROVED BY:	
ORIG E.O. 1947	07/05/84
CHG E.O. 3883	09/20/06
Raupak	

WIRING DIAGRAM IID ECONOMASTER FIRING MODE - ON/OFF	
BOILER INPUTS: 2,100,000 THRU 2,499,000 BTUH	
BOILER SIZE: 2100-2500	BOILER TYPE: H4/W1

KEY	
	24V 105°C
	120V 105°C
	WIRE NUT
	GROUND
BK	BLACK
BR	BROWN
R	RED
O	ORANGE
Y	YELLOW
G	GREEN
BL	BLUE
V	VIOLET
W	WHITE

151998 | 10

Wiring Diagram—WH1 3001-4001

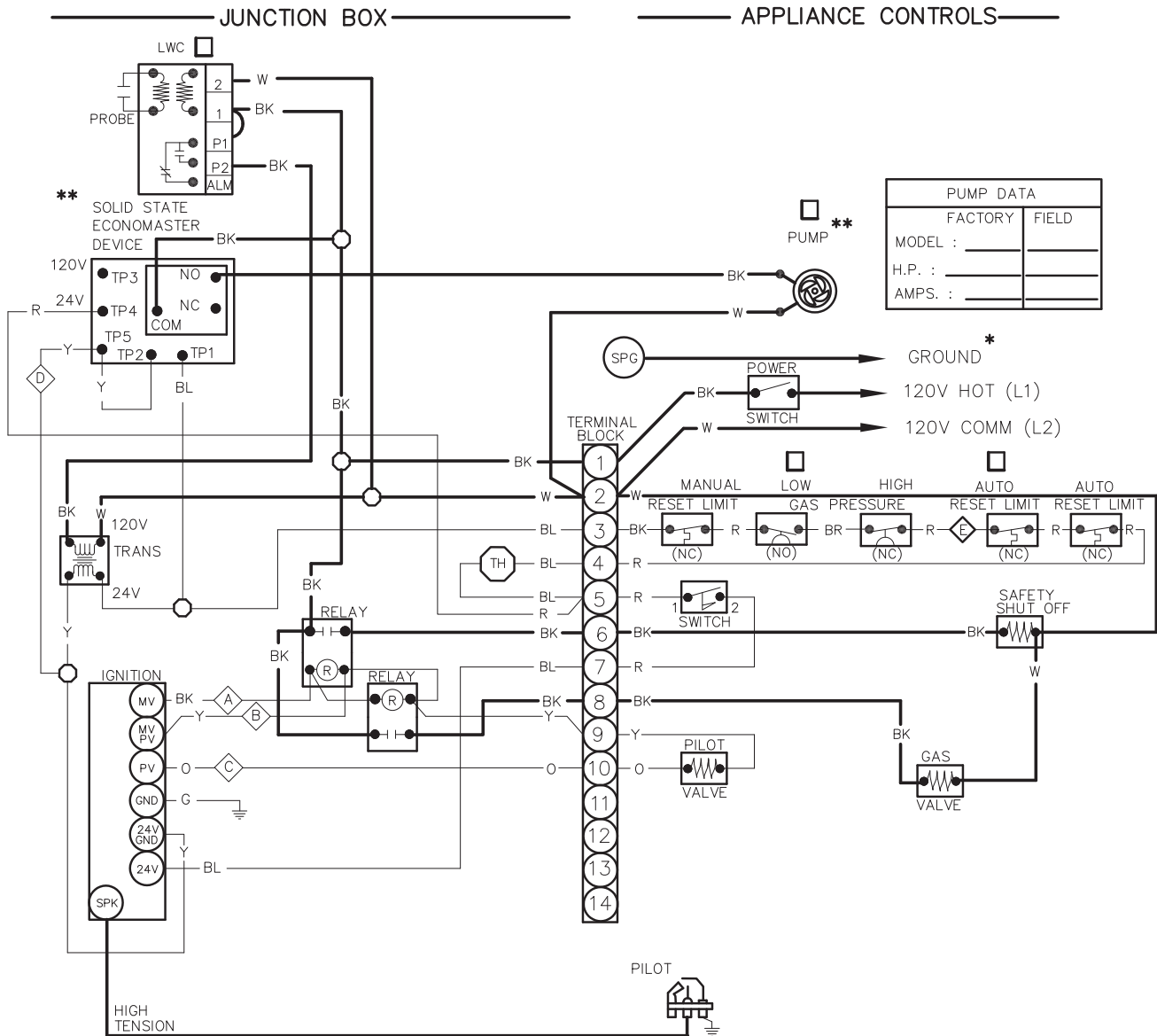

NOTES: * USE GROUND CONNECTION PROVIDED. FAILURE TO PROVIDE PROPER GROUND MAY RESULT IN LOCK-OUT ALL GROUND \perp TERMINATE AT SPG .

- ** PUMP USED MUST BE RATED 10 AMPS MAX OR 3/4 HP MAX. PUMP DELAY ADJUSTABLE BETWEEN 3 AND 10 MINUTES.
- \diamond - E CONNECTIONS FOR OPTIONAL E-4 ALARM PANEL.
- CHECK CONTROLS PROVIDED (WIRED AS SHOWN) REPLACE WIRING WITH 105°C WIRE ONLY

KEY	
—	24V 105°C
—	120V 105°C
\bigcirc	WIRE NUT
SPG	GROUND
BK	BLACK
BR	BROWN
R	RED
O	ORANGE
Y	YELLOW
G	GREEN
BL	BLUE
V	VIOLET
W	WHITE

CHECKED BY:
APPROVED BY:
ORIG E.O. 1947
07/05/84
CHG E.O. 3883
09/20/06
<i>Raupak</i>

WIRING DIAGRAM IID ECONOMASTER FIRING MODE - ON/OFF

BOILER INPUTS: 3,000,000 THRU 4,000,000 BTUH

SIZE: **3001-4001** TYPE: **H4/W1**

151994 13

Troubleshooting—Pumps

Failure To Pump

1. Pump not properly primed.
2. Wrong direction of rotation.
3. Speed too low.
4. Total head too high.

Reduced Capacity and/or Head

1. Air pockets or leaks in suction line.
2. Clogged impeller.
3. Foot valve strainer too small or clogged.
4. Excessive suction lift (over 15 feet).
5. Insufficient positive suction head (for hot water).
6. Total head more than that for which pump is intended.
7. Excessively worn impeller and wearing rings.

Rapid Wear of Coupling

1. Misalignment or a bent shaft.
2. Sagging motor mounts (over-oiling).

Pump Loses Prime

1. Air leaks in suction line.
2. Excess air in water.
3. Water seal in stuffing box not functioning.
4. Excessive suction lift and pump operating too near shut-off point.

Overloaded Driving Unit

1. Head much lower than that for which pump is designed.
2. Speed too high or higher than that contemplated.

Mechanical Troubles and Noise

1. Misalignment.
2. Excessive suction lift or vapor binding (hot water).
3. Bent shaft and/or damaged bearings.
4. Suction and discharge piping not properly supported and anchored.

SERVICE AND MAINTENANCE PROCEDURES

Tube Cleaning

Establish a regular inspection schedule, the frequency depending on the local water condition and severity of service. Do not let the tubes clog up solidly. Clean out deposits over 1/16" in thickness.

The heater may be cleaned from the side opposite the water connections as shown, without breaking pipe connections. It is preferable, however, to remove both headers for better visibility through the tubes and to be sure the residue does not get into the system. Note that you do not remove the top pan or the heat exchanger generally. After reaming with the auger, mount the wire brush and clean out the debris remaining in the tubes. Another method is to remove the heat exchanger, ream tubes and immerse heat exchanger in noninhibited de-scale solvent.

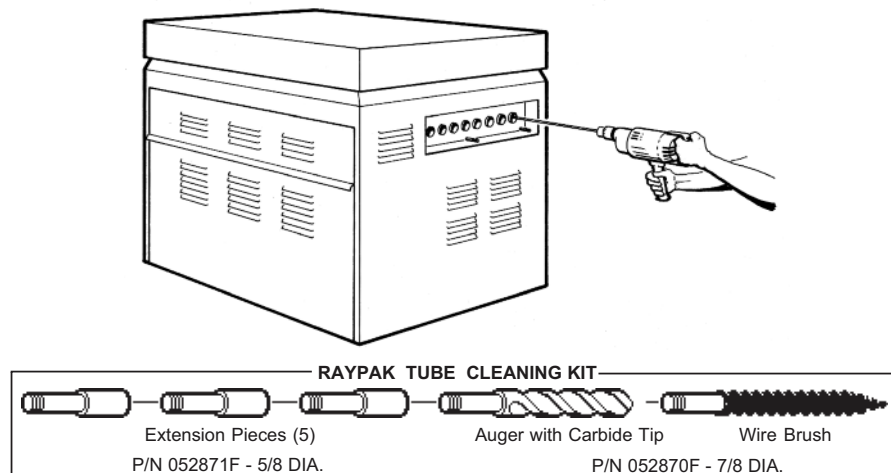

Fig. 37: Raypak Tube Cleaning Procedure

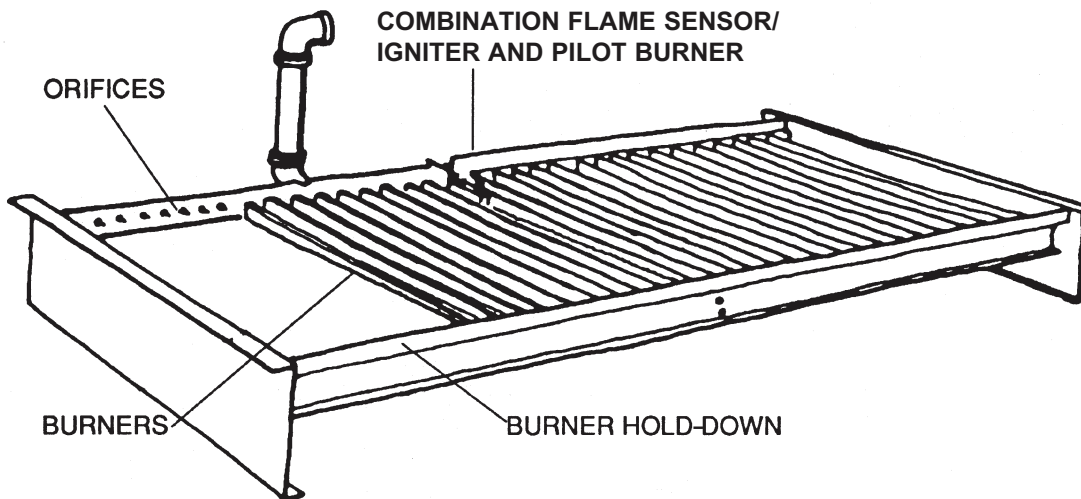

Fig. 38: Typical Burner Tray Illustrated

Burner Tray Removal

1. Shut-off power and gas supply to the heater. Disconnect union(s) and pilot tubing, then loosen and remove burner hold-down screws.
2. Disconnect wires at gas valve and slide burner drawer out.

Gas Valve Removal

1. Shut-off gas supply to the heater. Remove gas piping to gas valve inlet.
2. Disconnect wires, pilot tubing and bleed line, if required.
3. Turn vertical gas pipe from manifold slightly and unscrew gas valve.
4. Reverse above procedure to re-install.

Gas Valve Adjustment - Robertshaw (Invensys) 7000 Series 2-Stage Gas Valve with Solenoid Valve

NOTE: Attach a manometer and check the manifold pressures –both high fire and low fire– before making any adjustments.

1. Turn the heater off.
2. Remove the 3/8" nut or the #10 Torx screw.
3. Lift solenoid valve up, keeping the wires connected to the solenoid valve.
4. If only low fire adjustment is needed, go to Step 9.
5. Using a 3/8" wrench, carefully remove the aluminum cap that was under the solenoid valve-count # of turns when removing the cap. Be careful not to drop the cylinder (weight) or the small spring that is under the cap –see Fig. 39.

6. Remove the spring and store in a safe place.
7. Using an Allen wrench, turn the screw clockwise to increase or counterclockwise to decrease high fire manifold pressure –see Fig. 39.
8. Install the spring, weight and aluminum cap –tighten the cap using same # of turns as was used in removing the cap.
9. For low fire adjustment, tighten the aluminum cap to increase and loosen to decrease low fire manifold pressure.
10. Install 2-stage solenoid valve and turn heater on, check manifold pressures.
11. Repeat steps 3 to 10 until correct manifold pressures are obtained.
12. Secure 2-stage solenoid valve by tightening the 3/8" nut or #10 Torx screw.

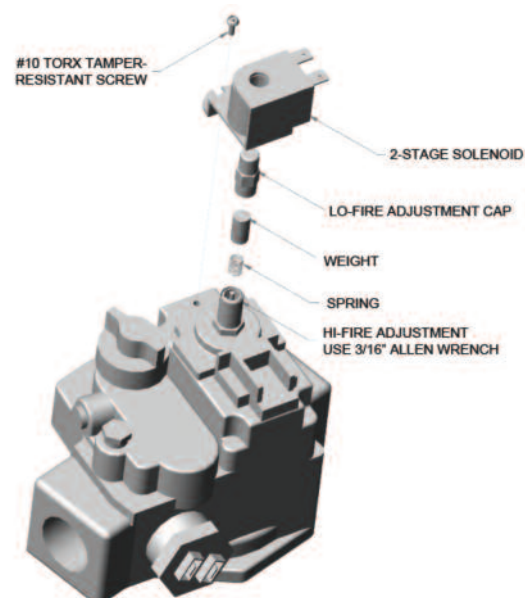

Fig. 39: 2-Stage Gas Valve Adjustment (Invensys)

Main Burner and Orifice Removal

1. Remove screws and burner hold-down bracket.
NOTE: If the heat exchanger is sooted badly, the burner hold-down bracket and spacer can become distorted from direct flame impingement and this usually necessitates replacement of these parts.
2. Lift burners from slotted spacer and slide from orifices. Clean with a wire brush.
3. Orifices usually do not need to be replaced. To clean, run either copper wire or wood through orifice. Do not enlarge hole. To remove orifice, use a socket wrench and remove the manifold. DO NOT overtighten when reinstalling.

Pilot Removal and Cleaning

1. Disconnect pilot tubing at pilot and sensor/igniter wire. Remove screws holding pilot bracket to burner tray.
2. Remove pilot and bracket, clean pilot of debris, small bugs, etc., with wire or small brush.
3. Replace pilot, pilot tubing, sensor ignition wires and check for leaks.

High Limit or Tankstat Removal

1. Turn off electrical power.
2. Remove front inspection panel.
3. Remove wires to high limit and loosen screws holding high limit to cabinet.
4. Remove wedge clip holding sensing bulb in control well.
5. Remove high limit and install a new one.
6. Check control operation before leaving job.

Heat Exchanger Removal

1. Shut water, gas and electricity off, close valves and relieve pressure, remove relief valve.
2. Remove side inspection panels.
3. Remove top holding screws.
4. Remove draft diverter, lift and remove top and flue collector on stack type models. Remove inspection panels.
5. Loosen bolts and disconnect flange nuts on in/out header, loosen union(s) at gas pipe, and slide heater away from piping until studs clear the heater.
6. Remove heat exchanger corner brackets.
7. Remove combustion chamber clips at the four corners of the heat exchanger.

8. Lift heat exchanger straight up using caution not to damage refractory.

Heat Exchanger Re-Assembly

1. Heat exchanger water header O-rings must be replaced with new ones.
2. Install in/out and return water headers and install header retainer nuts and torque nuts evenly.
3. Install the four (4) corner clips between tube sheets and refractory. Replace "V" baffles.
4. Install thermostat sensing bulbs in header wells and replace bulb retaining clips.
5. Install inlet and return pipes in water headers using pipe thread sealant.
6. Install water pressure relief valve, flow switch, and low water cut-off devices (if so equipped).
7. Open water supply and return shut-off valves. Fill heater and water piping system with water. Check heater and piping system for leaks at full line pressure. Run system circulating pump for a minimum of 1/2 hour with heater shut-off.
8. Shut down entire system and vent all radiation units and high points in system piping. Check all strainers for debris. Expansion tank water level should be at the 1/4 mark and the balance of the tank filled with air.
9. Install flue collector, jacket top and inspection panels. Install top holding screws. Install draft diverter and vent piping if so equipped.
10. If gas piping was disconnected, reconnect gas piping system and check for leakage using a soap solution.
11. Check for correct water pressure and water level in the system. Make sure that system pump operates immediately on the call for heat. The system is ready for operation.
12. Within two (2) days of start-up, recheck all air vents and expansion tank levels.

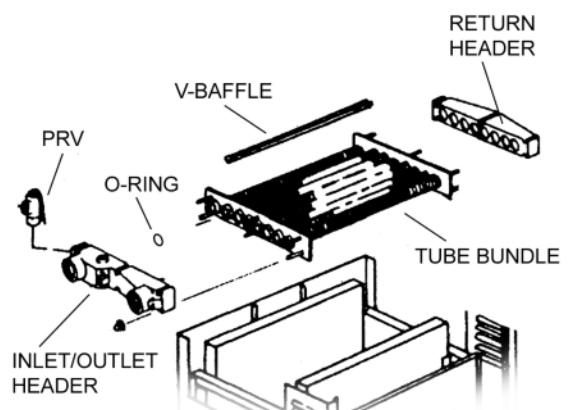

Fig. 40: Typical Heat Exchanger Configuration

Combustion Chamber Removal Tube Replacement

To remove combustion chamber refractory you must first have removed the heat exchanger. Unbolt metal combustion chamber retainer from top and remove refractory panels individually.



Fig. 41: Refractory Panels—Top View

WARNING: This unit contains refractory ceramic fiber (RCF) insulation in the combustion chamber. RCF, as manufactured, does not contain respirable crystalline silica. However, following sustained exposure to very high temperatures (>2192°F), the RCF can transform into crystalline silica (cristabolite). The International Agency for Research on Cancer (IARC) has classified the inhalation of crystalline silica (cristabolite) as carcinogenic to humans.

When removing the burners or heat exchangers, take precautions to avoid creating airborne dust and avoid inhaling airborne fibers. When cleaning spills, use wet sweeping or High Efficiency Particulate Air (HEPA) filtered vacuum to minimize airborne dust. Use feasible engineering controls such as local exhaust ventilation or dust collecting systems to minimize airborne dust. Wear appropriate personal protective equipment including gloves, safety glasses with side shields, and appropriate NIOSH certified respiratory protection, to avoid inhalation of airborne dust and airborne fiber particles.

1. Remove heat exchanger from heater following instructions outlined under HEAT EXCHANGER REMOVAL on page 45.
2. Remove in/out and return headers. Remove "V" baffle from damaged tube.
3. Remove damaged tube by cutting with a hack saw or shearing with a chisel adjacent to each tube sheet.
4. Collapse stub ends in tube sheets using a chisel or screwdriver. DO NOT cut into tube sheet or mar surface in tube hole in any way.
5. Insert replacement tube by inserting the end with the most fins removed in the opening of one tube sheet. Slide tube until the opposite end clears the other tube sheet and fit the tube into the hole.
6. Insert the tube roller into tube opening up to stop, making certain that 1/8" of tube projects beyond the tube sheet.
7. Attach drill to tube roller, holding it straight and level. Note: Use a 3/8" heavy duty, reversible, electric drill or larger. Proceed to expand tube until tool starts to grab. Approximately 1/2 to 1" of the tool shank will be visible.
8. Reverse drill motor and withdraw tube roller, if necessary wrench out by hand.
9. DO NOT apply excessive torque during rolling operation and avoid thinning any wall of the tube beyond 0.015".
10. Use same procedure on opposite end.
11. Apply line pressure test. Re-roll if necessary.
12. Reinstall as outlined under HEAT EXCHANGER REASSEMBLY.

Control Well Replacement

Remove top, sensing bulb and clip. Collapse well tube at the open end and with a chisel, push through into header and remove the well through header. Insert a new well and roll into place. If a roller is not available, solder the well in place with silver solder.

Cleaning Flue Gas Passageways

Soot will clog areas between fins and cause eventual tube failure. Any sign of soot at base of burners or around outer jacket indicates a need for cleaning.

1. Lift off draft hood and flue collector by removing bolts and screws.
2. Remove "V" baffles from heat exchanger.
3. Remove burner tray.
4. Take garden hose and wash heat exchanger, making sure soot is removed from between fins. (Avoid excessive water against refractory).
5. Reassemble: When heater is fired, some steam will form from wet refractory. This is normal.
6. Identify and correct reason for soot formation.

NOTE: In extreme cases it may be necessary to remove the heat exchanger completely for cleaning. The simplest method is high pressure cleaning at a local car wash. **DO NOT WIRE BRUSH!**

CAUTION: Soot is combustible, so exercise extreme care.

REPLACEMENT PARTS

See separate parts sheet in instruction envelope.

NOTE: To supply the correct part it is important that you state the model number, serial number and type of gas when applicable.

Any part returned for replacement under standard company warranties must be properly tagged with RAYPAK return parts tag, completely filled in with the heater serial number, model number, etc., and shipped to the Company freight prepaid. If determined defective by the Company and within warranty, the part will be returned in kind or equal substitution, freight collect. Credit will not be issued.

RAYPAK, INC.
2151 Eastman Avenue
Oxnard, CA 93030



**LIMITED PARTS WARRANTY
RAYTHERM™ COMMERCIAL HEATERS
TYPES H & WH
MODELS 0133 TO 4001**

SCOPE:

Raypak, Inc. ("Raypak") warrants to the original owner that all parts of this heater which are actually manufactured by Raypak will be free from failure under normal use and service for the specified warranty periods and subject to the conditions set forth in this Warranty. Labor charges and other costs for parts removal or reinstallation, shipping and transportation are not covered by this Warranty but are the owner's responsibility.

ANY PART MANUFACTURED BY RAYPAK:

One (1) year warranty from date of heater installation, or eighteen (18) months from date of factory shipment based on Raypak's records, whichever comes first.
SATISFACTORY PROOF OF INSTALLATION DATE, SUCH AS INSTALLER INVOICE, IS REQUIRED. THIS WARRANTY WILL BE VOID IF THE HEATER RATING PLATE IS ALTERED OR REMOVED.

HEAT EXCHANGER WARRANTY:

Domestic Hot Water

Five (5) years from date of heater installation. Includes copper heat exchanger with bronze and cast iron waterways.
Ten (10) years from date of heater installation. Includes only cupro-nickel heat exchanger with bronze or cast iron waterways.

Space Heating (Closed Loop System)

Ten (10) years from date of heater installation. Includes both cupro-nickel and copper heat exchanger with bronze or cast iron waterways.

Thermal Shock Warranty

Twenty (20) years from date of heater installation against "Thermal Shock" (excluded, however, if caused by heater operation at large changes exceeding 150°F between the water temperature at intake and heater outlet temperature, or operating at heater temperatures exceeding 230°F).

ADDITIONAL WARRANTY EXCLUSIONS:

This warranty does not cover failures or malfunctions resulting from:

1. Failure to properly install, operate or maintain the heater in accordance with our printed instructions provided;
2. Abuse, alteration, accident, fire, flood and the like;
3. Sediment or lime build-up, freezing, or other conditions causing inadequate water circulation;
4. High velocity flow exceeding heater design rates;
5. Failure of connected systems devices, such as pump or controller;
6. Use of non-factory authorized accessories or other components in conjunction with the heater system;
7. Failure to eliminate air from, or replenish water in, the connected water system;
8. Chemical contamination of combustion air or use of chemical additives to water.

PARTS REPLACEMENT:

Under this Warranty, Raypak will furnish a replacement for any failed part. The failed part must first be returned to Raypak if requested, with transportation charges prepaid, and all applicable warranty conditions satisfied. The replacement part will be warranted for only the unexpired portion of the original warranty. Raypak makes no warranty whatsoever on parts manufactured by others, but Raypak will apply any such warranty as may be provided by the parts manufacturers.

TO MAKE WARRANTY CLAIM:

Promptly notify the original installer, supplying the model and serial numbers of the unit, date of installation and description of the problem. The installer must then notify a Raypak distributor for instructions regarding the claim. If either is not available, contact Service Manager, Raypak, Inc., 2151 Eastman Avenue, Oxnard, CA or call (805) 278-5300. In all cases proper authorization must first be received from Raypak before replacement of any part.

EXCLUSIVE WARRANTY - LIMITATION OF LIABILITY:

This is the only warranty given by Raypak. No one is authorized to make any other warranties on Raypak's behalf. THIS WARRANTY IN LIEU OF ALL OTHER WARRANTIES, EXPRESS OR IMPLIED, INCLUDING BUT NOT LIMITED TO IMPLIED WARRANTIES OF MERCHANTABILITY AND FITNESS FOR A PARTICULAR PURPOSE. RAYPAK'S SOLE LIABILITY AND THE SOLE REMEDY AGAINST RAYPAK WITH RESPECT TO DEFECTIVE PARTS SHALL BE AS PROVIDED IN THIS WARRANTY. IT IS AGREED THAT RAYPAK SHALL HAVE NO LIABILITY, WHETHER UNDER THIS WARRANTY, OR IN CONTRACT, TORT, NEGLIGENCE OR OTHERWISE, FOR ANY SPECIAL, CONSEQUENTIAL, OR INCIDENTAL DAMAGE, INCLUDING DAMAGE FROM WATER LEAKAGE. Some states do not allow limitations on how long an implied warranty lasts, or for the exclusion of incidental or consequential damages. So the above limitation or exclusion may not apply to you.

This Limited Warranty gives you specific legal rights. You may also have other rights which may vary from state to state. We suggest that you complete the information below and retain this certificate in the event warranty service is needed. Reasonable proof of the effective date of the warranty (date of installation) must be presented, otherwise, the effective date will be based on the date of manufacture plus thirty (30) days.

Name of Owner

Name of Dealer

Address

Address

Model No.

Serial No.

Date of Installation:

Date of Initial Operation:

RAYPAK, INC. • 2151 Eastman Avenue • Oxnard, CA 93030 • (805) 278-5300 • Fax (800) 872-9725 • www.raypak.com

START-UP CHECKLIST FOR RAYPAK PRODUCTS ATMOSPHERIC

This start-up checklist is to be completely filled out by the service technician starting up the Raypak Boiler or heater for the first time. All information will be used for warranty purposes and to insure that the installation is correct. Additionally this form will be used to record all equipment operation functions and required settings.

GAS SUPPLY DATA

Gas Meter Size _____ CFH
 Gas Line Size _____ In. NPT
 Length of Gas Line _____
 Low Gas Pressure Setting _____ In. WC
 High Gas Pressure Setting _____ In. WC
 Gas Valve Type _____

CLEARANCES

Front Clearance _____ In.
 Right Side Clearance _____ In.
 Left Side Clearance _____ In.
 Rear Clearance _____ In.
 Overhead Clearance _____ In.

ELECTRICAL

Voltage Supply/Control _____
 Auto High Limit Setting _____
 Manual Reset High Limit _____
 Ignition Control: S8600 _____ Other _____
 Is unit grounded ___ Yes ___ No
 Temp Control Setting _____ Deg

VISUAL INSPECTION OF COMPONENTS

Wiring Harness _____
 Pilot Assembly _____
 Burner/s _____
 Refractory _____
 Remote (if applicable) _____

WATER SUPPLY

Flow Rate in GPM or Delta T _____ If Avail
 Pump Economaster setting _____ Min
 Low Water Cutoff _____ Test
 Number of Tanks and Size _____
 Pressure Switch _____
 Plumbing Size _____ Inches
 Pump Size: _____ Pump HP: _____

VENTING

Vent Size: _____ Stack Height: _____
 Vent Category: _____
 Vent Material: _____
 Vent Termination Type: _____
 Combustion Air Openings: _____ Sq. In.

Model Number: _____ Serial Number: _____

Job Name _____

Address _____

Physical Location of Boiler: Indoors ___; Outdoors ___; Ground Level ___; Roof ___; Below Grade ___

Mechanical Contractor/Installer _____

Date and Time of Start-up _____ Print Name _____

Signature of Startup Technician _____



www.raypak.com

Raypak, Inc., 2151 Eastman Avenue, Oxnard, CA 93030 (805) 278-5300 Fax (805) 278-5468
Litho in U.S.A.