



The new degree of comfort.™



Commercial Gas
Xtreme Water Heaters

Xtreme™ is a family of high-input, fast recovery commercial water heaters that complies with Low NOx Emissions

Features & Benefits

Xtreme is an advanced line of fast recovery commercial gas water heaters. These products can deliver up to 756 gallons per hour at 100 degree F rise. The small jacket diameter makes it a popular choice for retro fits and it is a versatile choice for new construction. Models range from 500,000-715,000 Btu/h, with a maximum temperature setting of 180 degrees Fahrenheit.

Space Saver Design

Xtreme maximizes installation adaptability by offering models with front and rear inlet/outlet water connections. Short heights and small jacket diameters result in greater installation flexibility.

System Sentinel™ LED Diagnostic System

Our exclusive diagnostic system, with glowing LED lights, verifies system operation sequence by sequence.



Patented Multi-Flue Tank Design

Proprietary steel formulation, patented multi-flue design, and two coats of high temperature porcelain enamel maximize corrosion resistance and result in a superior heat exchanger design.

Automatic Flue Damper

Low profile design minimizes overall product height. Heavy duty vent hood supports are designed to withstand rigors of installation.

Specialized Burner Assembly

Each model features five premix burners mounted into a metal face plate and sealed with a Viton gasket. Patented "quick release" manifold for easier service.

Direct Spark-to-Pilot Ignition System

Energy saving ignition that ignites pilot only when there is a call for heat.

Round Premix Burners

Precision burners are formed from high chromium stainless steel.

Low NOx Emissions

GX90-550 and GX90-640 meet low NOx emissions of less than 40 ng/J.

Full-port, Full-flow Drain Valve

Factory installed brass drain valve allows for faster draining and servicing.

Altitude Certifications

Standard Natural and LP models are certified up to 2,000 feet. High altitude models, 8,000 feet.

Anode Rods

Patented design utilizes multiple magnesium rods to ensure long life and corrosion resistance.

Warranty

3-Year limited tank warranty
See Commercial Warranty Certificate for complete information.

Efficiency | All models have been tested according to ANSI test procedures, and exceed the thermal efficiency and standby loss requirements of current ASHRAE standards (Part of the Federally mandated Energy Policy Act (EPAct)). Also exceeds energy efficiency codes of all states.

Safety and Construction | These products are design certified by U.L.: a) For operation at 180°F. b) To meet all safety and construction requirements of ANSI Z21.10.3-2001 c) As an automatic storage or instantaneous water heater. d) As an automatic circulating tank water heater. e) For operation on combustible floors and in alcove installations.

Certified for 150 PSI maximum working pressure (160 PSI for ASME models).

Continued next page



Rheem Xtreme
90-Gallon Capacity
500,000-715,000 Btu/h
Low NOx
Natural and LP Gas



(On Selected Models)



INTEGRATED AIR & WATER

CSA/ASME Rated T&P Valve

Factory installed relief valve

Insulation

Sag and moisture proof fiberglass insulation surrounds the storage tank to minimize heat loss.

Hand-Hole Cleanout

It's perfect for removal of lime/sediment deposits.

Manual Reset High Limit

All models are factory equipped with a manual reset high limit to meet the code requirements of many states.

Gas Control System

The fully adjustable thermostat ranges from 100°F to 180°F and 24 volt combination gas valve includes main gas pressure regulation, On-Off manual valve, 120/24 volt transformer, and high limit temperature cut-out.

RECOVERY CAPACITIES Recovery in U.S. Gallons/Hr. (GPH) and Liters/Hr. (LPH) at Various Temperature Rises.														
MODEL NUMBER	INPUT BTU/H NATURAL & L.P.	THERMAL EFFICIENCY	UNITS	40°F	50°F	60°F	70°F	80°F	90°F	100°F	110°F	120°F	130°F	140°F
				22°C	28°C	33°C	39°C	45°C	50°C	56°C	61°C	67°C	72°C	78°C
GX90-550(A)	550,000 NAT	80%	GPH	1333	1067	889	762	667	593	533	485	444	410	381
			LPH	5047	4037	3364	2884	2523	2243	2019	1835	1682	1553	1442
GX90-640(A)	640,000 NAT	80%	GPH	1551	1241	1034	887	776	690	621	564	517	477	443
			LPH	5873	4698	3915	3356	2936	2610	2349	2135	1958	1807	1678
GX90-715(A)	715,000 NAT	80%	GPH	1733	1387	1156	991	867	770	693	630	578	533	495
			LPH	6561	5249	4374	3749	3280	2916	2624	2386	2187	2019	1875
GX90-500(A)	500,000 LP	80%	GPH	1212	970	808	693	606	539	485	441	404	373	346
			LPH	4588	3670	3059	2622	2294	2039	1835	1668	1529	1412	1311
GX90-600(A)	600,000 LP	80%	GPH	1455	1164	970	831	727	647	582	529	485	448	416
			LPH	5506	4404	3670	3146	2753	2447	2202	2002	1835	1694	1573
GX90-680(A)	680,000 LP	80%	GPH	1649	1319	1099	942	824	733	659	599	550	507	471
			LPH	6240	4992	4160	3565	3120	2773	2496	2269	2080	1920	1783

Recovery ratings are based on thermal efficiencies obtained in a CSA certified laboratory. Recovery rate shown on the rating plate (80%) Thermal Efficiency in accordance with ANSI Z21.10.3 labeling requirements. (A) indicates available ASME model.

MAXIMUM DELIVERY In U.S. Gallons and Liters. (Includes useable storage and recovery for indicated times.)															
MODEL NUMBER	TANK CAPACITY		INPUT BTU/H NAT. & L.P.	TEMP. RISE	UNITS	5	10	15	20	30	45	60	120	180	Min. to Rec. Contents
	GALLONS	LITERS				Min.	Min.	Min.	Min.	Min.	Min.	Min.	Min.		
GX90-550(A)	90	341	550,000 NAT	100°F	GAL.	107	152	196	241	330	463	596	1130	1663	10
				55.6°C	LTR.	407	575	743	911	1248	1752	2257	4276	6294	
GX90-640(A)	90	341	640,000 NAT	100°F	GAL.	115	166	218	270	373	529	684	1304	1925	9
				55.6°C	LTR.	434	630	826	1022	1413	2000	2587	4936	7285	
GX90-715(A)	90	341	715,000 NAT	100°F	GAL.	121	179	236	294	410	583	756	1450	2143	8
				55.6°C	LTR.	457	676	894	1113	1551	2207	2863	5487	8111	
GX90-500(A)	90	341	500,000 LP	100°F	GAL.	103	144	184	225	305	427	548	1033	1518	11
				55.6°C	LTR.	391	544	697	850	1156	1615	2073	3909	5744	
GX90-600(A)	90	341	600,000 LP	100°F	GAL.	112	160	209	257	354	499	645	1227	1809	9
				55.6°C	LTR.	422	606	789	972	1340	1890	2441	4643	6845	
GX90-680(A)	90	341	680,000 LP	100°F	GAL.	118	173	228	283	393	558	722	1382	2041	8
				55.6°C	LTR.	446	654	862	1070	1486	2110	2886	5230	7726	

DIMENSIONAL INFORMATION All Dimensions Shown in English and Metric.												
MODEL NUMBER	UNITS	A	B	C	D	E	F	G	WATER CONNECTIONS		APPROXIMATE SHIPPING WEIGHT	
									FRONT SIDE	REAR SIDE	STD.	ASME
GX90-550(A)	inches	74.5	68	30	25	10	59	1	2	2	905	945
	mm	1892	1727	768	635	254	1509	25.4	51	51	905	945
GX90-640(A)	inches	74.5	68	30	25	10	59	1	2	2	905	945
	mm	1892	1727	768	635	254	1509	25.4	51	51	905	945
GX90-715(A)	inches	74.5	68	30	25	10	59	1	2	2	905	945
	mm	1892	1727	768	635	254	1509	25.4	51	51	905	945
GX90-500(A)	inches	74.5	68	30	25	10	59	1	2	2	905	945
	mm	1892	1727	768	635	254	1509	25.4	51	51	905	945
GX90-600(A)	inches	74.5	68	30	25	10	59	1	2	2	905	945
	mm	1892	1727	768	635	254	1509	25.4	51	51	905	945
GX90-680(A)	inches	74.5	68	30	25	10	59	1	2	2	905	945
	mm	1892	1727	768	635	254	1509	25.4	51	51	905	945

All models require a 120V power source. (A) Suffix indicates ASME tank construction available.

CLEARANCES TO COMBUSTIBLES				
MODEL NUMBER	UNITS	SIDE	REAR	TOP
GX90-550	inches	4	4	12
	mm	102	102	305
GX90-640	inches	4	4	12
	mm	102	102	305
GX90-715	inches	4	4	12
	mm	102	102	305
GX90-500	inches	4	4	12
	mm	102	102	305
GX90-600	inches	4	4	12
	mm	102	102	305
GX90-680	inches	4	4	12
	mm	102	102	305

Allow a minimum of 18" (457mm) front clearance for servicing.
2.5 Amps.

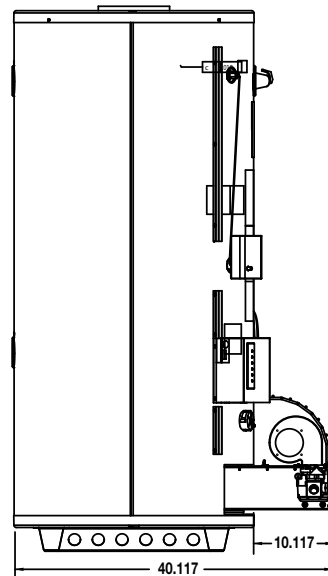
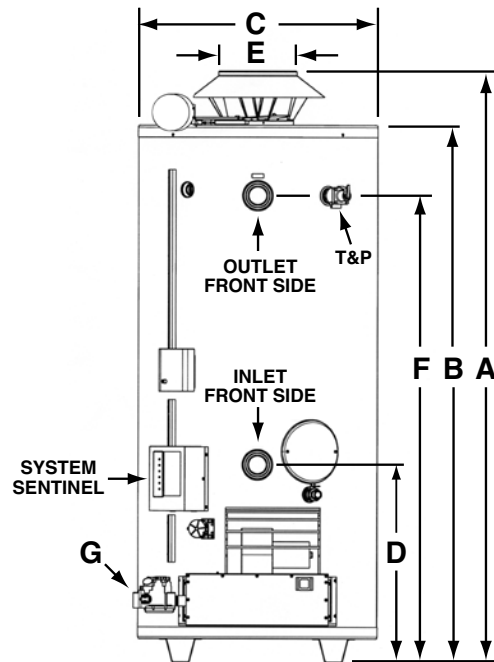



The new degree of comfort.™



Recommended Specifications (for trade reference only)

Water heater(s) shall be Xtreme model _____, manufactured by Rheem, having gas input of _____ Btu/h and a recovery rate of _____ GPH at a 100°F temperature rise when tested and certified at _____ thermal efficiency. Water heater(s) shall have a storage capacity of 90 gallons. Water heater(s) shall have the U.L. seal of certification and supplied with a factory installed CSA/ASME rated temperature and pressure relief valve. Tank(s) shall be furnished with a tube bundle having a double coating of high temperature porcelain enamel and furnished with magnesium anode rods rigidly supported. Water heater(s) shall meet or exceed the thermal efficiency and standby loss requirements of current ASHRAE standards. Tanks shall have

a working pressure rating of 150 psi, and shall be completely factory assembled, including a pressure regulator properly adjusted for operation on _____ gas with chromium stainless steel burners. Controls will be arranged for safety shutoff in event of pilot failure. Water heater(s) shall have front and rear side inlet/outlet water connections. Water heater(s) shall be covered by a three year limited warranty against tank leaks.

When ordering ASME construction, place (A) after the model number (for trade reference only)

Water heater(s) shall be constructed in accordance with the requirements of the ASME Boiler and Pressure Vessel Code, Section IV Part HLW.

In keeping with its policy of continuous progress and product improvement, Rheem reserves the right to make changes without notice.

Rheem Water Heating • 101 Bell Road
Montgomery, Alabama 36117-4305 • www.rheem.com

Rheem Canada Ltd./Ltée • 125 Edgeware Road, Unit 1
Brampton, Ontario L6Y 0P5 • www.rheem.com

