

Cold Water Solutions

For Raytherm® and Hi Delta® Boilers

**Prevent condensation
Protect Your Boiler Investment**

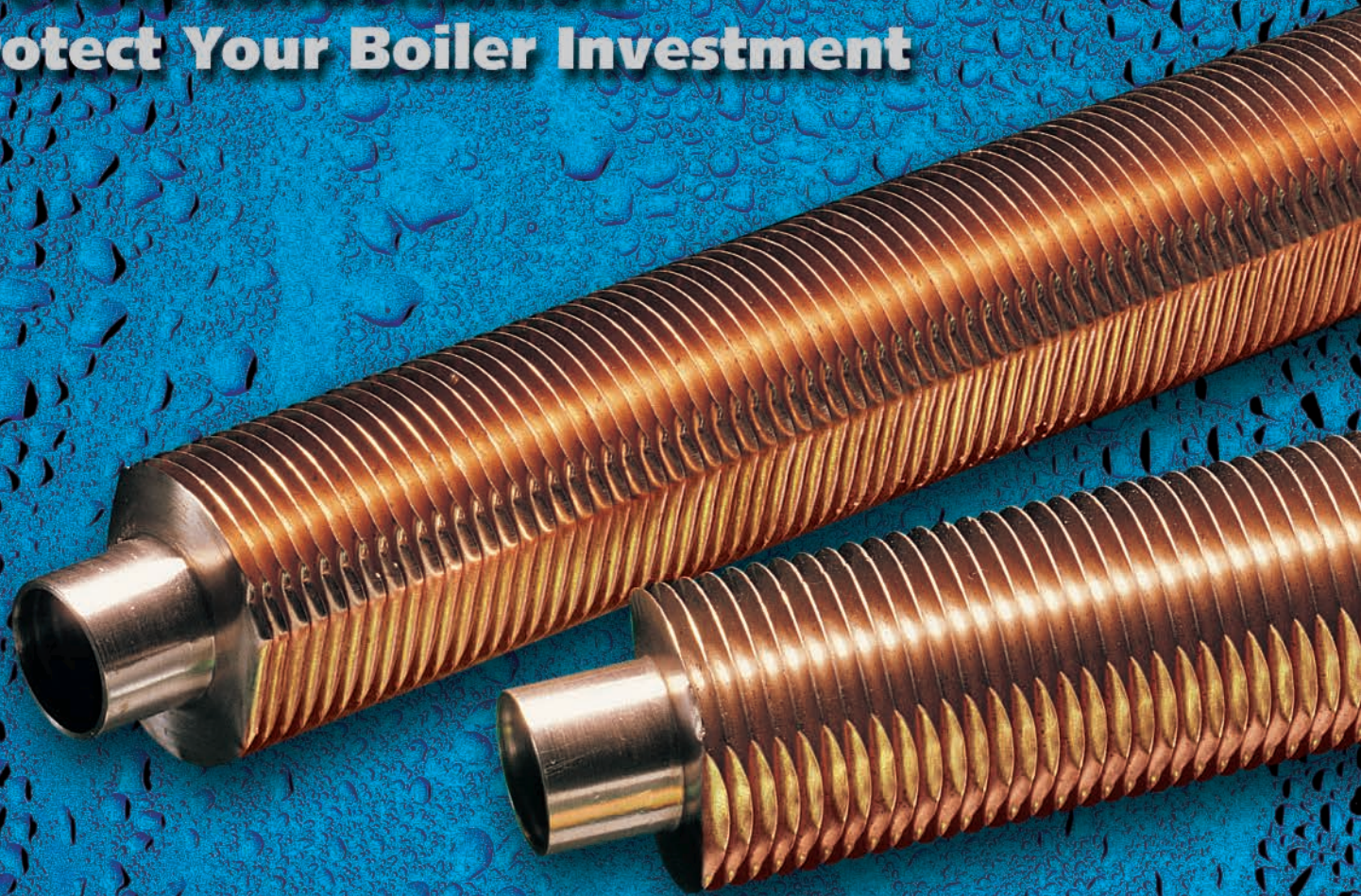

Raypak

COLD WATER START

It is commonly known that prolonged internal condensation will dramatically shorten the life of standard boilers and water heaters. While Raypak boilers and water heaters can operate without harmful condensation at lower inlet water temperatures than the competition, there are still applications that require reliable protection against harmful condensation caused by frequent, extended, cold water start-ups. Raypak's **Cold Water Start** protection system utilizes a proportional three-way valve to bypass water from the boiler outlet to the inlet during start-up, when the system return water temperature is below the minimum acceptable level.

Boiler Start-Up Cycle

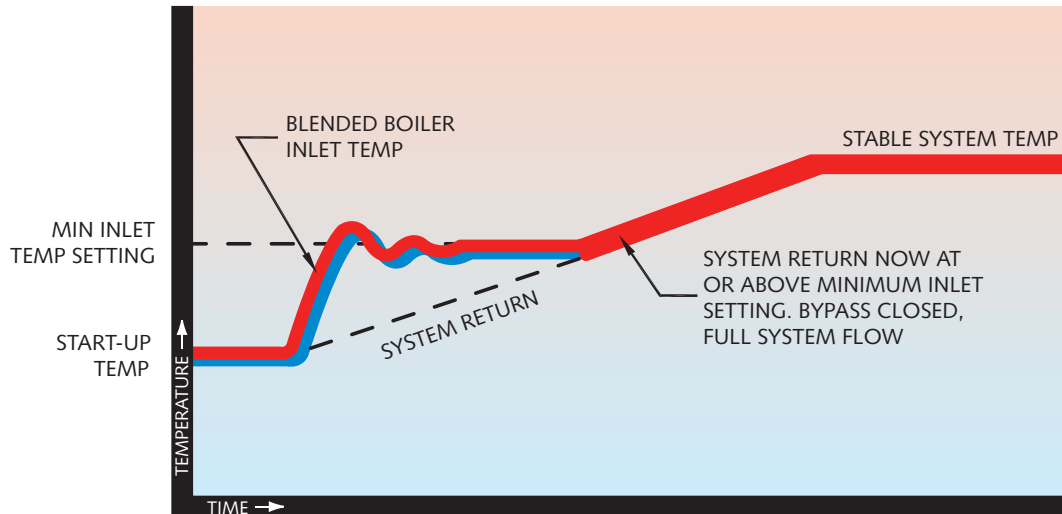

Raypak's Cold Water Start system:

- Continuously monitors and adjusts inlet water temperature to prevent condensation
- Regulates minimum inlet water temperature during system start-up
- Activates alarm and/or shuts down boiler if the minimum inlet water temperature is not achieved
- Eliminates job site set-up with proprietary self-tuning controller and system-matched components
- Utilizes proportional three-way valve to achieve bypass
- Allows high-temperature system operation without cycling on high-limit

APPLICATIONS

Commercial Hydronic Heating

- Office Buildings
- Factories/Warehouses
- Greenhouses

Domestic Hot Water Supply

- Restaurants
- Weekend Shut-down (e.g. 6-day/week shopping center)
- Dump Loads
- Intermittent Industrial Process



COLD WATER RUN

For the same reason stated for Cold Water Starts, it is even more important to provide protection against condensation from cold inlet water on systems where the return water temperature to the boiler will always be below the acceptable minimum. Raypak's **Cold Water Run** system utilizes a variable-speed pump to inject just the right amount of water from the main system loop into the boiler to maintain the optimum inlet temperature. This approach allows the full capacity of the boiler to be utilized to meet the system load, while at the same time continuously maintaining the optimum inlet water temperature to prevent condensation.

Boiler Start-Up Cycle

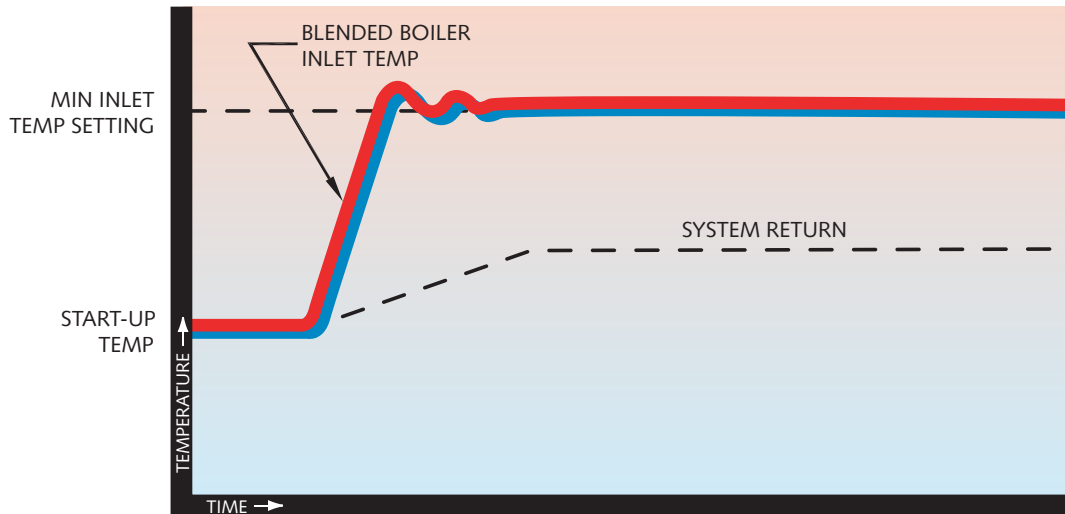

Raypak's Cold Water Run system:

- Continuously monitors and adjusts inlet water temperature to prevent condensation
- Regulates minimum inlet water temperature regardless of system temperature
- Activates alarm and/or shuts down boiler if the minimum inlet water temperature is not achieved
- Protects boiler from constant low return water temperatures with its proprietary self-tuning controller
- Utilizes variable-speed injector pump to control boiler loop temperature



APPLICATIONS

- Pool Heating
- Low-temperature Industrial Process
- Very Low-temperature Return Water (e.g. convalescent hospital domestic hot water)

COLD WATER START

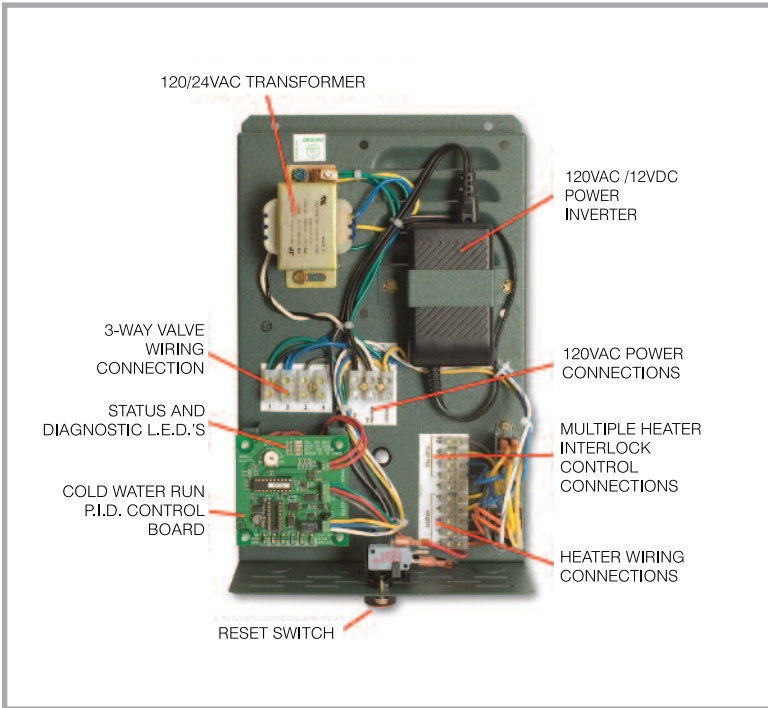

Cold Water Start J-Box Assembly

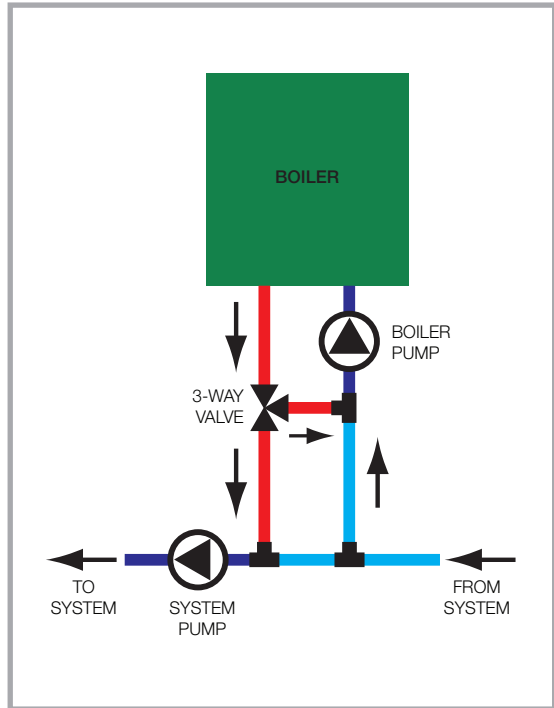

Typical Cold Start Plumbing
Pictorial-Not to Scale

COLD WATER RUN

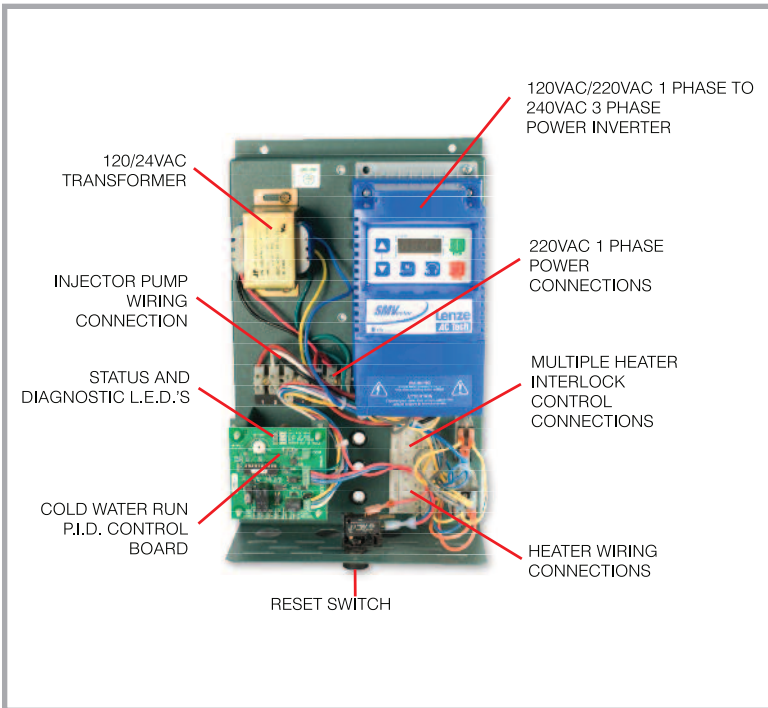

Cold Water Run J-Box Assembly

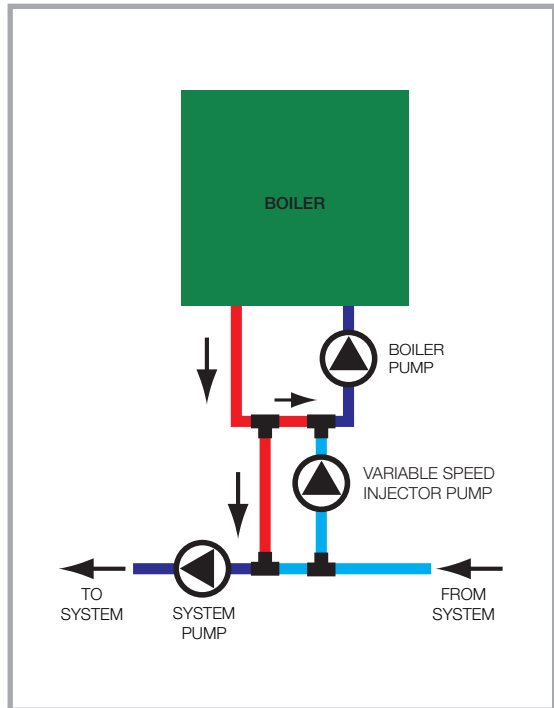

Typical Cold Run Plumbing
Pictorial-Not to Scale

TECHNICAL DATA

COLD WATER START

TYPICAL BOILER PIPING*

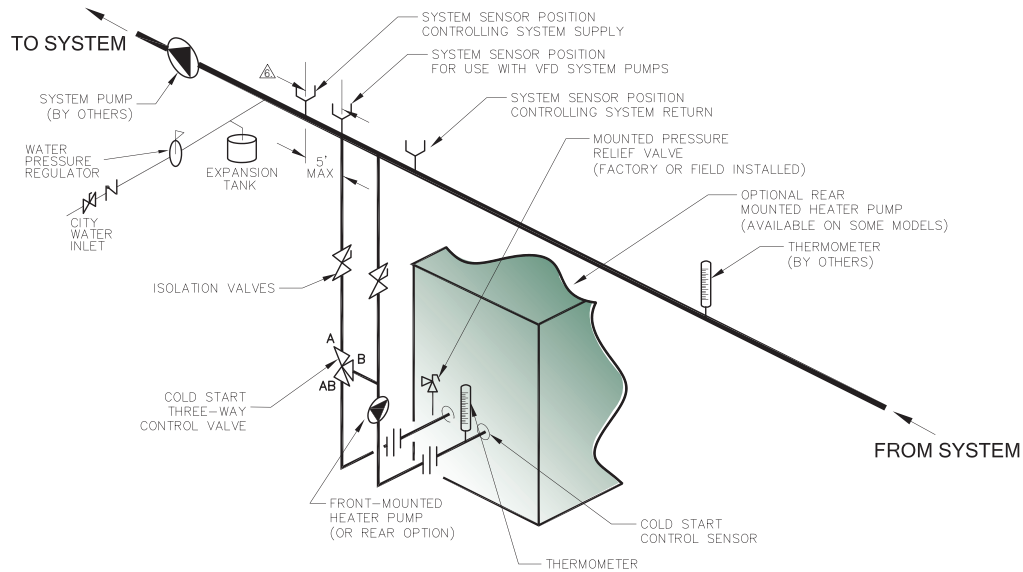

NOTES:

1. LOCATE UNIONS TO FACILITATE SERVICING OF PLUMBING SIDE.
 2. PLUMB SWING CHECK VALVE IN GRAVITY-CLOSED POSITION.
 3. PIPE ALL RELIEF VALVES TO DRAIN, OR AS LOCAL CODES REQUIRE.
 4. BUFFER TANK REQUIRED WHEN WATER VOLUME IN BOILER LOOP IS NOT ADEQUATE TO PROVIDE STABLE TEMPERATURE CONTROL. CONSULT FACTORY FOR TANK SIZING.
 5. SYSTEM FLOW MUST BE AT LEAST 120% OF HEATER FLOW AT ALL TIMES.
- ⚠️ 4 PIPE DIAMETERS MAX, NOT TO EXCEED 12"

* ITEMS REQUIRED FOR COLD WATER START ARE SHOWN. OTHER STANDARD SYSTEM COMPONENTS HAVE BEEN OMITTED FOR CLARITY.

COLD WATER RUN

TYPICAL BOILER PIPING*

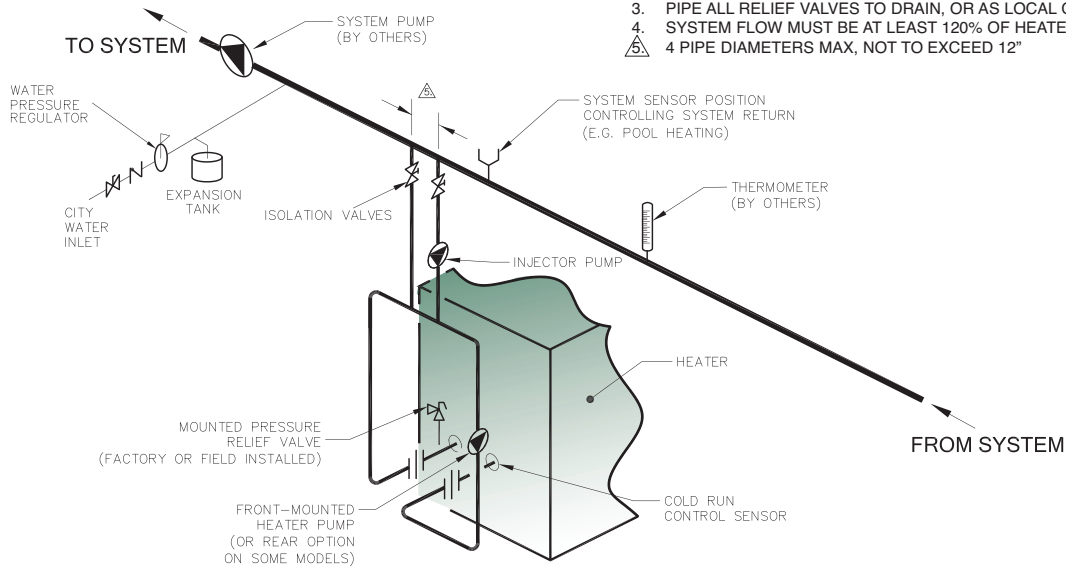

NOTES:

1. LOCATE UNIONS TO FACILITATE SERVICING OF PLUMBING SIDE.
 2. PLUMB SWING CHECK VALVE IN GRAVITY-CLOSED POSITION.
 3. PIPE ALL RELIEF VALVES TO DRAIN, OR AS LOCAL CODES REQUIRE.
 4. SYSTEM FLOW MUST BE AT LEAST 120% OF HEATER FLOW AT ALL TIMES.
- ⚠️ 4 PIPE DIAMETERS MAX, NOT TO EXCEED 12"

* ITEMS REQUIRED FOR COLD WATER RUN OPERATION ARE SHOWN. OTHER STANDARD SYSTEM COMPONENTS HAVE BEEN OMITTED FOR CLARITY.

TECHNICAL DATA

MULTIPLE UNIT COLD WATER START

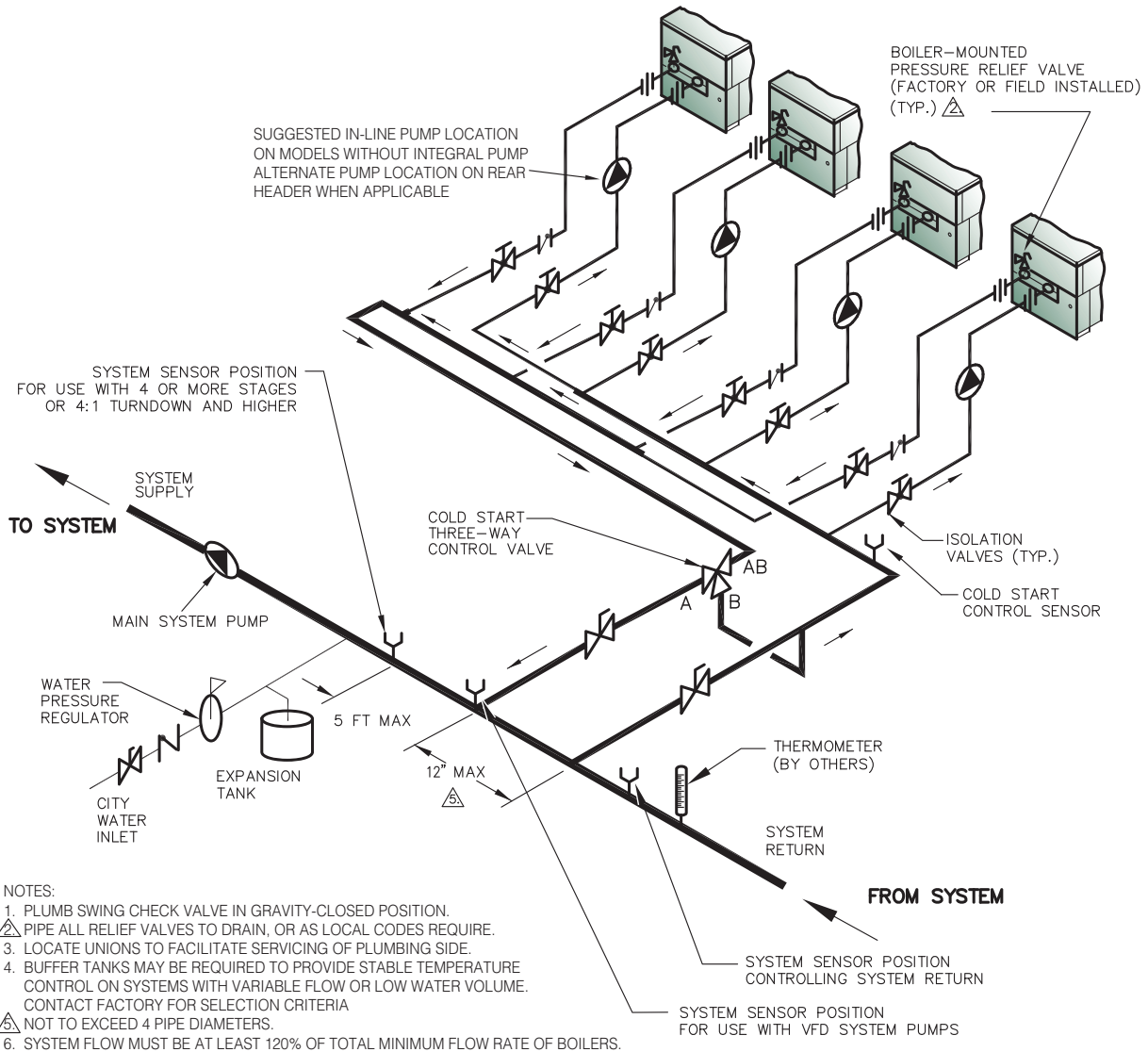

Total System Load (MBTUH)	Three-Way Diverting Valve Specifications			
	Valve Size	Cv	GPM	ΔP
500-900	2 NPT	57	70	3.5'
901-1,800	2-1/2 NPT	74	100	4.2'
1,801-3,000	2-1/2 NPT	100	150	5.2'
3,001-4,000	4" Flange	152	220	4.8'
4,001-6,000	4" Flange	254	330	3.9'
6,001-8,000	4" Flange	327	440	4.2'

Notes:

1. Maximum of 4 boilers per system.
2. Many variables can impact the proper valve sizing for multiple boilers. This sizing is provided as a guide. When in doubt consult the factory.
3. Multi-unit system ALWAYS shipped loose- Not available mounted.
4. 4" flanges, bolts and gaskets supplied by others. Multi-units with 4" valves are to be used on hydronic heating only. The valve body is cast iron.