

# INSTALLATION & OPERATING INSTRUCTIONS

## Induced Draft Assembly

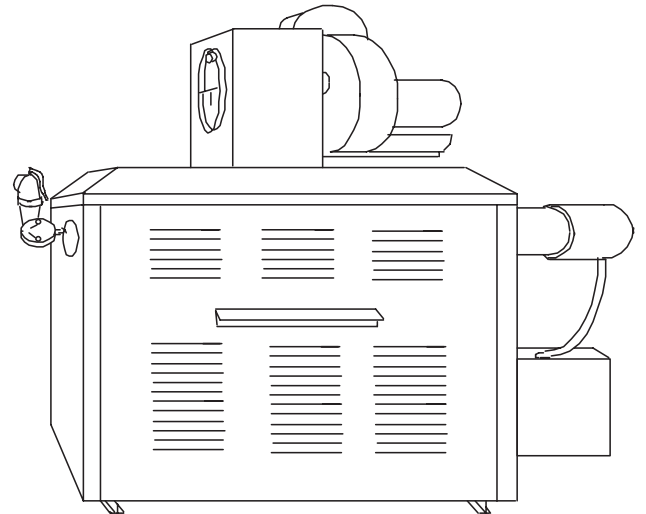

**For Raytherm™ Models  
0514-4001 – Type D**



**WARNING:** If these instructions are not followed exactly, a fire or explosion may result causing property damage, personal injury or death.

**FOR YOUR SAFETY:** Do not store or use gasoline or other flammable vapors and liquids or other combustible materials in the vicinity of this or any other appliance. To do so may result in an explosion or fire.

**WHAT TO DO IF YOU SMELL GAS:**

- Do not try to light any appliance.
- Do not touch any electrical switch; do not use any phone in your building.
- Immediately call your gas supplier from a neighbor's phone. Follow the gas supplier's instructions.
- If you cannot reach your gas supplier, call the fire department.

Installation and service must be performed by a qualified installer, service agency or the gas supplier.

This manual should be maintained in legible condition and kept adjacent to the heater or in another safe place for future reference.

**Raypak®**  
A Rheem® Company

**Rev. 9** reflects the following: **Changes to:** Paragraph one of the **General Specifications** section on page 5; Fig. 4 on page 8 and Fig. 10 on page 12.

---

# CONTENTS

<b>Warnings</b>	<b>4</b>
<b>Pay Attention to These Terms</b>	<b>4</b>
<b>Receiving Equipment</b>	<b>5</b>
<b>General Specifications</b>	<b>5</b>
<b>Installation</b>	<b>6</b>
Mounting the Assembly	6
<b>Venting</b>	<b>6</b>
<b>Electrical Wiring</b>	<b>8</b>
Wiring Diagram—Existing Heater	9
Wiring Diagram—Heater with Installed Power Vent	10
<b>Sequence of Operation</b>	<b>11</b>
<b>Start-up Procedures</b>	<b>11</b>
Typical S8600 Ignition System	11
<b>Controls</b>	<b>12</b>
Blower Motor Contactor & Purge Relay	12
<b>Draft-Proving Switch</b>	<b>12</b>
<b>Positions of Discharge</b>	<b>12</b>
Models 0514–1826 Only	12
<b>Dimensions</b>	<b>14</b>

---

## Warnings

### Pay Attention to These Terms

<b>DANGER:</b>	Indicates the presence of immediate hazards which will cause severe personal injury, death or substantial property damage if ignored.
<b>WARNING:</b>	Indicates the presence of hazards or unsafe practices which could cause severe personal injury, death or substantial property damage if ignored.
<b>CAUTION:</b>	Indicates the presence of hazards or unsafe practices which could cause minor personal injury or product or property damage if ignored.
<b>NOTE:</b>	Indicates special instructions on installation, operation, or maintenance which are important but not related to personal injury hazards.

**NOTE:** Minimum 18 AWG, 105°C, stranded wire must be used for all low voltage (less than 30 volts) external connections to the unit. Solid conductors should not be used because they can cause excessive tension on contact points. Install conduit as appropriate. All high voltage wires must be the same size (105°C, stranded wire) as the ones on the unit or larger.

---

## Receiving Equipment

On receipt of your equipment it is suggested that you visually check for external damage to the carton. If the carton is damaged, it is suggested that a note be made on the Bill of Lading when signing for equipment. Remove the complete assembly from the carton and if it is damaged report the damage to the carrier immediately.

Be sure that you receive the number of packages indicated on the Bill of Lading. Claims for shortages and damages must be filed with the carrier by consignee.

Purchased parts are subject to replacement only under the manufacturer's warranty. Debits for defective replacement parts will not be accepted and defective parts will be replaced in kind only per our standard warranties.

When ordering parts, you must specify Model and Serial Number of the heater. When ordering under warranty conditions, you must also specify date of installation.

Raypak recommends that this manual be reviewed thoroughly before installing the Type D Assembly. If there are any questions which this manual does not answer, please contact your local Raypak Representative.

## General Specifications

The Type D Assembly is certified by the Canadian Standard Association (CSA) and conforms to the American National Standard ANSI Z21.13/CSA 4.9 - latest edition for hot water boiler.

The Type D Assembly is a fan-assisted combustion system designed for application to Raytherm type H, WH, and P models 0514 through 4001. When installed as directed, the heater is capable of operating in applications such as through-the-wall venting and reduced horizontal and vertical vent pipe sizes in new and existing installations.

The Type D Assembly includes a blower with a 120 VAC/60 Hz 1 Ph motor, a plenum complete with a draft control device, a draft-proving switch and a motor

Model No.	MBTUH		Min. Conn. Dia. (in.)	Part No.
	Input	Output		
0514	512	419	7	065128
0624	627	514	7	065129
0724	726	595	7	065130
0824	825	677	8	065131
0962	962	789	8	065351
1125	1125	922	8	065352
1223	1223	1002	8	065353
1336	1336	1096	10	065354
1468	1467	1203	10	065355
1631	1630	1337	10	065356
1826	1826	1497	10	065357
2100	2100	1722	14	005627
2500	2499	2047	14	005627
3001	3000	2460	16	005629
3500	3500	2870	16	005630
4001	4000	3280	18	005631

Table A: Draft Assembly Application and Part Numbers

relay with post-purge capability. When provided for field mounting, the assembly is equipped with a wire harness.

## Installation

The equipment must be installed in accordance with local codes, or in the absence of local codes with the latest edition of the National Fuel Gas Code, ANSI Z223.1, the National Electrical Code, ANSI/NFPA 70. In Canada, Installations must conform to correct CAN/CSA B149 and to the latest Canadian Electrical CODE PART 1.

The equipment must be installed in accordance with local installation regulations. These must be carefully followed in all cases. Authorities having jurisdiction shall be consulted before installations are made.

## Mounting the Assembly

### All Models

1. The standard indoor jacket top and flue collector for the particular heater model are used.
2. Install the baffle assembly supplied in the flue outlet. The baffle must be installed with the mounting arms positioned at the sides of the opening parallel to the sides of the heater.
3. Mount the plenum assembly on the jacket top using the silicone sealant and screws provided. Use a #28 drill (.1405" dia.) to drill the eight (8)

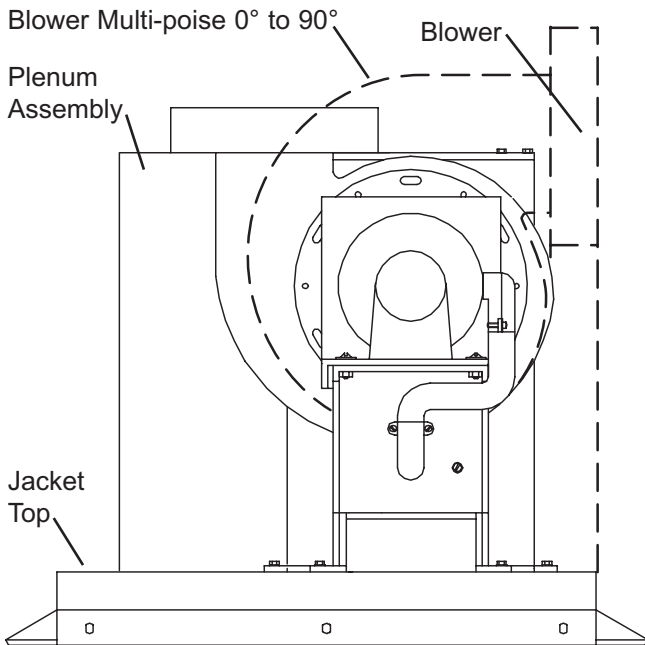

Fig. 1: Draft Assembly Mounting, Models 0514-1826

holes needed for the mounting screws. The assembly should be positioned to the rear of the heater.

4. Connect the wire harness to the heater junction box. Complete wiring in accordance with the enclosed wiring diagram.

### Models 2100-4001

The Type D Assembly for models 2100 through 4001 is installed directly on the top panel above the built-in draft hood. The adapter plate is anchored to the top using the silicone sealant and screws provided. Refer to Fig. 2.

## Venting

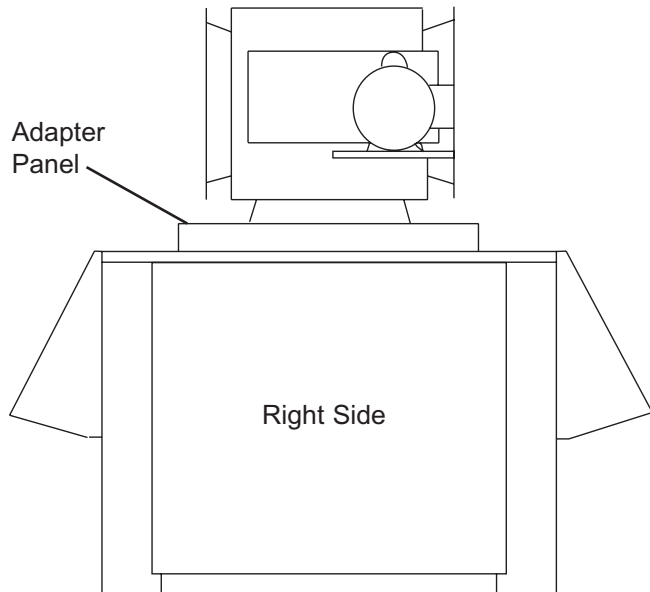
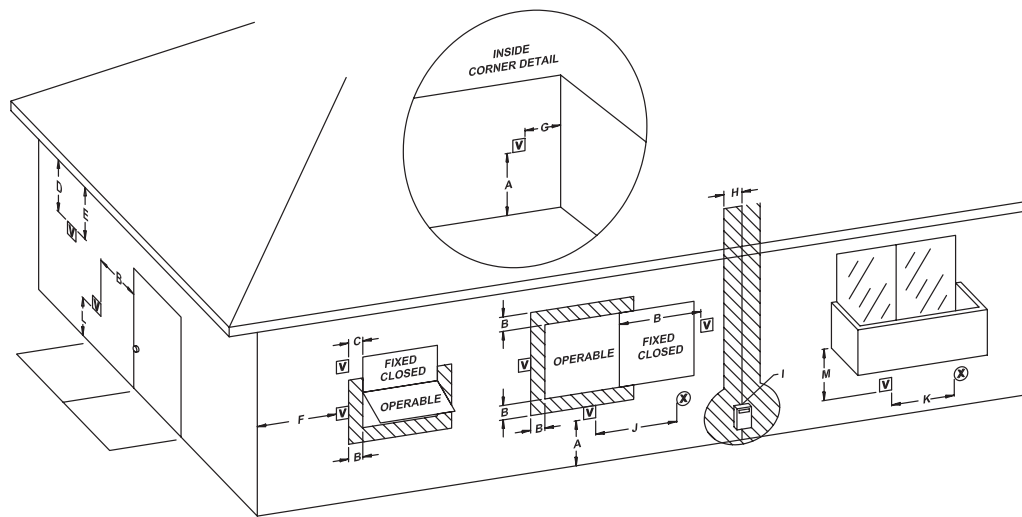

Fig. 2: Draft Assembly Mounting, Models 2100-4001

The Type D Assembly can be used with various vent pipe diameters. This versatility is based on using transition pieces or adapters from the fan outlet to the vent pipe diameter. It is suggested that whenever there is a change in size that a smooth transition piece be used. Refer to Fig. 4.

The Type D Assembly operates with a positive vent static pressure and with a vent gas temperature that avoids excessive condensate production in the vent, and as such it is listed as a CATEGORY III appliance.



**Fig. 3: Minimum Clearances from Vent/Air Inlet Terminations – Indoor and Outdoor Installations**

		<b>U.S. Installations<sup>1</sup></b>	<b>Canadian Installations<sup>2</sup></b>
A	Clearance above grade, veranda, porch, deck, or balcony	1 ft (30 cm)	1 ft (30 cm)
B	Clearance to window or door that may be opened	4 ft (1.2m) below or to side of opening; 1 foot (30 cm) above opening	3 ft (91 cm)
C	Clearance to permanently closed window	*	*
D	Vertical clearance to ventilated soffit located above the terminal within a horizontal distance of 2 ft (61cm) from the centerline of the terminal	5 ft (1.5m)	*
E	Clearance to unventilated soffit	*	*
F	Clearance to outside corner	*	*
G	Clearance to inside corner	6 ft (1.83m)	*
H	Clearance to each side of center line extended above meter/regulator assembly	*	3 ft (91 cm) within a height 15 ft above the meter/regulator assembly
I	Clearance to service regulator vent outlet	*	6 ft (1.83m)
J	Clearance to non-mechanical air supply inlet to building or the combustion air inlet to any other appliance	4 ft (1.2m) below or to side of opening; 1 ft (30 cm) above opening	3 ft (91 cm)
K	Clearance to mechanical air supply inlet	3 ft (91 cm) above if within 10 ft (3m) horizontally	6 ft (1.83m)
L	Clearance above paved sidewalk or paved driveway located on public property	7 ft (2.13m)	7 ft (2.13m) t
M	Clearance under veranda, porch, deck or balcony	*	12 in. (30 cm) TT

<sup>1</sup> In accordance with the current ANSI Z223.1/NFPA 54 National Fuel Gas Code

<sup>2</sup> In accordance with the current CAN/CGA-B149 Installation Codes

t Vent terminal shall not terminate directly above sidewalk or paved driveway located between 2 single family dwellings that serves both dwellings

TT Permitted only if veranda, porch, deck, or balcony is fully open on a minimum of two sides beneath the floor and top of terminal and underside of veranda, porch, deck or balcony is greater than 1 ft (30cm)

\* Clearances in accordance with local installation codes and the requirements of the gas supplier

**Table B: Vent/Air Inlet Termination Clearances**

Models 0514–0724

Models 0824–1223

Models 1336–1826

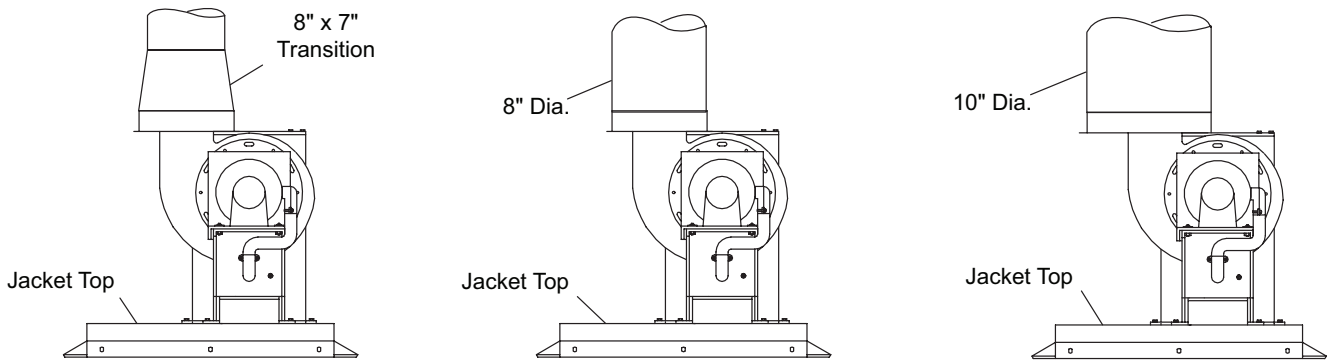

Fig. 4: Draft Assembly with Various Vent Pipe Diameters and Transitions

The exception is when the assembly is connected to a vertical vent of sufficient height to generate a negative draft in the system. In this case, consult sizing guide or the factory.

**WARNING:** No substitutions of flue pipe or vent cap material are allowed. Such substitutions would jeopardize the safety and health of inhabitants.

The Type D Assembly is suitable for through-the-wall venting, and for connection to smaller size vent pipes and breaching other than the standard atmospheric appliance.

### Electrical Wiring

The type D Assembly includes a wire harness which provides quick connections with the respective controls in the heater control box. The harness is of sufficient length to fit the heater for which it is sized.

Reference the wiring diagram supplied with each heater for actual connections.

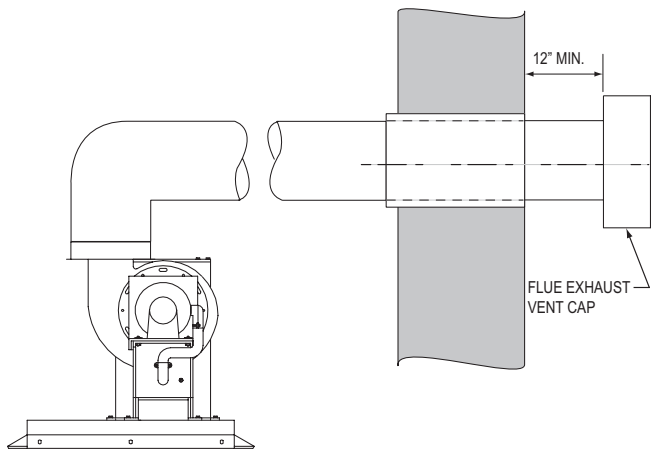

Fig. 5: Draft Assembly Through-The-Wall Venting

### Termination

The flue direct vent cap MUST be mounted on the exterior of the building. The direct vent cap cannot be installed in a well or below grade. The direct vent cap must be installed at least 1 ft above ground level and above normal snow levels. The Raypak-approved stainless steel flue direct vent cap must be used (sales order option D-15).

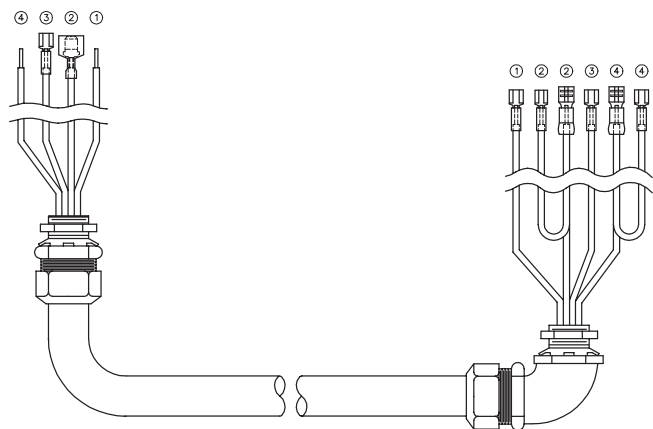
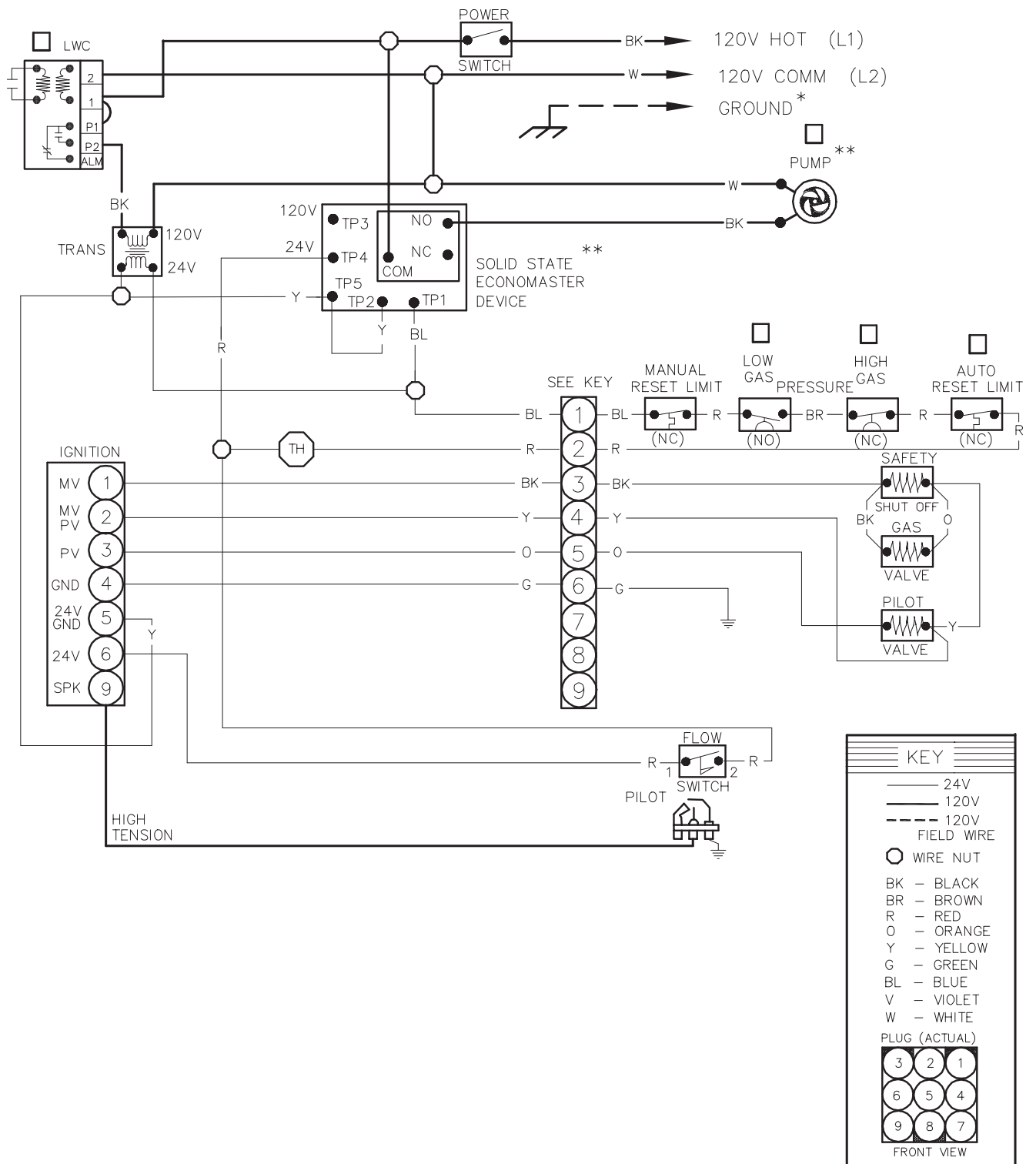

Fig. 6: Draft Assembly Wire Harness



# Wiring Diagram—Existing Heater



# Wiring Diagram—Heater with Installed Power Vent

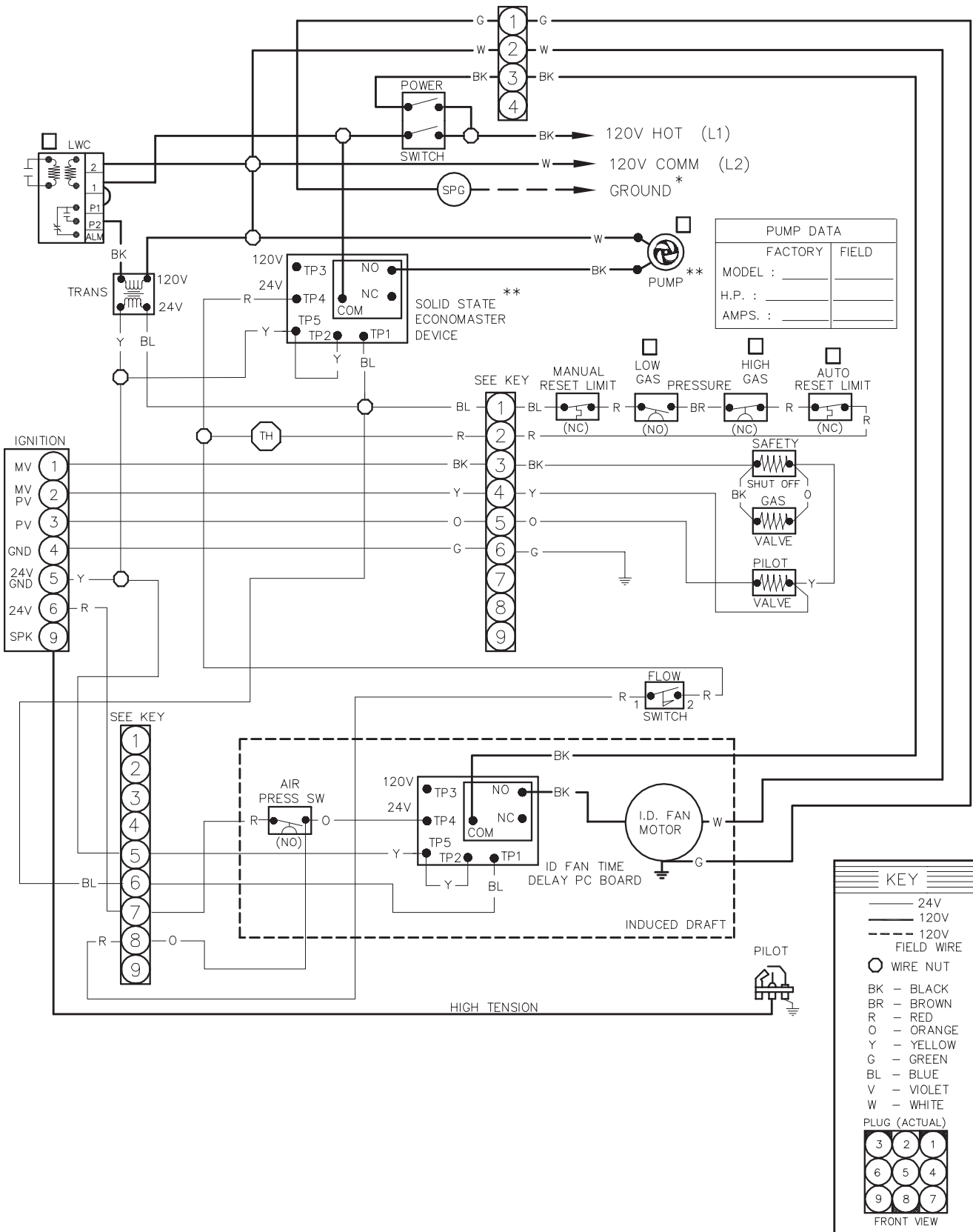

Note: Use the wiring diagram provided with the heater

## Sequence of Operation

On call for heat, the induced draft fan (and heater pump) start. When the draft-proving switch and the flow switch circuits close, the ignition system, consisting of an electronic spark module, pilot gas system and flame sensor, are energized.

When all safety circuits are proven, the automatic main gas valves will open and the heater will operate.

When the operating temperature control circuit is satisfied, the heater will shut down and the fan will operate for a selected post-purge period.

## Start-up Procedures

The water, gas and electrical systems of the heater should be completed and checked as described in the heater installation manual and associated documents.

## Typical S8600 Ignition System

1. Turn on power to the heater with the manual main gas valve and pilot gas valve off. The electric power supply requirements are:
  - 1/3 hp, 120 VAC, 60 Hz, 1 Ph, 5.8 amp fan motor for models 0514 through 1336.
  - 1 hp, 120 VAC, 60 Hz, 1 Ph, 12.6 amp fan motor for models 1414 through 1826.
  - 1/2 hp, 120 VAC, 60 Hz, 1 Ph, 7.2 amp fan motor for models 2100 and 2500.
  - 3/4 hp, 120 VAC, 60 Hz, 1 Ph 10.7 amp fan motor for models 3001 to 4001.
2. Check power connections.
3. Close heater power switch.
4. Set operating control to call for heat.
  - a. Fan motor starts and draft proving switch closes.
  - b. Heater pump starts and flow switch closes.
  - c. Ignition module is energized.
  - d. Check for spark at gas pilot.
5. Turn operating control to end call for heat.
6. Wait a minimum of 60 seconds.
7. Open pilot gas valve.
  - a. Repeat step 4 above.
8. After pilot gas is proven and main safety shut-off valve is energized, slowly open manual main gas shut-off valves and the main burners will ignite.
9. Heater will operate until call for heat is satisfied.
10. Check draft at base of plenum.
  - a. Draft should be  $-0.005$  to  $-0.01$  in. WC at full fire.
  - b. Adjust barometric draft control until this reading is obtained.
11. Restart heater and visually check all components for proper operation.
12. Check all vent connections and joints for leakage. Correct if found.

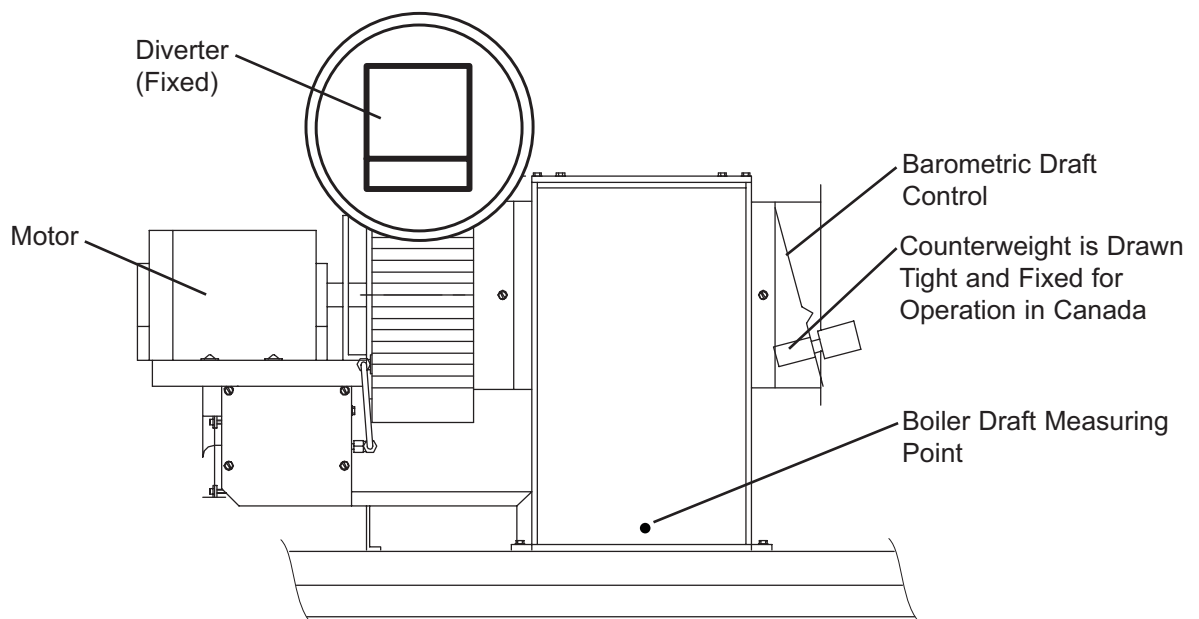

Fig. 7: Induced Draft Vent Terminal, Typical Models 0514–1826

13. To restart heater after a failure, follow the procedures outlined above and other subsequent or related sections outlined in the heater manual.

**NOTE:** Verify shaft rotation is CW when viewed from motor end.

**Emergency Shutdown**—Shut off all power and gas, call gas utility.

## Controls

### Blower Motor Contactor & Purge Relay

The solid state control starts the blower motor and keeps it running for up to one minute after the call for heat is satisfied. This post-purge period clears the combustion area of any residual gas buildup.

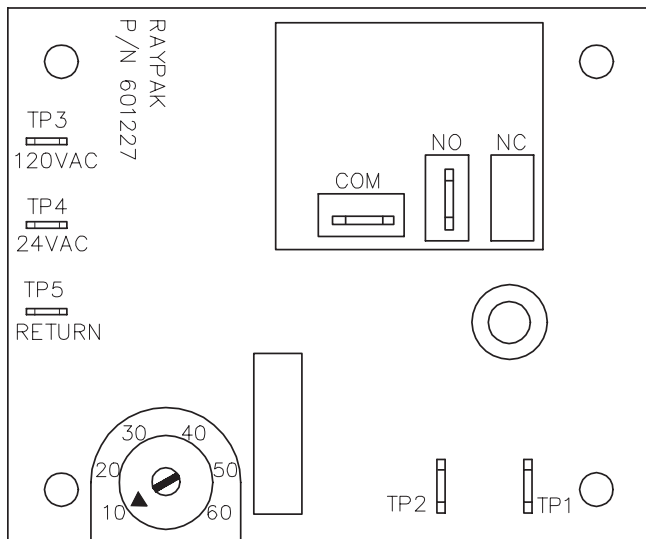

Fig. 8: Solid State Control

### Draft-Proving Switch

The draft-proving switch ensures that the blower is operating. The switch is in the limit circuit and does not allow the ignition module to operate unless it is closed.

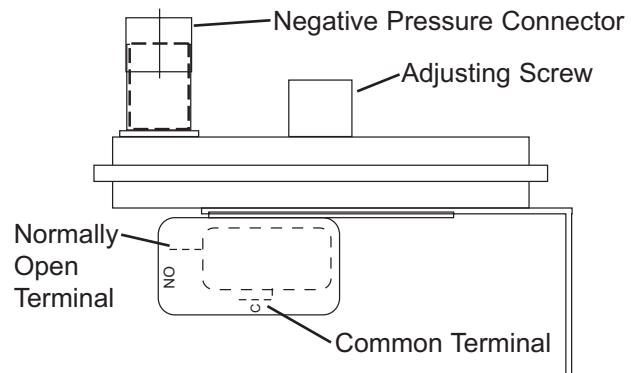

Fig. 9: Draft Proving Switch

## Positions of Discharge

### Models 0514–1826 Only

#### A. Rotate Blower Housing 90° CW or CCW

1. Disconnect pressure tube from blower housing.
2. Remove (6) screws that mount motor to blower housing.
3. Remove (2) rear screws that mount motor to support bracket.
4. Slide out motor.
5. Remove (2) screws that mount blower housing to plenum collar.
6. Rotate blower housing 90° CW or CCW.
7. Reverse above procedure to re-assemble.

#### POSITION 1

STANDARD POSITION AS SHIPPED FROM FACTORY

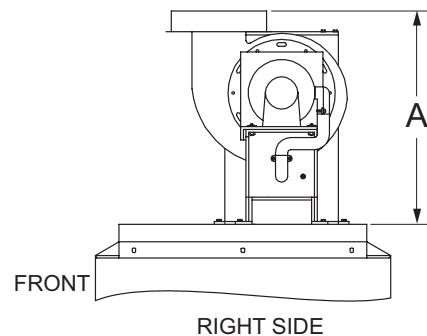
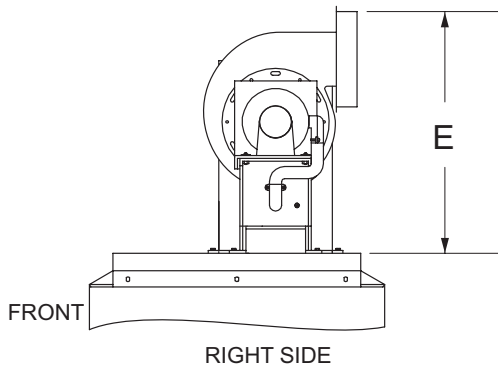

Fig. 10: Blower Assembly Position 1

**POSITION 2**  
 ROTATE BLOWER HOUSING  
 90° CW FROM POSITION 1



**Fig. 11: Blower Assembly Position 2**

**POSITION 4**  
 ROTATE PLENUM/BLOWER ASSY  
 FROM POSITION 2 SO MOTOR  
 IS TOWARD FRONT SIDE OF BOILER

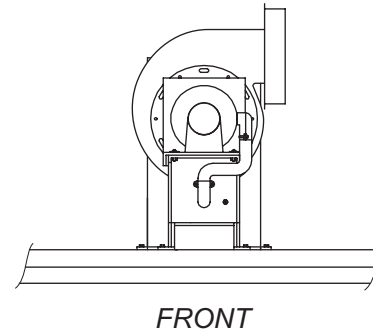

**Fig. 13: Blower Assembly Position 4**

**POSITION 3**  
 ROTATE BLOWER HOUSING  
 90° CCW FROM POSITION 1

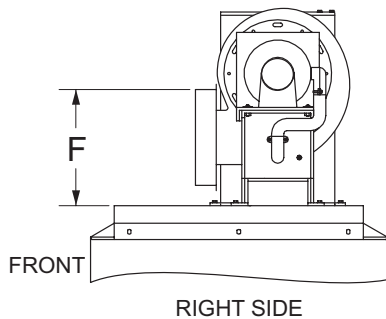

**Fig. 12: Blower Assembly Position 3**

**POSITION 5**  
 ROTATE PLENUM/BLOWER ASSY  
 FROM POSITION 3 SO MOTOR  
 IS TOWARD FRONT SIDE OF BOILER

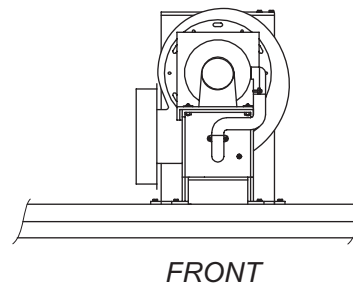

**Fig. 14: Blower Assembly Position 5**

**B. Rotate Plenum/Blower Assembly**

1. Remove (8) screws that mount plenum/blower assembly to jacket top.
2. Rotate plenum/blower assembly from position 2 or 3 so motor is toward front side of unit.
3. Reverse step (1) to re-assemble.

**NOTE:** Vent terminal should be installed with motor toward either the right side or front side of the heater.

Model No.	Without Pump	With Pump
0514-1336	Less than 10 amps @ 120 VAC	Less than 16 amps @ 120 VAC
1468-1826	Less than 18 amps @ 120 VAC	Less than 24 amps @ 120 VAC

**Table C: Electrical Ratings—Models 0514-1826**

## Dimensions—Models 0514–1826

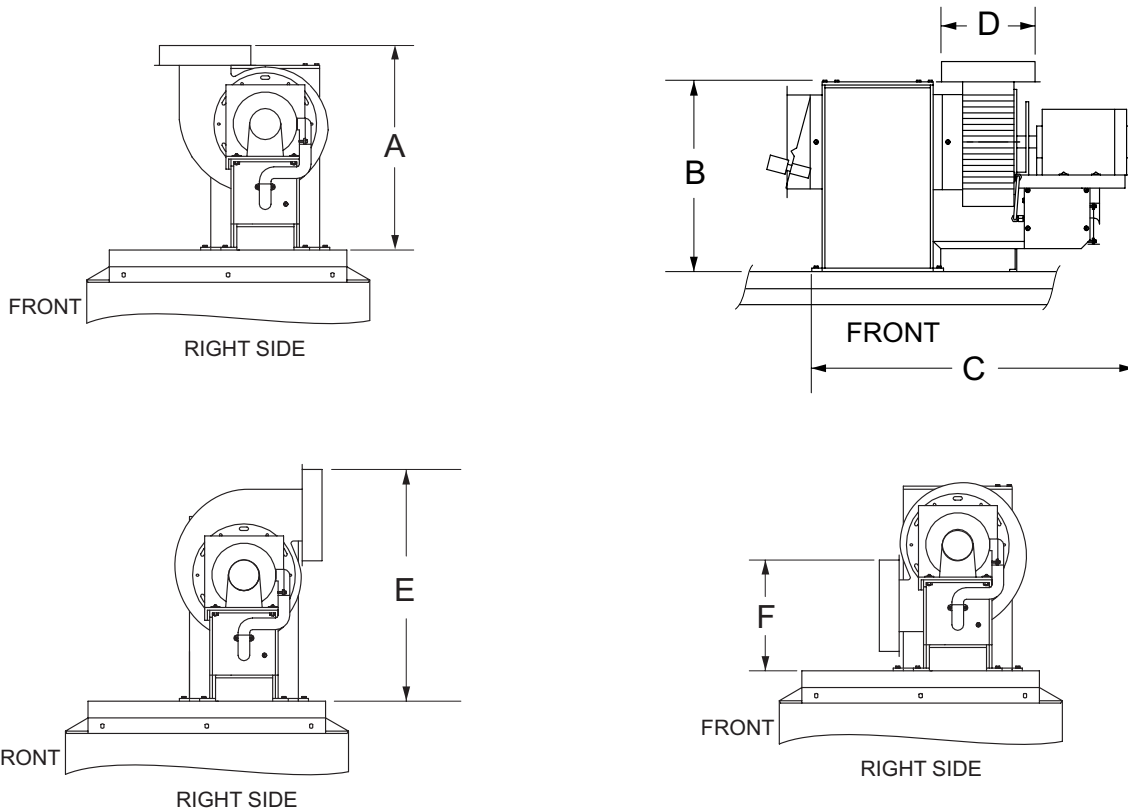

Model No.	MBTUH	Vertical Height (ft)	Max. Horizontal (ft)**	A (in.)	B (in.)	C (in.)	D (in.)	E (in.)	F (in.)
0514	512	20	40	17.88	15.88	20	8*	20.25	9.75
0624	627	20	22	17.88	15.88	20	8*	20.25	9.75
0724	726	20	13	17.88	15.88	20	8*	20.25	9.75
0824	825	20	22	17.88	15.88	20	8	20.25	9.75
0962	962	20	12	19.44	15.88	20	8	21.81	11.31
1125	1125	20	5	19.44	15.88	20	8	21.81	11.31
1223	1223	20	4	19.44	15.88	20	8	21.81	11.31
1336	1336	20	21	21	18.62	42	10	23.5	12.5
1468	1468	20	15	21	18.62	42	10	23.5	12.5
1631	1631	20	10	21	18.62	42	10	23.5	12.5
1826	1826	20	5	21	18.62	42	10	23.5	12.5

\* May be reduced to 7" by using 8" x 7" transition. Transition is not provided by Raypak.

\*\*Subtract 10 ft per elbow, if applicable.

Table D: Dimensions, Models 0514–1826

## Dimensions—Models 2100–4001

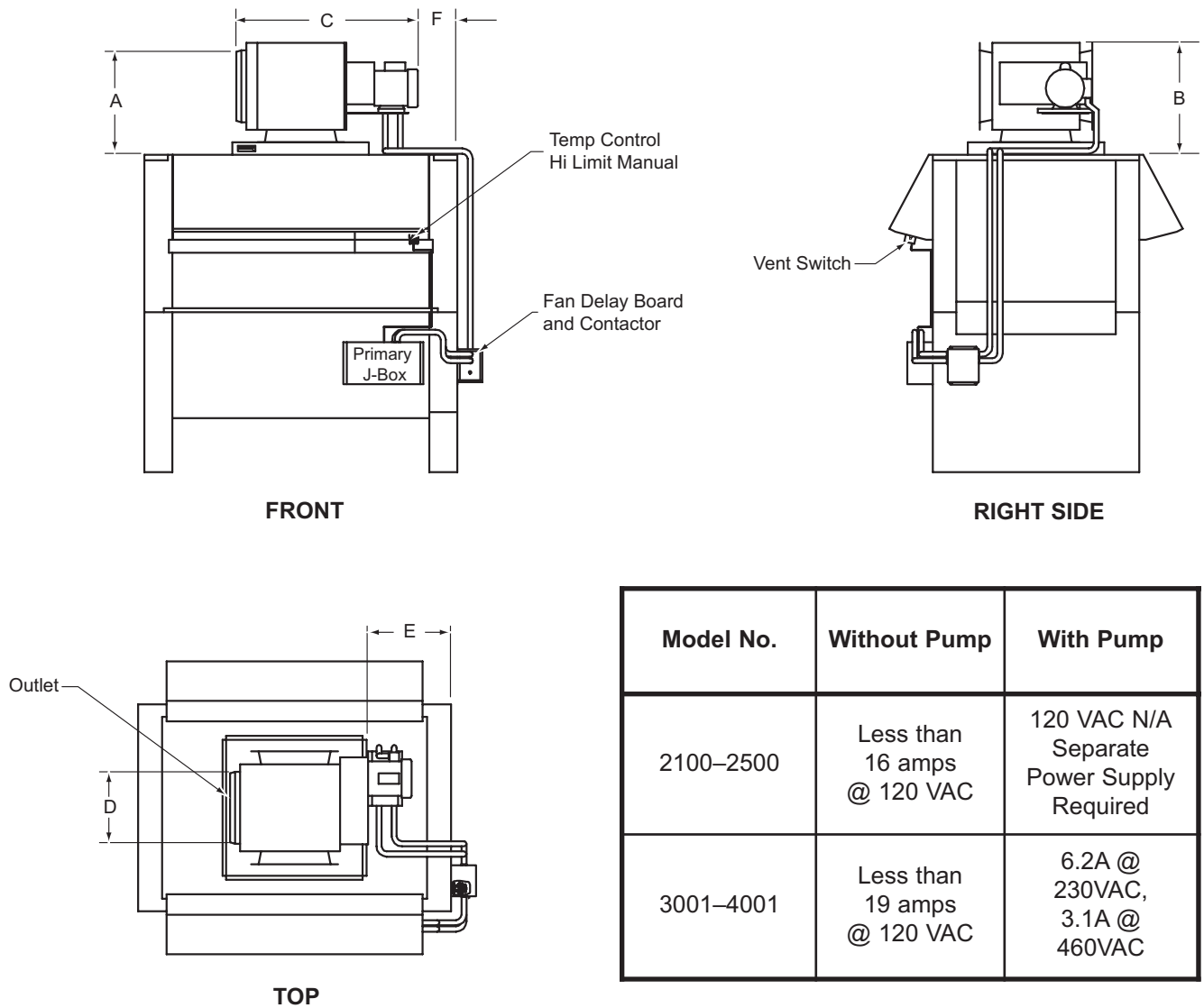

Model No.	Without Pump	With Pump
2100–2500	Less than 16 amps @ 120 VAC	120 VAC N/A Separate Power Supply Required
3001–4001	Less than 19 amps @ 120 VAC	6.2A @ 230VAC, 3.1A @ 460VAC

Table E: Electrical Ratings—Models 2100–4001

Model No.	MBTUH	Vertical Height (ft)	Max. Horizontal (ft)*	A (in.)	B (in.)	C (in.)	D (in.)	E (in.)	F (in.)
2100	2100	20	60	16.88	22.38	33.5	14	17.25	7.68
2500	2499	20	60	16.88	22.38	33.5	14	21.75	12.18
3001	3000	20	60	24.25	27.38	44.75	16	23.62	10.12
3500	3500	20	60	24.25	27.38	44.75	16	29.25	15.75
4001	4000	20	60	24.25	27.38	44.75	16	34.88	21.38

\*Subtract 10 ft per elbow, if applicable.

Table F: Dimensions, Models 2100–4001



**[www.raypak.com](http://www.raypak.com)**

Raypak, Inc., 2151 Eastman Avenue, Oxnard, CA 93030 (805) 278-5300 Fax (805) 278-5468  
Litho in U.S.A.